

POLY BONNET REPLACEMENT INSTRUCTIONS (DISASSEMBLY)

A 1-5/16" or adjustable wrench is required to remove the Zinc bonnet

PARTS SHIPPED IN THIS KIT: ASSEMBLE AS SHOWN

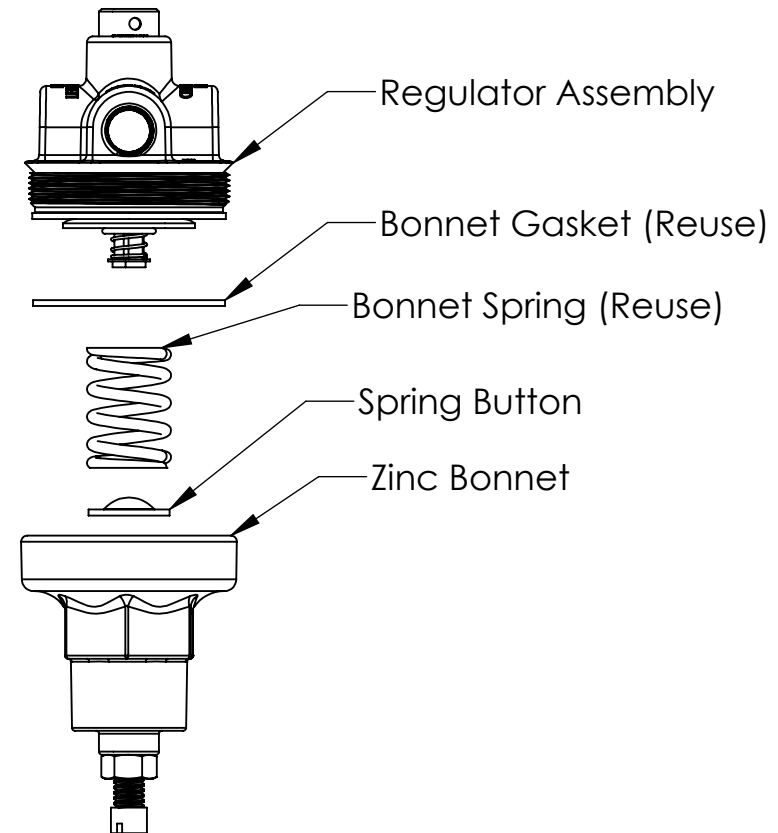
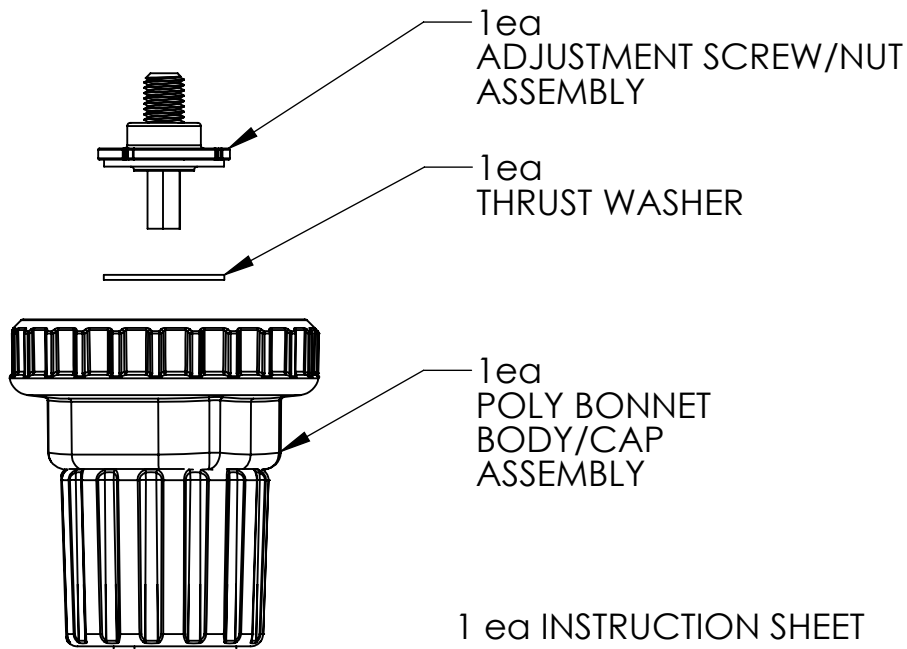

STEP 1. Unscrew (counter clockwise) Zinc bonnet off Regulator body.

STEP 2. Remove Zinc bonnet and Spring button from assembly. Bonnet spring and bonnet gasket will be reused.

PART NO. 42-0002-00
REV. A DATED: 12/08/09

POLY BONNET REPLACEMENT INSTRUCTIONS (ASSEMBLY)

A 1-5/8" or adjustable wrench is required to tighten the Poly bonnet

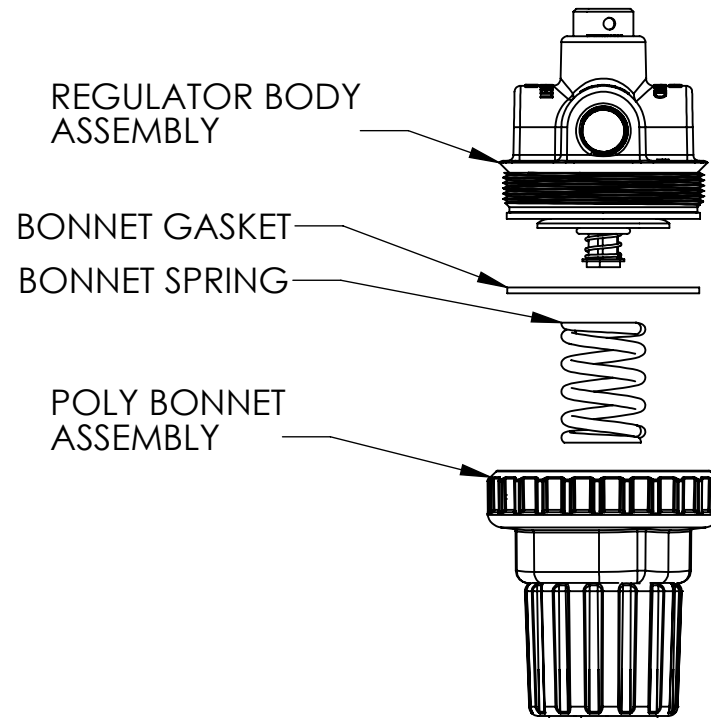
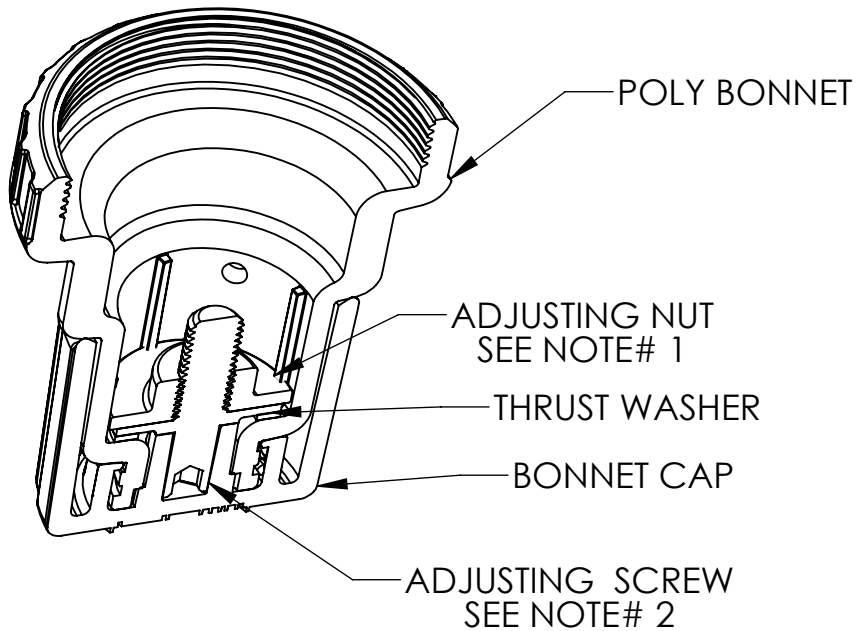

NOTES:

1. Insure adjustment nut grooves are aligned with bonnets ribs.
2. Adjusting screw head should be seated. Pull bonnet cap to adjust and then turn until screw/nut assembly drops down into cap.

STEP 3. Once you are sure the adjustment screw/nut is seated. Drop the Bonnet spring and bonnet gasket into the bonnet assembly.

STEP 4. Screw the bonnet assembly onto the Regulator body and tighten with 1-5/8" or adjustable wrench.