

Casa2G and Premio2G

Residential Modular Refractory Ovens

Forno Bravo, LLC

Installation and Operating Manual

Casa2G and Premio2G Residential Modular Refractory Ovens, including:
Casa2G 80, Casa2G 90, Casa2G 100, Casa2G 110
Premio2G 100, Premio2G 110, Premio2G 120

A MAJOR CAUSE OF OVEN-RELATED FIRE IS FAILURE TO MAINTAIN REQUIRED CLEARANCES (AIR SPACES) TO COMBUSTIBLE MATERIALS. IT IS OF UTMOST IMPORTANCE THAT THIS OVEN BE INSTALLED ONLY IN ACCORDANCE WITH THESE INSTRUCTIONS.

IF THIS OVEN IS NOT PROPERLY INSTALLED, A FIRE MAY RESULT. TO REDUCE THE RISK OF FIRE, FOLLOW THESE INSTALLATION INSTRUCTIONS.

Contact the factory, factory representative or a local service company to perform maintenance and repairs.

Forno Bravo, LLC
13525 Blackie Road
Castroville, CA 95012
(800) 407-5119
info@fornobravo.com
www.fornobravo.com

UL 737, UL2162, NSF-4, ANSI-Z21.58-2018, CSA 1.6-2018 Listed



Casa2G and Premio2G

Residential Modular Refractory Ovens

WARNING. Improper installation, adjustment, alteration, service, or maintenance can result in property damage, injury, or death. Please read this entire manual and the installation, operating, and maintenance instructions thoroughly before installing or servicing this equipment.

DANGER — IF YOU SMELL GAS:

- 1. Shut off gas to the oven.**
- 2. Extinguish any open flame.**
- 3. Open door.**
- 4. If odor continues, keep away from the oven and immediately call your gas supplier or your fire department.**

In a prominent location, please post a statement outlining this procedure (or an alternate procedure to follow in the event that you smell gas, available from your local gas supplier.)

WARNING — FOR YOUR SAFETY:

- 1. Do not store or use gasoline or other flammable vapors or liquids in the vicinity of this or any other appliance.**
- 2. An LP cylinder not connected for use shall not be stored in the vicinity of this or any other appliance.**
- 3. Always keep the area under and around this appliance free and clear of any and all combustible materials.**

Installation must conform to local codes. Contact your local building or fire officials about codes, restrictions, and installation inspection in your area. In the absence of local codes, installation must conform to the *National Fuel Gas Code*, ANSI Z223.1/NFPA 54, *Natural Gas and Propane Installation Code*, CSA B149.1, or *Propane Storage and Handling Code*, B149.2, as applicable. It is recommended that this oven be installed, maintained and serviced by authorized professionals.

Always disconnect the power supply to the oven before servicing or cleaning.

IMPORTANT: Always use safety equipment provided with your oven such as gas regulator and gas leak detector. Do not change gas orifices without consulting manufacturing representatives prior to making change. Incorrect orifice or gas pressure can result in carbon monoxide exceeding safety levels.

IMPORTANT: Do not change fuel types between natural gas and propane without consulting manufacturer, manufacturer's representative or local service representative. Natural gas and propane require different orifices and failure to use correct fittings can present risk of fire or carbon monoxide poisoning.

WARNING: Always shut off natural gas or propane source and purge line when not in use or before performing maintenance on gas module. When operating oven as wood only, be sure to turn off natural gas or propane supply line and set to off position on control panel.

IMPORTANT: When using gas burner after sitting, test for leaks before firing oven. If pilot light goes out, use gas leak detector to check for gas buildup before reigniting.



Casa2G and Premio2G

Residential Modular Refractory Ovens

WARNING

READ ALL INSTRUCTIONS BEFORE INSTALLING AND USING THE APPLIANCE. FAILURE TO FOLLOW INSTRUCTIONS MAY RESULT IN PROPERTY DAMAGE, BODILY INJURY, OR EVEN DEATH.

When this oven is not properly installed, a fire may result. To reduce the risk of fire, follow the installation instructions. It is essential to use only building and insulation materials designed for the purpose.

Use proper safety equipment when installing this oven, including gloves and professional breathing masks.

Contact your local building or fire officials for clarification on any restrictions on installation of this oven in your area, or need for inspection of the oven installation.

HOT WHILE IN OPERATION. KEEP CHILDREN, CLOTHING AND FURNITURE AWAY. CONTACT MAY CAUSE SKIN BURNS.

DO NOT BURN GARBAGE OR FLAMMABLE FLUIDS.

DO NOT CONNECT THIS UNIT TO A CHIMNEY FLUE SERVING ANOTHER APPLIANCE.

Keep children and pets away from hot oven.

Use firewood for burning only. **DO NOT** use charcoal, pressure treated lumber, chipped wood products, sappy wood such as pine, laminated wood or any material other than dry medium or hard firewood.

DO NOT USE liquid fuel (firelighter fluid, gasoline, lantern oil, kerosene or similar liquids) to start or maintain a fire.

BEWARE of very high temperatures in the oven and use long oven gloves and mitts to handle pots and tools. **DO NOT** put unprotected hands or arms inside oven while it is lit.

Dispose of ashes using a metal shovel and place in a metal bin with a tightly fitting lid. The container should be stored on a non-combustible surface, away from all combustible materials. Ensure ashes are completely cold before disposing of them appropriately.

BEWARE of flying sparks from mouth of oven. Ensure that no combustible materials are within range of oven at any time.

DO NOT close the oven door fully while a fire is in the oven. Closing the door fully will cut off oxygen to the fire, causing the fire to erupt suddenly when the door is removed. Always keep door tilted to allow air to circulate in the oven.

DO NOT use water to dampen or extinguish fire in the oven.

DO NOT pack required air spaces with insulation or other materials.

When the curing of the refractories is not done as part of the manufacturing process, the manufacturer's recommended curing process shall be specified. Follow the instructions for curing the oven. Failure to follow the curing schedule can cause damage to the oven, and void the oven warranty.

SAVE THESE INSTRUCTIONS



Casa2G and Premio2G

Residential Modular Refractory Ovens

Table of Contents

Contained in the Crate	5
At-a-Glance Casa2G	6
At-a-Glance Premio2G.....	8
Oven Clearances.....	10
Installation Elevations	11
Stand Dimensions	12
Corner Installation	13
Quick Start Guide	14
1. Foundation	17
2. The Oven Stand	18
3. The Insulating Hearth.....	20
4. Set the Cooking Floor.....	21
5. Dome Assembly	22
6. Chimney Installation	23
7. Insulate the Oven Dome.....	27
8. Enclosure Design Styles	27
9. Igloo Enclosure.....	27
10. Walled Enclosures	28
11. Curing Your Oven.....	29
12. Wood Firing and Operation.....	30
13. Maintenance and Cleaning	30
Appendix 1. Installation Tools List.....	32
Appendix 2. Material List.....	33
Appendix 3. Cucina Stand Assembly	34
Appendix 4. Instructions for Assembling the Gas Burner	35
Appendix 5: Oven Dimensions	52
Appendix 6: Warranty.....	144

Casa2G and Premio2G

Residential Modular Refractory Ovens

Contained in the Crate

Oven dome with integral vent;
Firebrick tile oven floor and landing;
Steel door with thermometer;
Ceramic blanket dome insulating;
Ceramic board floor insulation;
High temp, waterproof mortar;
24" stainless steel, single wall chimney with rain cap for outdoor use only.

Contained in the Crate (gas version)

Remote probe thermometer and gas leak detector for gas units only.
Burner, controller and regulator.

Options

Decorative brick arch
Extra 24" single wall chimney pipe sections
DuraTechUL103 double wall chimney system
Infrared thermometer
Remote probe thermometer
Tuscan grill
Pizza peels
Oven brushes, rakes and shovels



Casa2G 80/90

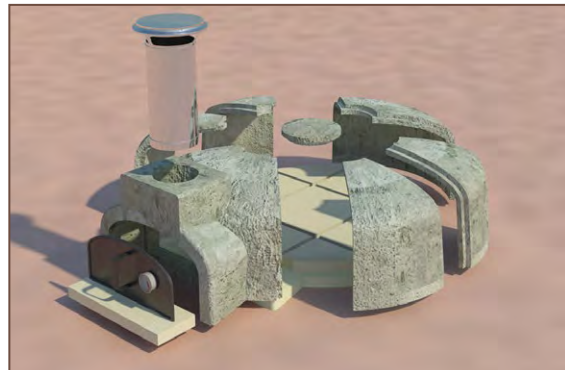

Casa2G 110



Premio2G 110



Casa2G and Premio2G

Residential Modular Refractory Ovens

At-a-Glance Casa2G

	Casa2G80	Casa2G90	Casa2G100	Casa2G110
Cooking Floor	32"W x 40"D	36"W x 44"D	40"W x 48"D	44"W x 52"D
External Dimensions	36"W x 42"D x 19"H	40"W x 46"D x 19"H	44"W x 50"D x 20"H	48"W x 54"D x 20"H
Oven Opening	17"W x 10"H	17"W x 10"H	20"W x 10.5"H	20"W x 10.5"H
Vent Landing	20.5"W x 8"D	20.5"W x 8"D	23.5"W x 8"D	23.5"W x 8"D
Dome Height	15"	15"	16"	16"
Monoblock Oven Opening with Integral Vent	✓	✓	✓	✓
Sealing Door Jamb	✓	✓	✓	✓
Vent Opening Diameter	6"	6"	8"	8"
Chimney Type	SS Stove Pipe, UL103HT Chimney Pipe (upgrade)	SS Stove Pipe, UL103HT Chimney Pipe (upgrade)	SS Stove Pipe, UL103HT Chimney Pipe (upgrade)	SS Stove Pipe, UL103HT Chimney Pipe (upgrade)
Commercial Grade, Kiln-Fired Cooking Floor	✓	✓	✓	✓
Ceramic Insulation Blanket	3 x 1"	3 x 1"	3 x 1"	3 x 1"
Floor Ceramic Insulation Board	1 x 2"	1 x 2"	1 x 2"	1 x 2"
High Temp, Waterproof Mortar	25 lb.	25 lb.	50 lb.	50 lb.
24" Single Wall Stainless Steel Chimney with Cap	6" diameter	6" diameter	8" diameter	8" diameter
Steel Door with Thermometer	✓	✓	✓	✓
Dome Pieces	3	3	5	7
Pizzas at a Time	2	3	5	7
Weight (without crate)	750 lb.	825 lb.	1025 lb.	1150 lb.

*All measurements in U.S.

Casa2G and Premio2G

Residential Modular Refractory Ovens

At-a-Glance Casa2G Gas Version

	Casa2G80	Casa2G90	Casa2G100	Casa2G110
BTU	Natural Gas-38,000, Liquid Propane-51,000	Natural Gas-38,000, Liquid Propane-51,000	Natural Gas-38,000, Liquid Propane-51,000	Natural Gas-38,000, Liquid Propane-51,000
Orifice Size	Natural Gas: 2.75 Liquid Propane: 2.25	Natural Gas: 2.75 Liquid Propane: 2.25	Natural Gas: 2.75 Liquid Propane: 2.25	Natural Gas: 2.75 Liquid Propane: 2.25
WC Levels with burner kit	Natural Gas 5-10 WC, Liquid Propane 10-12 WC	Natural Gas 5-10 WC, Liquid Propane 10-12 WC	Natural Gas 5-10 WC, Liquid Propane 10-12 WC	Natural Gas 5-10 WC, Liquid Propane 10-12 WC
Cooking Floor	32"W x 40"D	36"W x 44"D	40"W x 48"D	44"W x 52"D
External Dimensions	36"W x 42"D x 19"H	40"W x 46"D x 19"H	44"W x 50"D x 20"H	48"W x 54"D x 20"H
Oven Opening	17"W x 10"H	17"W x 10"H	20"W x 10.5"H	20"W x 10.5"H
Vent Landing	20.5"W x 8"D	20.5"W x 8"D	23.5"W x 8"D	23.5"W x 8"D
Dome Height	15"	15"	16"	16"
Monoblock Oven Opening with Integral Vent	✓	✓	✓	✓
Sealing Door Jamb	✓	✓	✓	✓
Vent Opening Diameter	6"	6"	8"	8"
Chimney Type	SS Stove Pipe, UL103HT Chimney Pipe (upgrade)	SS Stove Pipe, UL103HT Chimney Pipe (upgrade)	SS Stove Pipe, UL103HT Chimney Pipe (upgrade)	SS Stove Pipe, UL103HT Chimney Pipe (upgrade)
Commercial Grade, Kiln-Fired Cooking Floor	✓	✓	✓	✓
Ceramic Insulation Blanket	3 x 1"	3 x 1"	3 x 1"	3 x 1"
Floor Ceramic Board Insulation	1 x 2"	1 x 2"	1 x 2"	1 x 2"
High Temp, Waterproof Mortar	25 lb.	25 lb.	50 lb.	50 lb.
24" Single Wall Stainless Steel Chimney with Cap	6" diameter	6" diameter	8" diameter	8" diameter
Steel Door with Thermometer	✓	✓	✓	✓
Dome Pieces	3	3	5	7
Pizzas at a Time	2	3	5	7
Weight (without crate)	750 lb.	825 lb.	1025 lb.	1150 lb.

*All measurements in U.S.



Casa2G and Premio2G

Residential Modular Refractory Ovens

At-a-Glance Premio2G

	Premio2G 100	Premio2G 110	Premio 2G 120
Cooking Floor	40"W x 48"D	44"W x 52"D	48"W x 56"D
External Dimensions	46"W x 51"D x 21"H	50"W x 55"D x 21"H	54"W x 59"D x 21"H
Oven Opening	20"W x 10.5"H	20"W x 10.5"H	20"W x 10.5"H
Vent Landing	23.5"W x 8"D	23.5"W x 8"D	23.5"W x 8"D
Dome Height	16"	16"	16"
Monoblock Oven Opening with Integral Vent	✓	✓	✓
Sealing Door Jamb	✓	✓	✓
Vent Opening Diameter	8"	8"	8"
Chimney Type	SS Stove Pipe, UL103HT Chimney Pipe (upgrade)	SS Stove Pipe, UL103HT Chimney Pipe (upgrade)	SS Stove Pipe, UL103HT Chimney Pipe (upgrade)
Commercial Grade, Kiln-Fired Cooking Floor	✓	✓	✓
Ceramic Insulation Blanket	4 x 1"	4 x 1"	4 x 1"
Floor Ceramic Insulation Board	1 x 3"	1 x 3"	1 x 3"
High Temp, Waterproof Mortar	50 lb.	50 lb.	50 lb.
24" Single Wall Stainless Steel Chimney with Cap	✓	✓	✓
Steel Door with Thermometer	✓	✓	✓
Dome Pieces	5	7	7
Pizzas at a Time	5	7	9
Weight (without crate)	1300 lb.	1450 lb.	1600 lb.

*All measurements in U.S.

Casa2G and Premio2G

Residential Modular Refractory Ovens

At-a-Glance Premio2G Gas Version

	Premio2G 100	Premio2G 110	Premio 2G 120
BTUs	Natural Gas-38,000, Liquid Propane-51,000	Natural Gas-38,000, Liquid Propane-51,000	Natural Gas-38,000, Liquid Propane-51,000
Orifice Sizes	Natural Gas: 2.75 Liquid Propane: 2.25	Natural Gas: 2.75 Liquid Propane: 2.25	Natural Gas: 2.75 Liquid Propane: 2.25
WC Levels with burner kit	Natural Gas 5-10 WC, Liquid Propane 10-12 WC	Natural Gas 5-10 WC, Liquid Propane 10-12 WC	Natural Gas 5-10 WC, Liquid Propane 10-12 WC
Cooking Floor	40"W x 48"D	44"W x 52"D	48"W x 56"D
External Dimensions	46"W x 51"D x 21"H	50"W x 55"D x 21"H	54"W x 59"D x 21"H
Oven Opening	20"W x 10.5"H	20"W x 10.5"H	20"W x 10.5"H
Vent Landing	23.5"W x 8"D	23.5"W x 8"D	23.5"W x 8"D
Dome Height	16"	16"	16"
Monoblock Oven Opening with Integral Vent	✓	✓	✓
Sealing Door Jamb	✓	✓	✓
Vent Opening Diameter	8"	8"	8"
Chimney Type	SS Stove Pipe, UL103HT Chimney Pipe (upgrade)	SS Stove Pipe, UL103HT Chimney Pipe (upgrade)	SS Stove Pipe, UL103HT Chimney Pipe (upgrade)
Commercial Grade, Kiln-Fired Cooking Floor	✓	✓	✓
Ceramic Insulation Blanket	4 x 1"	4 x 1"	4 x 1"
Floor Ceramic Insulation Board	1 x 3"	1 x 3"	1 x 3"
High Temp, Waterproof Mortar	50 lb.	50 lb.	50 lb.
24" Single Wall Stainless Steel Chimney with Cap	✓	✓	✓
Steel Door with Thermometer	✓	✓	✓
Dome Pieces	5	7	7
Pizzas at a Time	5	7	9
Weight (without crate)	1300 lb.	1450 lb.	1600 lb.

*All measurements in U.S.

Casa2G and Premio2G

Residential Modular Refractory Ovens

Oven Clearances

It is essential to maintain clearance space between the oven components and any combustible material, such as walls and ceilings. Failure to maintain these clearances can result in fire.

Combustible Wall Clearance

The oven must have a minimum 1" (25 mm) clearance to combustibles from all sides, and 14" (35 cm) clearance to combustibles from the top.

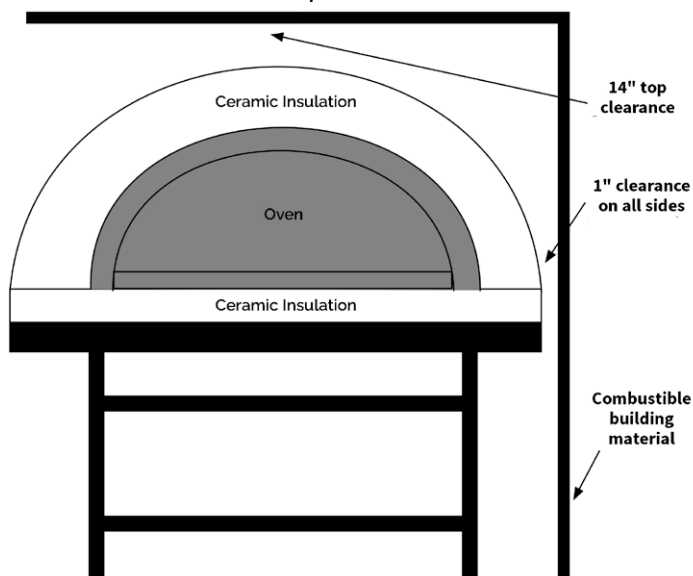

If building materials will contact the oven, they must be completely noncombustible. Please note that standard drywall (or sheet rock) is considered a combustible.

The area directly above the doorway and 6" (15 cm) to each side of the doorway must be covered with non-combustible material.

Non-combustible construction may contact the oven and must then maintain 1" (25 mm) clearance to combustibles.

If the space between the legs of the stand is used for wood storage, it is recommended that it be a covered container

or box to prevent the possibility of sparks or embers from making contact with the stored wood. An 8-1/2" (eight and one-half inch) (21 cm) air space clearance is required between the bottom of the oven and any wood storage container.

Floor Hearth Extension

The minimum floor hearth extension areas from the oven door opening to combustible floors are as follows:

- 30" (76 cm) to each side of the door opening
- 36" (91 cm) in front of the door opening



Casa2G and Premio2G

Residential Modular Refractory Ovens

Installation Elevations

Top Elevation

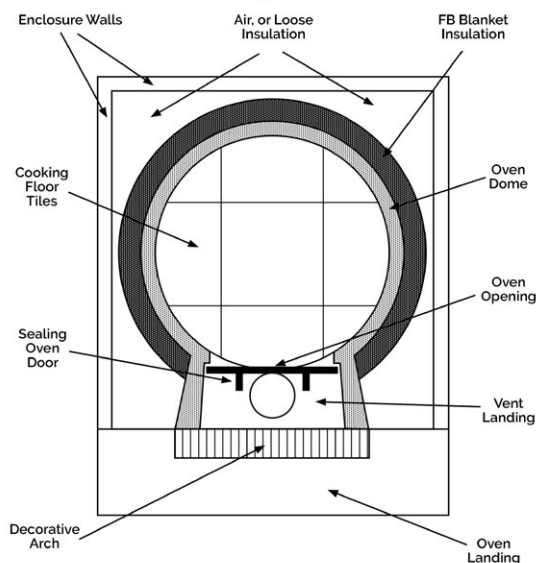

Front Elevation: Igloo

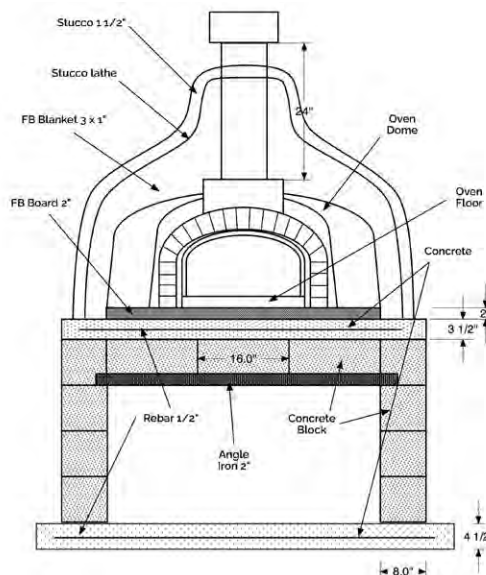

Front Elevation: Block Stand and Insulation

This example uses standard concrete blocks (CMU).

Cross Section: Igloo

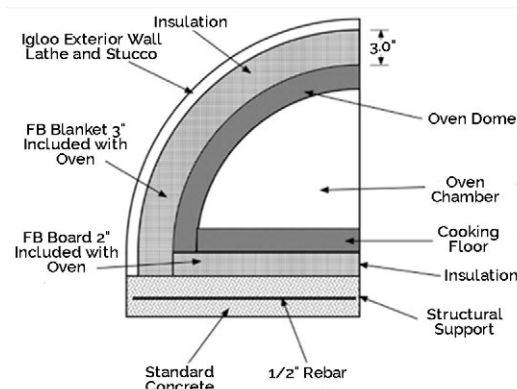
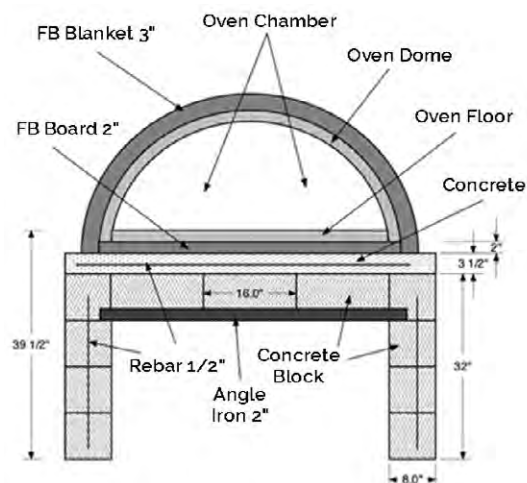

Casa2G and Premio2G

Residential Modular Refractory Ovens

Stand Dimensions

	Oven Exterior	Dome Insulation	Floor Insulation	Hearth Width	Hearth Depth
Casa2G 80	36"W x 42"D (91.44 cm x 108.68 cm)	3" (7 cm)	2" (5 cm)	46" (116 cm)	53" (134.62 cm)
Casa2G 90	40"W x 46"D (101.6 cm x 116.84 cm)	3" (7 cm)	2" (5 cm)	50" (127 cm)	57" (144.78 cm)
Casa2G 100	44"W x 50"D (111.76 cm x 127 cm)	3" (7 cm)	2" (5 cm)	54" (137.16 cm)	61" (154.94 cm)
Casa2G 110	48"W x 54"D (121.92 cm x 137.16 cm)	3" (7 cm)	2" (5 cm)	58" (147.32 cm)	65" (165.1 cm)
Premio2G 100	46"W x 51"D (116.84 cm x 129.54 cm)	4" (10 cm)	3" (7 cm)	58" (147.32 cm)	63" (160.02 cm)
Premio2G 110	50"W x 55"D (127 cm x 139.7 cm)	4" (10 cm)	3" (7 cm)	62" (157.48 cm)	67" (170.18 cm)
Premio2G 120	54"W x 59"D (137.16 cm x 149.86 cm)	4" (10 cm)	3" (7 cm)	66" (167.64 cm)	71" (180.34 cm)

The stand dimensions for your specific oven installation are based on the following formula:

Width = Oven exterior width + insulation thickness + enclosure wall thickness.

Depth = Oven exterior depth + rear insulation thickness + rear enclosure wall thickness + landing depth

The sample dimensions above are based on 2" (5 cm) upper walls and a 6" (15 cm) oven landing. Adjust your dimensions according to your specific installation.

Casa2G and Premio2G

Residential Modular Refractory Ovens

Corner Installation:

Casa2G 80 32" (81 cm) (internal)

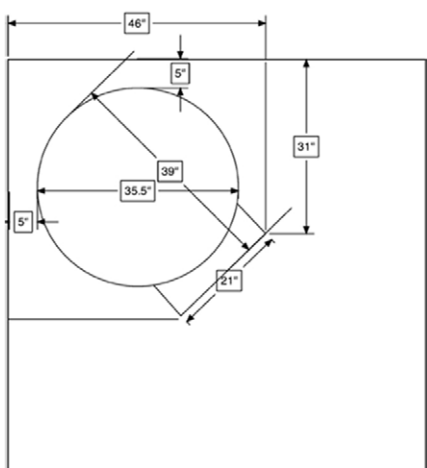

Casa2G 100 40" (101 cm)(internal)

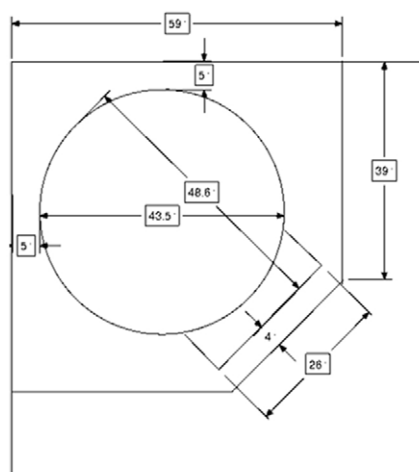

Casa2G 90 36" (91 cm) (internal)

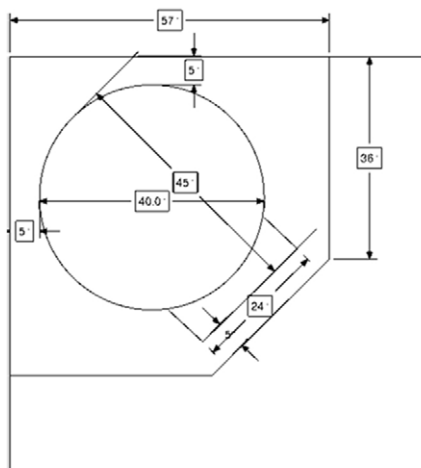

Casa2G 110 44" (111 cm)(internal)

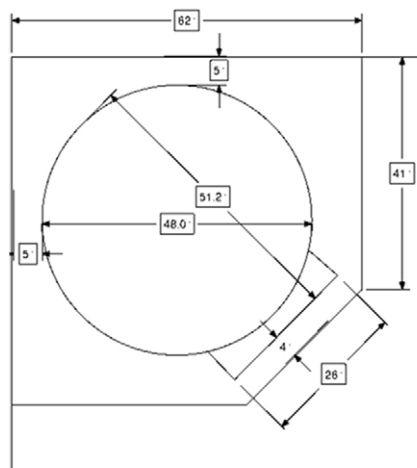

Casa2G and Premio2G

Residential Modular Refractory Ovens

Quick Start Guide

The Quick Start Guide gives you a snapshot overview of the installation process.

Foundation Slab

Frame and pour a standard 3 1/2" (8 cm) rebar reinforced concrete slab.



Concrete Hearth

Frame and pour a 3 1/2" (8 cm) rebar reinforced concrete hearth using Hardibacker as a permanent bottom form.



Oven Stand

Assembled a block stand to the appropriate hearth width.



Gas option: a minimum of 19 3/4" w x 19 3/4" h (50.1 cm w x 50.1 cm h) opening is required for air flow to burner assembly.

Floor Insulation

Cut and assemble the FB Board insulating board to fit under the oven. It can be assembled on wet or dry concrete, and does not require adhesive.



Casa2G and Premio2G

Residential Modular Refractory Ovens

Oven Floor Assembly

Assemble and level the cooking floor on a bed of fine sand.



Oven Dome Assembly

Assemble the oven dome and seal the outside of the oven dome seams with refractory mortar. Do not put mortar inside the joints or between the oven pieces. Seal the bottom of the dome and the oven landing to the insulation board using refractory mortar.



Chimney Assembly

Coat the bottom of the chimney with fireplace caulk and slide the chimney into the round vent opening. Seal the chimney and vent with additional fireplace caulk. For UL103 installation, screw the chimney system anchor place in place using chimney caulk to seal.



For refractory chimney installation, follow the instructions in Chapter 6 of this manual.

Cucina Stand Option

Refer to the Cucina Appendix (p. 35) for assembly.

Casa2G and Premio2G

Residential Modular Refractory Ovens

Oven Insulation

Wrap the oven in three or four layers of 1" (2.5 cm) FB Blanket (depending on the oven model). Overlap the



joints.

Attach the Brick Arch

Attach the optional Brick Arch using standard masons mortar.



Shape the Igloo

Shape the Igloo with wire lathe and cover with a two coat stucco system.



For other enclosure types, refer to Chapter 9 of this manual.



Casa2G and Premio2G

Residential Modular Refractory Ovens

1. Foundation

Overview

Your oven stand and oven chamber are installed on a concrete pad. We recommend a minimum thickness of 5 1/2" (14 cm) for the foundation slab, however your location, soil conditions and local building ordinances will dictate the thickness required.

The slab dimensions listed below are 8" (20 cm) wider than the dimensions of your concrete block stand, providing you with 2" (5 cm) for finish material, and a 2" (5 cm) reveal on either side of the stand. The slab is also 10" (25 cm) deep, allowing for 4" (10 cm) in the back (2" (5 cm) finish and reveal), and 6" (15 cm) in front (the additional space makes a nice edge for your wood storage). The foundation slab will also be used to support forms that you will use during the hearth slab construction. The finished top of the slab should be 2"-3" (5-8 cm) above ground level.

Instructions

First, excavate your foundation. The slab frame for a 5 1/2" (14 cm) foundation is best composed of 2" x 6" (5 x 15 cm) lumber set so the top of the form is 2-3" (5-8 cm) above ground level. The longer form boards should sit inside the shorter boards, and the completed form can be held in place by driving wooden stakes into the ground around the perimeter. Before securing everything permanently, check to make sure the form is located and faces exactly where you want it, and is level and square.

Lay a 3" (9 cm) base of pea gravel (or crushed rock), compact the rock, and cover it with a layer of 6 ml plastic sheeting to stop the slab from wicking water.

Place a sheet of wire mesh inside the foundation frame, and install a two-piece grid using 1/2" (1 cm) rebar (#4) set 4" (10 cm) and 8" (20 cm) inside the foundation frame. Tie the rebar together with tie wire, then set the wire mesh and rebar half way up the

pad (2 3/4" or 7 cm), using either rebar stand-offs or fragments of brick.



1.1. Framed, lined, with wire mesh and rebar.

Mix and pour the concrete, and then level it. Use a 2" x 4" (5 x 10 cm) to screed and level the concrete, then finish to a smoothness that works for you as the bottom of your wood storage area. Allow the slab to cure for a day or two. Keeping it damp will help it cure better and become stronger.



1.2. The finished foundation ready to cure.

Other Considerations

Depending on where you live, you may have to excavate 18" (45 cm) or more, of topsoil to reach a stable substrate such as hard clay. If you do excavate to a depth greater than the foundation form height, you will need to add a material, such as thoroughly compacted pea gravel or crushed rock, which will allow for the drainage of water from under the concrete slab. Placing a layer of plastic sheeting over the material will help prevent it from wicking water



Casa2G and Premio2G

Residential Modular Refractory Ovens

from the slab too quickly, making it brittle and prone to cracking.

You may also want to install your oven as part of a larger outdoor kitchen project. Use the dimensions for the oven in conjunction with your other kitchen elements, such as counters, a grill, storage, a sink, and refrigeration. You might find it easier to form your entire kitchen at one time.

Hints and Tips

Use a tiller to break up the ground before you excavate. You can rent one from Home Depot. If your ground is hard and/or dry, water it with a sprinkler for a couple of days before you start. Your site should be soft, but not muddy.

Compare both diagonal measurements of your foundation frame to ensure that your foundation will be square. Double check that your foundation really faces the exact direction you want your oven to face. Once the diagonals are of equal length, you may want to temporarily attach 2"x 4" (5 x 10 cm) lumber horizontally to form triangles at the corners and hold your form square during the pour.

The weight of concrete in the foundation can be heavy (40 80 lb. bags or more), and mixing it by hand in a wheelbarrow might use up energy and time that will serve you better later in the project. Rent a mixer from Home Depot, and ask a friend (or pay a local teenager) to help you mix and pour the slab.

There are also mix-on-your-site trucks that come and just make as much concrete as you need on site, so you might want to price this option if available in your area.

Check with your local equipment rental company for a 1-yard mixer that you can tow behind a standard pickup truck.

If your building site is far from your street or curb, you can hire a concrete pump to shoot the concrete where you want it. The pump rental is typically a different company from the concrete delivery truck.

2. The Oven Stand

Overview

The oven stand is typically constructed using standard 8"x 8"x 16" (20 x 20 x 40 cm) concrete masonry units (CMU), though it can also be made from brick, metal, or formed concrete.

Instructions

Build a block stand comprised of four courses using standard 8"x 8"x 16" (20 x 20 x 40 cm) and 8"x 8"x 8" (20 x 20 x 20 cm) concrete blocks. The first three courses of the block stand form a three-sided U, leaving an opening in the oven front that provides access for wood storage. The fourth course of blocks spans the opening at the front of the U, by resting on two pieces of 2"x 2"x 3/8" (50 x 50 x 9.5 mm) angle iron.

Using a chalk line, mark the layout of your block stand directly on the foundation slab. Make sure that it faces exactly where you want your oven opening to face. Then, lay your first course of blocks directly on your slab. Use pre-mixed mortar where necessary to ensure that the first course of blocks is level, front and back, side to side, and on the diagonals.

Take your time with getting the first course set correctly, because it will be increasingly difficult to correct problems later.



2.1. Carefully lay out the first course of blocks.

Casa2G and Premio2G

Residential Modular Refractory Ovens

In the following courses, stagger your blocks using either 8"x 8"x 8" (20 x 20 x 20 cm) blocks, or cut blocks, to ensure that the joints are offset. Lay the next two courses, for a total of three.

After you have laid your first three courses, set your two pieces of 2"x 2" (5 x 5 cm) angle iron across the opening between the two legs of the U shape. Note that the back piece of angle iron must be cut to allow clearance for the rest of the top course of blocks.



2.2. Cut the back angle iron to leave room for blocks.

Grind, or cut, 3/8" (9.5 mm) from the edges of each block that rests on the angle iron, so that they lie flush with the rest of the fourth course. Finish laying the rest of the fourth course of blocks.



2.3. The finished stand.

After you have completely assembled the block stand, check that the walls are square, level and plumb. Drop a section of 1/2" (12.7 mm) rebar in every other core, and fill those cores with concrete.

Gas option: a minimum of 19 3/4" w x 19 3/4" h (50.1 cm w x 50.1 cm h) opening is required for air flow to burner assembly.

Variations

Variations include round stands, corner ovens, oven with an attached outdoor kitchen, pre-cast lintels, and metal stands.



2.4. Custom metal stand with stud frame.

Tips and Hints

When selecting the direction your oven will face, consider making sure that your opening does not face possible winds, which might disrupt your cooking and fire management.

We also recommend dry stacking your blocks, then filling every other core (or the corners) with concrete. It's a lot faster, and sturdier as well. Block the cores that you have not filled with your empty concrete bag to stop your hearth concrete from spilling into the holes.

Casa2G and Premio2G

Residential Modular Refractory Ovens

3. The Insulating Hearth

Overview

Your oven sits on a two-layer hearth, comprised of an insulating layer that rests on top of a 3 1/2" (8 cm) concrete slab. The FB Board insulation is included with the oven, is easy to install and very efficient at holding heat inside your oven. **If gas burner is being installed, there has to be a hole planned in both the concrete slab and board insulation for the burner sleeve.**

Instructions

1. Using 2"x 4" (5 x 10 cm) lumber build the frame for the bottom of the form. The frame should be roughly 3/8" (9.5 mm) smaller than the width and depth of your block stand, so that it can be easily removed after the hearth has cured.
2. Cut (12) lengths of 2"x 4" (5 x 10 cm) that will serve as the legs that hold the form in place. Use 1/4" (6.8 mm) shims to accurately set the top of the frame. The top of the 2"x 4" (5 x 10 cm) frame should be about 3/4" (19 mm) below the top of the stand (to allow for the 1/2" (12.7 mm) Hardibacker form bottom and shims).



3.1. The form bottom ready for the Hardibacker.

3. Build the sides of the form using either 2"x 4" (5 x 10 cm) or 2"x 8" (5 x 20 cm) lumber to fit around the block stand edges. The form sides will need to be supported by 2"x 4" (5 x 10 cm) legs and shims.



- 3.2 Form sides held in place with 2"x 4" supports.
4. Cut the sheets of 1/2" (12.7 mm) Hardibacker to fit inside the wood form and lay on top of the block stand. Set two 2"x 4" (5 x 10 cm) legs supporting a 2"x 4" (5 x 10 cm) on its side directly under the joint, which will support the weight of the wet hearth while it is curing.



- 3.3. Hardibacker and form set in place.
5. Build a grid of 1/2" (12.7 mm) rebar slightly shorter than the external dimension of the wood forms, on 12" (30 cm) centers, starting 6" (15 cm) in from the edges of the form, set half-way up the 3 1/2" (8 cm) concrete layer (about 1 3/4" (4 cm)).

Casa2G and Premio2G

Residential Modular Refractory Ovens



3.4 Rebar set in center of the concrete pad.

6. Pour 3 1/2" (8 cm) of standard concrete and allow for it to start curing before adding the FB Board. You do not want to install FB Board on wet concrete, as it will wick up water



3.5 Structural layer waiting on insulating layer.

7. Cut and place the FB Board insulation, making sure the insulation and the oven face straight forward and that the front of the oven is exactly where you want it.



3.6 FB Board set in place.

4. Set the Cooking Floor

Overview

Measure your hearth to ensure that you are centering your oven left and right on the hearth. How far back you set the cooking surface will depend on the size and material you are using for the oven landing in front of the oven opening. Do a trial layout using your oven landing material and your oven floor. This will help you place your oven to the correct depth on the hearth slab.

Instructions

Spread a 3/8" (9.5 mm) layer of fine sand or high temperature refractory mortar using a notched trowel. Lay your cooking surface in place, butting the joints tightly together. Check for level. This is your true cooking surface, so it is vital that it is completely level in all directions. Check again that the oven "faces" straight forward. **IMPORTANT: do not fill in side walls between floor and inner dome with mortar.** Gap is by design to allow for thermal expansion and contraction during oven use.

Casa2G and Premio2G

Residential Modular Refractory Ovens



4.1. Set the cooking floor on a thin bed of sand.



4.2. Set the vent landing level with the cooking floor.

5. Dome Assembly

Overview

The dome and vent pieces make up the oven cooking chamber and ventilation system. The oven rests on the FB Board insulation and encloses the cooking floor.

Instructions

Makes sure to dampen the oven pieces with a sponge before applying the high heat mortar included with the oven.

Only apply mortar on the outside of the oven dome pieces, not in between the pieces, otherwise thermal expansion and contraction will cause the mortar to crack and fall apart.

Set your oven dome pieces around the oven floor, taking care to ensure that each piece lies flat on the insulating hearth and lines up squarely with the other dome pieces. Push the pieces together **BEFORE** you apply the mortar. Each dome piece is designed to have no less than 1/16" (1.5 mm) gap and no more than 1/2" (12.7 cm) gap between joint fittings with 1/4" (6.3 mm) being ideal.



5.1. Line up the dome pieces.

Casa2G and Premio2G

Residential Modular Refractory Ovens



5.2. Seal the outside of the oven dome joints.

Seal the outside of the oven dome joints with a 2" w x 3/4" h (50 mm x 19 mm) band of high temp mortar.

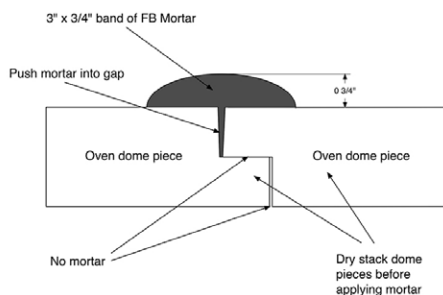

5.3. Dome assembly.

Seal the intersection between the oven dome and vent and the insulating board with a 2" w x 3/4" h (50 mm x 19 mm) band of high heat mortar.

The oven has the option of a decorative brick vent arch. The arch attaches to the front of the oven dome body and vent assembly. A custom, site-built arch can also be used, and can be constructed from virtually any non-combustible material.

You do not need to coat the outside of the oven dome with additional mortar. The oven dome is

made using a high density castable refractory material that provides excellent heat hold capacity.

6. Chimney Installation

Overview

Your oven can be attached to one of three types of chimney system: the single wall stainless steel chimney supplied with the oven, a UL103HT Listed chimney system, or a refractory chimney flue liner. **DO NOT CONNECT THIS UNIT TO A CHIMNEY FLUE SERVING ANOTHER APPLIANCE. DOING SO MAY RESULT IN FIRE.**

The table below outlines the internal dimension of the chimney system recommended for each oven size.

Oven Size	Chimney Internal Diameter
Casa2G80/90	6" (15 cm)
Casa2G/ Premio2G 100/110	8" (20 cm)
Premio2G120	8" (20 cm)

Single Wall Chimney for Outdoor Installation

Each oven contains a 24" (60 cm) section of single wall stainless steel pipe with an anchor plate and rain cap, intended for outdoor installations. Additional 24" (60 cm) sections of pipe can be added to meet specific installation requirements.

Do not use single wall chimney pipe on indoor installation.

Casa2G and Premio2G

Residential Modular Refractory Ovens



6.1 Casa2G with single wall stainless steel chimney.

UL103HT for Outdoor and Indoor Installation

The DuraTech chimney system is a UL103HT Listed for indoor and outdoor installation for solid fuel appliances, including Forno Bravo ovens. The system specifies a clearance of at least 2" (5 cm) between the chimney and any combustible materials, and a height of 24" (60 cm) above any combustible material within 10' (304 cm). Consult the chimney manufacturer's installation guide for complete details.



6.2. The DuraTech system.

The Duratech system includes an anchor plate, angle sets for chimney offsets, chimney pipe of various lengths, strapping and a spark arrester.

Steel Chimney Installation

Always follow the manufacturer's instruction for proper installation and clearances from combustible materials, and follow all relevant local building and fire codes.

To install the anchor plate you need to seal the anchor plate to the vent using the mortar provided with the oven, and hold the anchor plate in place using 3/16" x 1 1/4" (4.76 x 31.75 mm) Tapcon concrete screws. Pre-drill 5/32" (3.96 mm) holes using a masonry drill bit, then screw the anchor plate in place.



Casa2G and Premio2G

Residential Modular Refractory Ovens



6.3. Pre-drill 5/32" holes to line up with the anchor plate.



6.4. Apply a bead of refractory mortar.



6.5. Screw the anchor plate in place.



6.6. Check for level.

Masonry Chimney

For indoor installations, the minimum air space clearance between interior masonry chimneys and combustible materials shall be 2" (5 cm). Any chimney with at least one interior wall shall be treated as interior. All spaces between chimneys and floors or ceilings through which chimneys pass shall be fire stopped with non-combustible material. The fire stopping of spaces between chimneys and wood joists, beams or headers shall be galvanized steel not less thinner than 26 gage in thickness or non combustible sheet material not more thicker than 1/2" (12.4 mm).

If it is necessary to pass through combustible walls to connect the oven to a chimney liner, the following clearances must be maintained.

Method A. 12" (30 cm) Clearance to Combustible Wall Member: Using a minimum thickness 3.5" (8 cm) brick and a 5/8" (15.9 mm) minimum wall thickness clay liner, construct a wall pass-through. The clay liner must conform to ASTM C315 (Standard Specification for Clay Fire Linings) or its equivalent. Keep a minimum of 12" (30 cm) of brick masonry between the clay liner and wall combustibles. The clay liner shall run from the brick masonry outer surface to the inner surface of the chimney flue liner but not past the inner surface. Firmly grout or cement the clay liner in place to the chimney flue liner.

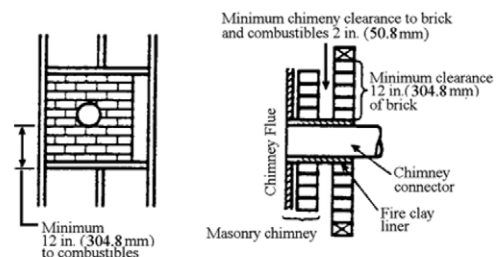

Method B. 9" (22.86 cm) Clearance to Combustible Wall Member: Using a 6" (15 cm) inside diameter, listed factory-built Solid-Pak chimney section with

Casa2G and Premio2G

Residential Modular Refractory Ovens

insulation of 1" (25.4 mm) or more, build a wall pass-through with a minimum 9" (22.86 cm) air space between the outer wall of the chimney length and wall combustibles. Use sheet metal supports fastened securely to wall surfaces on all sides, to maintain the 9" (22.86 cm) air space. When fastening supports to chimney length, do not penetrate the chimney liner (the inside wall of the Solid-Pak chimney). The inner end of the Solid-Pak chimney section shall be flush with the inside of the masonry chimney flue, and sealed with a non-water soluble refractory cement. Use this cement to also seal to the brick masonry penetration.

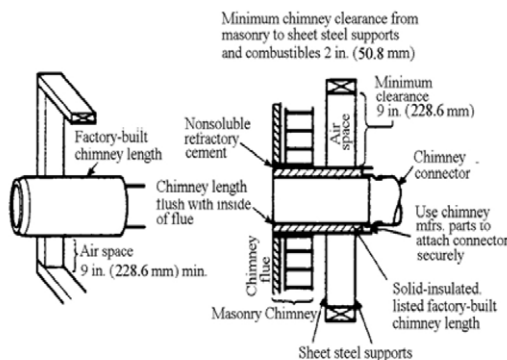

Method C. 6" (15 cm) Clearance to Combustible Wall Member: Starting with a minimum 24 gage (.024" [.61 mm]) 6" (15 cm) metal chimney connector, and a minimum 24 gage ventilated wall thimble which has two air channels of 1" (25.4 mm) each, construct a wall pass-through. There shall be a minimum 6" (15 cm) separation area containing fiberglass insulation, from the outer surface of the wall thimble to wall combustibles. Support the wall thimble, and cover its opening with a 24-gage minimum sheet metal support. Maintain the 6" (152.4 mm) space. There should also be a support sized to fit and hold the metal chimney connector. See that the supports are fastened securely to wall surfaces on all sides. Make sure fasteners used to secure the metal chimney connector do not penetrate chimney flue liner.

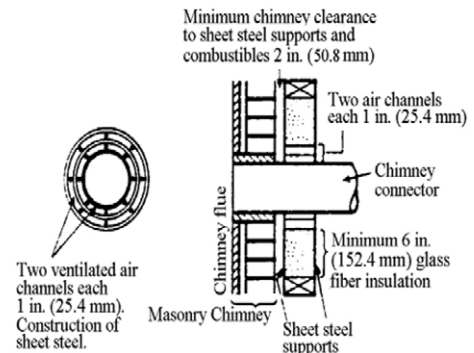

Method D. 2" (5 cm) Clearance to Combustible Wall Member: Start with a Solid-Pak listed factory built chimney section at least 12" (30 cm) long, with insulation of 1" (25.4 mm) or more, and an inside diameter of 8" (2 inches [5 cm] larger than the 6" [15 cm] chimney connector). Use this as a pass-through for a minimum 24-gage single wall steel chimney connector. Keep Solid-Pak section concentric with and spaced 1" (25.4 mm) off the chimney connector by way of sheet metal support plates at both ends of chimney section. Cover opening with and support chimney section on both sides with 24 gage minimum sheet metal supports. See that the supports are fastened securely to wall surfaces on all sides. Make sure fasteners used to secure chimney flue liner.

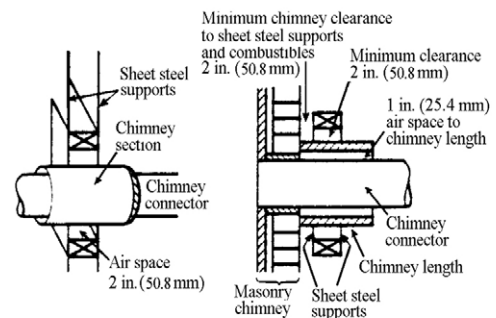

Casa2G and Premio2G

Residential Modular Refractory Ovens

7. Insulate the Oven Dome

Each oven comes with enough ceramic insulation for 3" (7 cm) on Casa series or 4" (10 cm) for Premio series pizza ovens. Be sure to fully insulate your oven to where the outside of the oven enclosure will remain cool to the touch while the oven reaches temperatures in excess of 900°F.



7.1. FB Blanket inside an Igloo frame.

Instructions

Ceramic fiber blanket insulation such as FB Blanket is easy to work with, and is easy to cut and shape. Always use a mask and gloves when working with any ceramic insulation. Take care to overlap any joints. Optionally, you can hold the insulation in place with a metal band or wire mesh.

8. Enclosure Design Styles

Overview

The oven enclosure must be sealed to protect your oven and its insulation from water. It can be constructed from concrete block, rebar and stucco mesh, metal stud and concrete board or free standing brick or stone. The style of the enclosure is up to you, your imagination, and the availability of local materials.

A MAJOR CAUSE OF OVEN-RELATED FIRES IS FAILURE TO MAINTAIN REQUIRED CLEARANCES (AIR SPACES) TO COMBUSTIBLE MATERIALS. IT IS OF UTMOST IMPORTANCE THAT THIS OVEN BE INSTALLED ONLY IN ACCORDANCE WITH THESE INSTRUCTIONS.

For design ideas, visit the [Forno Bravo photo gallery](#) or the [Forno Bravo forum](#).

9. Igloo Enclosure

Overview

The Igloo is a traditional Italian and Mediterranean pizza oven design style where the enclosure follows the basic lines of the oven dome and chimney—thus the Igloo.

Instructions

There are two ways of making the Igloo shape. First, you can create the Igloo using stucco lathe and insulating concrete. The insulating concrete is then covered with a thin finish coat of waterproof stucco.

Second, the Igloo shape can be created with rebar and stucco lathe, separately from the dome, as shown in graphic 9.1. Drill 1/4" (6.3 mm) holes around the perimeter of the oven hearth, the distance you want away from the exterior of your oven, to accommodate your insulation thickness. Insert pieces of pencil rebar in the holes, and bend them to the desired Igloo shape. Cover the pencil rebar with stucco mesh, and secure it in place with concrete tie wire to make the Igloo frame solid.

Cover the entire structure with a 1/2"-3/4" (12.7 -19 mm) undercoat of stucco, followed by a finish stucco coat to the style you prefer. Finally, seal the entire oven with a weatherproof stucco coat or paint.



Casa2G and Premio2G

Residential Modular Refractory Ovens



9.1 Rebar and lathe shape the Igloo.

10. Walled Enclosures

Overview

The Gabled House, or walled enclosure, is one of the most traditional ways to finish a brick oven. There are examples of these ovens throughout the Italian countryside.

The basic process for finishing your oven this way is straightforward. Construct walls around your oven using metal studs to a height of at least 6" higher than the top of your insulated oven dome. Face the metal studs with concrete board, and finish the exterior of the oven with stucco, brick, or stone. The roof design is up to the builder, and it can be finished with stone, clay tile or modern composite tile.

DO NOT USE WOOD or PLYWOOD TO FRAME YOUR OVEN ENCLOSURE. USE METAL STUDS AND NON COMBUSTIBLE BACKER BOARD.

Instructions

Using traditional partition wall building techniques, build a wall using a single metal stud lying flat as a bottom plate, and two metal studs lying flat as the top plates for each wall. Attach the bottom plate to the concrete hearth slab using concrete screws. Set metal studs every 16" (40 cm) in the body of the wall to support the concrete board.

Interlock the top two metal stud top plates at each corner to give the structure more strength. Set two vertical studs at each corner for a larger face to attach the concrete board, and to give the structure more strength.

The Oven Opening

Set the location of the front wall of the oven enclosure so that the brick arch at the oven opening projects forward by a couple of inches. Set one horizontal stud at the top of the arch, and set two additional studs at a 45-degree angle on the sides of the arch to provide support for the concrete board.

Finish

Attach your concrete board using metal stud screws. The gap between the oven and the enclosure walls is filled with FB Blanket.

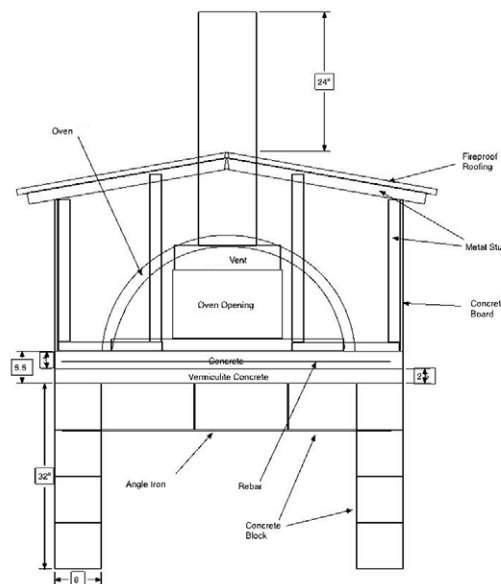

10.1. The basic walled enclosure.

Casa2G and Premio2G

Residential Modular Refractory Ovens

Tips and Techniques

Build your walled enclosure the same way you would build a partition wall using wood studs. Set the vertical studs on 15" (38 cm) centers, and always center your concrete board seams directly on your vertical studs.

Use the flat head screws design specifically for attaching concrete board to metal studs, as they do a good job of drilling into the metal studs, and leave a flat surface that can be easily finished with stucco or stone.

11. Curing Your Oven

It is important at this point that you cure your oven slowly, by building a series of five increasingly larger fires, starting with a low temperature. If you begin building large fires in your oven right way, you will compromise your oven's longevity and ability to cook well, and cause damage, including cracking.

After you have installed your oven, there is still a great deal of moisture in the mortars, hearth concrete, vermiculite, and the oven chamber and vent. Each of these oven components was recently produced using an air-drying, water-based process. Simply letting the oven stand for a week does not "cure" the moisture out of them oven.

Before you start the curing process, let the complete oven sit for one week. Then, start a series of low and growing fires, using the analog temperature gauge provided in the oven door/frame. The temperature gauge reads the oven's air temperature. For a more accurate temperature reading of the oven refractory surfaces, which can be use for many types of cooking, you can use the optional Digital Infrared Thermometer, which can be purchased in the Forno Bravo Store.

Day 1. Maintain a fire temperature of 300°F throughout the day and as long as possible into the evening.

Day 2. Repeat at 350°F.

Important Note. While it is difficult to maintain consistent, low temperature fires, it is critical for proper curing that you do not go above these temperatures during the first two days.

Day 3. Repeat at 400°F.

Day 4. Repeat at 450°F.

Day 5. Repeat at 500°F.

Close the oven door every evening to preserve dryness and heat.

For additional information on curing visit www.fornobravo.com/pompeii-oven/curing/

Important Notes

Use solid wood fuels only. DO NOT use charcoal, pressure treated lumber, chipped wood products, sappy wood such as pine, laminated wood or any material other than dry medium or hard firewood.

Do not use products not specified for use with this oven.

DO NOT USE liquid fuel (firelighter fluid, gasoline, lantern oil, kerosene or similar liquids) to start or maintain a fire.

Never use water to lower temperature inside the oven, or to extinguish the fire.

There must be a period of time between completing the masonry work and beginning the actual firing cure. Longer is better than shorter, particularly for the actual dome cement. The cement and mortar must cure first and this process is actually improved by keeping the cement moist and not letting it dry out.

Also, using a space heater can help, but only so far. It is not an alternative to fire curing. We tested a space heater in an assembled Forno Bravo precast oven for two days, then quickly heated the oven up, (don't do this at home -- it was an experiment to see what would happen to an oven that we have here) and we found



Casa2G and Premio2G

Residential Modular Refractory Ovens

that we created a very large amount of steam from the oven, mortars and vermiculite, which went on for hours and hours.

12. Wood Firing and Operation

Oven bricks are intended for direct contact with bread and/or pizza products only. All other food products must not come into contact with brick surface but should be contained within approved cookware.

Start your fire using a taste-free, odor-free fire starter and dry kindling. Build your fire up slowly, adding wood to the back and sides as the fire grows.

Continue to add wood until the oven reaches the desired temperature. Then, move the fire to one side and brush the oven floor. Only use a copper brush, and do not use steel wire brushes, natural fiber brushes or wet clothes to clean the oven floor.

The fire must be built directly on the oven floor. DO NOT elevate the fire.

You can monitor your oven temperature using the analog oven air temperature gauge provided with the oven, or with an optional Digital Infrared Thermometer.

DO NOT over fire your oven, or build a fire where flame exits the oven door opening.

BEWARE of very high temperatures in the oven and use long oven gloves and mitts to handle pots and tools. DO NOT put unprotected hands or arms inside oven while it is lit.

BEWARE of flying sparks from mouth of oven. Ensure that no combustible materials are within range of oven at any time.

DO NOT close the oven door fully while a wood fire is in the chamber. Closing the door fully will cut off

oxygen to the wood fire, causing the fire to erupt suddenly when the door is removed.

DO NOT use the oven door while gas is turned on, pilot is lit or gas fire is in chamber.

When wood fire is completely out and gas is turned off, you can fully close your oven door to conserve heat for the next use of the oven.

Never use gasoline, gasoline-type lantern fuel, kerosene, charcoal lighter fluid, or similar liquids to start or “freshen up” a fire in the oven. Keep all such liquids well away from the oven when in use.

Keep the oven door opening free of all combustible materials when the oven is in operation.

Disposal of Ashes. Ashes should be placed in a metal container with a tight-fitting lid. The closed container of ashes should be placed on a non-combustible floor, or on the ground, well away from all combustible materials pending disposal. When the ashes are disposed by burial in soil, or otherwise locally dispersed, they should be retained in the closed container until all cinders have thoroughly cooled.

Wood can be stacked in the area under the oven hearth.

For additional information on wood, visit www.fornobravo.com/tech-resources/choosing-the-right-wood/

13. Maintenance and Cleaning

The oven can be inspected through the door opening. Allow the oven to completely cool before inspecting the vent and chimney pipe for creosote build up.

Have your chimney cleaned by a professional chimney sweep if you have doubts about your ability to clean it. Use a plastic, wood, or steel brush. Do not



Casa2G and Premio2G

Residential Modular Refractory Ovens

use a brush that will scratch the stainless steel liner of your chimney. Scrub the spark arrestor with a wire brush.

To remove the Chimney Cap for cleaning, either twist counter-clockwise to remove the entire cap, or unscrew the four (4) screws that attach the cap's support legs to the cap base. The Tee Cleanout Cap can be removed by turning counter-clockwise. Be sure to replace Tee Cleanout Cap when you are finished cleaning the chimney.

Creosote – Formation and need for removal. When wood is burned slowly, it produces tar and other organic vapors that combine with expelled moisture to form creosote. The creosote vapors condense in a relatively cook oven flue and exhaust hood of a slow burning fire. As a result, creosote residue accumulates on the flue lining and exhaust hood. When ignited, this creosote makes an extremely hot fire.

The oven flue should be inspected at least twice a year to determine when creosote buildup has occurred.

When creosote has accumulated, it should be removed to reduce risk of fire.



Casa2G and Premio2G

Residential Modular Refractory Ovens

Appendix 1. Installation

Tools List

Tools

- A circular saw with three blades: general-purpose wood, metal and diamond masonry. The diamond masonry blade costs more, but last longer and cuts quickly.
- A hammer.
- A rubber mallet.
- 2'-3' level. (60 cm - 90 cm)
- Grinder (optional). You can use the grinder to cut rebar, wire, and concrete block. It will save you time from not having to frequently change blades on your circular saw.
- A chalk line.
- A builder's pencil.
- A notched tile trowel for setting the cooking floor.
- Goggles and a dust mask.
- A mixing tub.
- A hoe for mixing.
- A square-edged transfer shovels.
- A tamper.
- Concrete mixer (optional). You can rent one.
- A bucket, scrub brush and sponge for clean up.
- A garden sprayer to keep your masonry damp.



Casa2G and Premio2G

Residential Modular Refractory Ovens

Appendix 2. Material List

Please calculate your exact requirements depending on your oven size and enclosure design.

80cm/32" or 90cm/36" Oven

Foundation

- (30) 80 lb. bags of Ready-Mix concrete
- (8) 1/2" x 10' (12.7 mm x 304 cm) rebar, (4) cut to 80" (203 cm); (4) cut to 94" (238 cm)
- (4) 2"x 6"x 8' (5 x 15 x 243 cm) studs, (2) cut to 83" (210 cm); (2) cut to 94" (238 cm)
- (48) Sq ft (14.6 sq m) of wire mesh
- (12) Rebar stand-offs
- (104) Sq ft (31.6 sq m) of 6 mil plastic sheeting
- Handful of plastic zip-ties, or ball of tie wire
- 1/2 cu yd of gravel
- (1) Box 2 1/2" (6.3 cm) framing nails

Block Stand

- (50) 8"x 8"x 16" (20 x 20 x 40 cm) blocks, (12) of which are cut to 8"x 8"x 12" (20 x 20 x 50 cm)
- (5) 8"x 8"x 8" (20 x 20 x 20 cm) blocks
- (3) 1/2" x 10' 1/2" (12.7mm x 26.67cm) rebar, each cut into (3) 40" (101 cm) sections to fill nine block cores
- (14) 80 lb. bags concrete for filling every other core
- (2) 1.5"x 1.5"x 56" (3.8 x 3.8 x 142 cm) angle iron (for front span)
- (3) 60 lb. bag mortar (to level first course of blocks)

Concrete Hearth

- (2) 4'x 8'x 3/4" (121 x 243 x 22 cm) sheets of plywood or particle board
- (4) 2"x 4"x 8' (5 x 10 x 243 cm) wood studs
- (4) 2"x 6"x 8' (5 x 15 x 243 cm) wood studs
- (1) Box shims (or make your own from scrap wood)
- The rest of the 2 1/2" (6.3 cm) framing nails
- (12) 1/2" x 10' (12.7mm x 304 cm) rebar, (6) cut to 72" (182 cm); (6) cut to 84" (213 cm)
- (17) 80 lb. bags of pre-mixed concrete

100cm/40", 110cm/44" or 120cm/48" Oven

Foundation

- (46) 80 lb. bags of Ready-Mix concrete
- (8) 1/2" x 10' (12.7 mm x 304 cm) rebar, (4) cut to 80" (203 cm); (4) cut to 94" (238 cm)
- (4) 2"x 6"x 8' (5 x 15 x 243 cm) studs, two cut to 83" (210 cm); two cut to 94" (238 cm)
- (48) Sq ft (14.6 sq m) of wire mesh
- (12) Rebar stand-offs
- (104) Sq ft (31.6 sq m) of 6 mil plastic sheeting
- Handful of plastic zip-ties, or ball of tie wire
- 1/2 cu yd of gravel
- (1) Box 2 1/2" (6.3 cm) framing nails

Block Stand

- (63) 8" x 8" x 16" (20 x 20 x 40 cm) blocks, (12) of which are cut to 8" x 8" x 12" (20 x 20 x 50 cm)
- (10) 8"x 8"x 8" (20 x 20 x 20 cm) blocks
- (3) 1/2" x 10' (12.7mm x 26.67cm) rebar, each cut into three 40" (101 cm) sections to fill nine block cores
- (14) 80 lb. bags concrete for filling every other core
- (2) 1.5"x 1.5"x 56" (3.8 x 3.8 x 142 cm) angle iron (for front span)
- (3) 60 lb. bags mortar (to level first course of blocks, if needed)

Concrete Hearth

- (2) 4' x 8' x 3/4" (121 x 243 x 22 cm) sheets of plywood or particle board
- (4) 2"x 4"x 8' (5 x 10 x 243 cm) wood studs
- (4) 2"x 6"x 8' (5 x 15 x 243 cm) wood studs
- (1) Box shims (or make your own from scrap wood)
- The rest of the 2 1/2" (6.3 cm) framing nails
- (12) 1/2" x 10' (12.7mm x 304 cm) rebar, (6) cut to 72" (182 cm); (6) cut to 84" (213 cm)
- (30) 80 lb. bags of pre-mixed concrete



Casa2G and Premio2G

Residential Modular Refractory Ovens

Appendix 3. Cucina Stand Assembly

The Cucina stand is an optional modular metal stand frame for creating a “built-in” look for the Forno Bravo residential ovens. The stand consists of a metal stand frame and hearth tray, along with pre-cut and pre-drilled backer board panels that face the outside and inside of the stand and form the bottom of the hearth tray. The stand is designed to hold a customer-installed concrete hearth and decorative finish, such as stucco, stone or brick.

Assembly Instructions

1. Bolt the metal frame together and set it in place.
2. Screw the backer panels to the outside of the frame. Do not worry if there are gaps between the panels. The stand will be covered with a decorative finish.
3. Lay the top tray panel into the hearth tray and support it with a customer supplied support built using 2" x 4" (5 cm x 10cm)lumber. The support will hold the tray panel and concrete in place while the wet concrete is curing. Cut the 2" x 4" (5 cm x 10cm) lumber to make a “T” under the panel, where to top of the support touches the bottom of the panel.
4. Place a grid of 1/4" (6.3 mm)rebar running in both directions every 10" (304 cm), in the center of the tray (equal amounts of concrete above and below the rebar grid).
5. Mix and pour standard pre-mix concrete to fill the tray, and leave it to cure for 24 hours.
6. Remove the support.
7. Place the oven on top of the concrete hearth.

For additional information, watch the [installation video](#).

Do not place an assembled Forno Bravo oven inside the stand tray. The stand is not designed to accurately fit the size of any assembled oven and you will damage the oven enclosure if you try to make it fit. Pour a concrete hearth and place the assembled oven on top of the cured concrete.



Gas option: a minimum of 19 3/4" w x 19 3/4" h (50.1 cm w x 50.1 cm h) opening is required for air flow to burner assembly.

Casa2G and Premio2G

Residential Modular Refractory Ovens

Appendix 4: Instructions for Assembling the Gas Burner

Gas Specifications (gas models)

The Forno Bravo Casa2G and Premio2G Series Gas ovens are equipped with a 3/4" NPT gas connection. Have a licensed gas installer provide the hook-up and test all fittings and pipe connections for leaks. Use approved gas leak detectors (soap solutions or equivalent) over and around the fittings and pipe connections.

DO NOT USE FLAME TO TEST FOR LEAKS!

The burner manifold pressures have been adjusted and tested at the factory. A variety of factors can influence these pressures, so be sure to test the individual burner manifold pressures and adjust the valves as necessary to achieve the required pressures. Note: The gas valves are shipped in the 'on' position.

Gas Supply Pressure

Natural Gas: 5 to 10 inches WC

Liquid Propane: 10 to 12 inches WC

The gas supply must be capable of providing at least 51,000 BTU's at listed pressures.

Forno Bravo recommends that the appliance's individual shutoff valve (supplied by others) be left readily accessible. Forno Bravo also recommends that inspection and maintenance of the burners and gas piping connections of this appliance be performed at regularly scheduled intervals and only by professional gas appliance service agencies.

Gas Code Limitations

The installation of this appliance must conform with local codes, or in the absence of local codes, with the National Fuel Gas Code, ANSI Z223.1/NFPA 54, the Natural Gas installation Code CAN/CGA-B149.1, or the Propane Installation Code, CAN/CGA-B149.2, as applicable, including:

The appliance and its individual shutoff valve (supplied by others) must be disconnected from the gas supply piping system during any pressure testing of that system at test pressures in excess of 1/2 psi (3.45 kPa).

The appliance must be isolated from the gas supply piping system by closing its individual manual shutoff valve (supplied by others) during any pressure testing of the gas supply piping system at test pressure, equal to or less than 1/2 psi (3.45 kPa).

WARNING: If pilot light goes out, use gas leak detector to check for gas build up before reigniting.

To install the burner, proceed as follows:

The natural gas/liquid propane supply must be delivered through a galvanized pipe Ø 1/2" (12.7 mm) or equivalent copper pipe, located at the burner inlet hole, 2" (5 cm) from the ground. Install the gas shut-off valve in a suitable position up-line.

Remember to clean the flue carefully in order to free it from any ashes generated by the combustion of the wood.



Casa2G and Premio2G

Residential Modular Refractory Ovens

Gas Burner Assembly Parts



1. Burner Body
2. Mounting Sleeve
3. Remote Thermometer
4. Gas Leak Detector
5. Regulator and Hose (Liquid Propane Only)
6. Ignition Control Box

Casa2G and Premio2G

Residential Modular Refractory Ovens

Assembly Instructions for Drago Burner *Outdoor Installation*

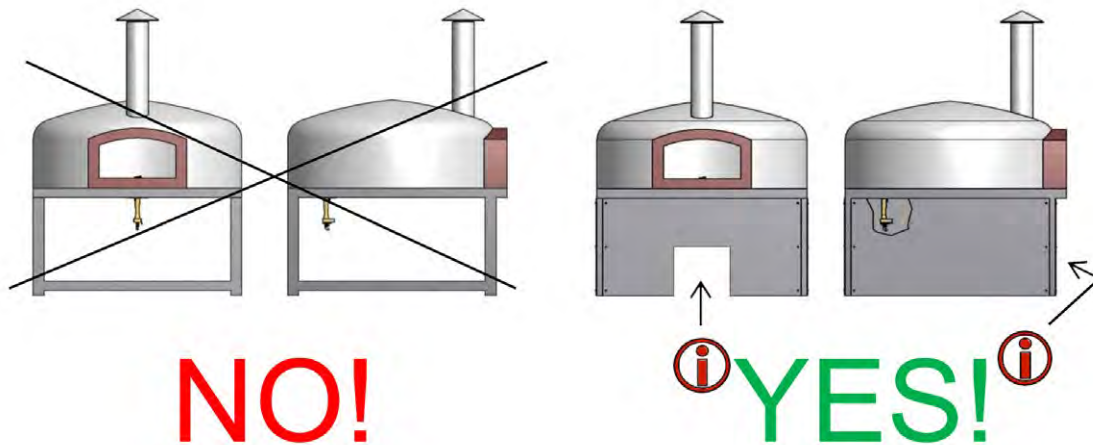

For the burner to work properly, the external walls of the oven support frame should be closed on all sides. It is necessary to create an air intake opening, measuring at least 20" x 20" (500 mm x 500 mm), located underneath the oven door/opening, as shown in the diagrams above. The reason for this is that the air must be taken from the same environment in which the oven chamber opens.



Casa2G and Premio2G

Residential Modular Refractory Ovens

FIXING FLANGE P1 TO THE OVEN

The flange with tube (photo 1) must be fixed under the oven with the two burner fixing stud bolts at 90° to the oven opening (photo 2).

The stud bolt welded in the center must always be positioned towards the bottom of the oven (photo 3).

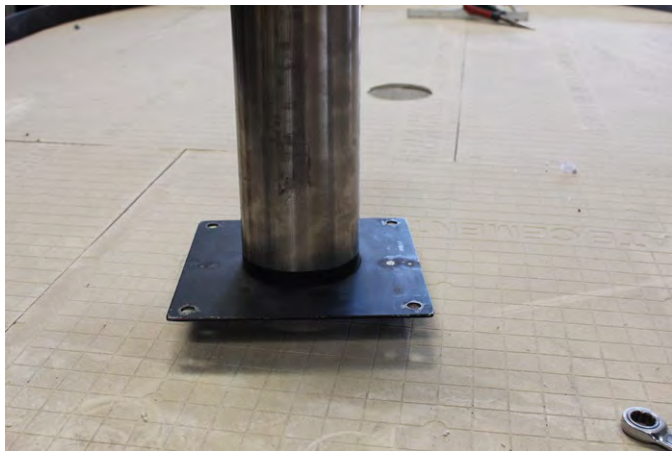

Photo 1



Photo 2



Photo 3



Casa2G and Premio2G

Residential Modular Refractory Ovens

To install the burner, carry out the following operations:

Fix the flange with tube made to measure for the thickness of the oven floor to the oven, bearing in mind that it must protrude from the baking floor by about 1" (2 cm) (photos 1 and 2).



Photo 1



Photo 2

Position the burner body in the flange seat and fix it with two nuts 8 MA, taking care to insert a spacer to allow entry of secondary air (photo 3).

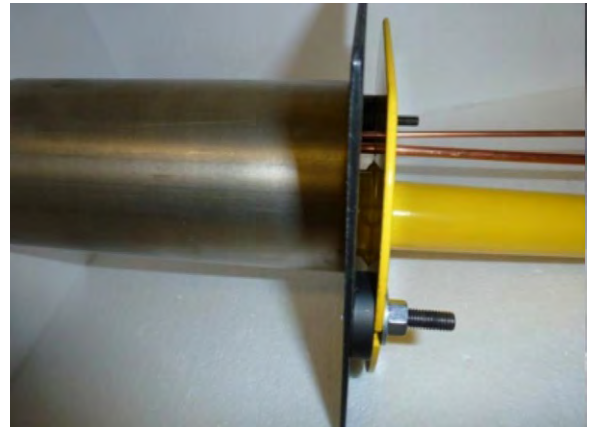

Photo 3

Secure the valve control box (photo 4) under the oven opening so that it is easily accessible (photo 5).



Photo 4

Casa2G and Premio2G

Residential Modular Refractory Ovens



Photo 5

Make all the connections from the valve (photo 6) to the burner, as follows:

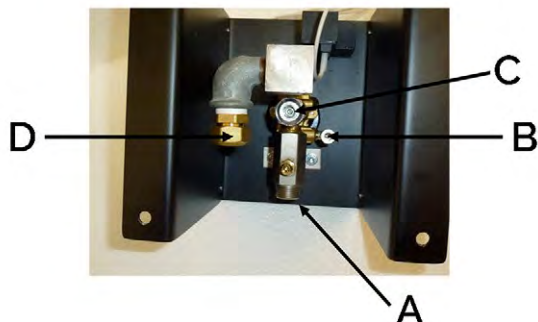

Photo 6

- A. Arrival of gas to the pipe; a type approved flexible gas pipe \varnothing 1/2" (12.7mm) can be used.
- B. Outlet of copper pipe \varnothing 6 that carries gas to the pilot flame.
- C. Thermocouple inlet; be careful not to over tighten the nut.
- D. Outlet of copper pipe \varnothing 12 that carries gas to the main burner.

Insert the burner ignition cable in its insulator (photos 7-8).



Photo 7



Photo 8



Vent the pipe and check that it is completely airtight.

Casa2G and Premio2G

Residential Modular Refractory Ovens

IDENTIFICATION OF THE BURNER

The identification plate shown below has been affixed to the burner described in this manual.

MODELLO DRAGO P/1Plus	N. DI MATRICOLA P1/	TIPO DI GAS
ANNO DI COSTRUZIONE	POTENZA TERMICA DA	KW A KW
CATEGORIA <input type="checkbox"/> I _{2E} <input type="checkbox"/> I _{2E+} <input type="checkbox"/> I ₃₊ <input type="checkbox"/> II _{2H3+} <input checked="" type="checkbox"/> II _{2H3B/P} <input type="checkbox"/> II _{2E+3+} <input type="checkbox"/> II _{2E3B/P} <input type="checkbox"/>		
PAESI <input type="checkbox"/> AT <input type="checkbox"/> DE <input type="checkbox"/> BE <input type="checkbox"/> CH <input type="checkbox"/> DK <input type="checkbox"/> ES <input type="checkbox"/> FI <input type="checkbox"/> FR <input type="checkbox"/> IE <input type="checkbox"/> IT <input checked="" type="checkbox"/> PT <input type="checkbox"/> GB <input type="checkbox"/> SE <input type="checkbox"/>		
PRESSIONE GAS DA mbar A mbar	 AVANZINI BRUCIATORI S.R.L. VIA BATTISTINI N. 11 43122 - PARMA - ITALY TEL 0521/27.13.44 FAX 0521/77.58.62	
ALIMENTAZIONE ELETTRICA		
POTENZA ELETTRICA		

This plate may never be removed and must always be kept in legible condition. If it gets damaged, a replacement must be requested from the company **AVANZINI BRUCIATORI s.r.l.**. The burner cannot be sold without the plate.

Modello:	Model
N. di matricola:	Registration Number
Tipo di gas:	Type Of Gas
Anno di costruzione:	Year Of Manufacture
Potenza termica:	Thermic Power
Categoria:	Category
Paesi:	Countries
Pressione gas:	Gas Pressure

Casa2G and Premio2G

Residential Modular Refractory Ovens

TECHNICAL SPECIFICATIONS

P1 Plus Technical Specifications for Natural Gas

MODEL	THERMAL CAPACITY				GAS PRESSURE		GAS VOLUME		GAS CONNECTION	WEIGHT
	<i>in Kw</i>		<i>in Kcal/h</i>		<i>in mbar</i>		<i>in Nm3/h</i>		<i>in INCHES</i>	<i>in KG</i>
	<i>Min.</i>	<i>Max.</i>	<i>Min.</i>	<i>Max.</i>	<i>Min.</i>	<i>Max.</i>	<i>Min.</i>	<i>Max.</i>		
DRAGO P1 Plus	11	24	9.460	20.640	10	25	1,16	2,54	1/2	5

Standard natural gas nozzle bore Ø 2.75.

The pressure of the gas when the burner is lit must be 13 ~ 20 mbar.

Natural gas regulator must be supplied by local certified installer.

P1 Plus Technical Specifications for Liquid Propane Gas

MODEL	THERMAL CAPACITY				GAS PRESSURE		GAS VOLUME		GAS CONNECTION	WEIGHT
	<i>in Kw</i>		<i>in Kcal/h</i>		<i>in mbar</i>		<i>in Nm3/h</i>		<i>in INCHES</i>	<i>in KG</i>
	<i>Min.</i>	<i>Max.</i>	<i>Min.</i>	<i>Max.</i>	<i>Min.</i>	<i>Max.</i>	<i>Min.</i>	<i>Max.</i>		
DRAGO P1 Plus	11	24	9.460	20.640	25	35	0,79	1,72	1/2	5

Standard Liquid Propane Gas nozzle bore Ø 2.25.

The pressure of the gas when the burner is lit must be 30 ~ 35 mbar.

Gas orifice sizes must not be changed without contacting manufacturer, manufacturer's representative or local service representative. Changing gas orifice sizes can present fire and carbon monoxide poisoning hazards if not done correctly.

Natural Gas Orifice Size = 2.75

Liquid Propane Orifice Size = 2.25

Casa2G and Premio2G

Residential Modular Refractory Ovens

BURNER LIGHTING

It is *important* that the oven door be OPEN both when turning the burner on and all the time is burner is running.

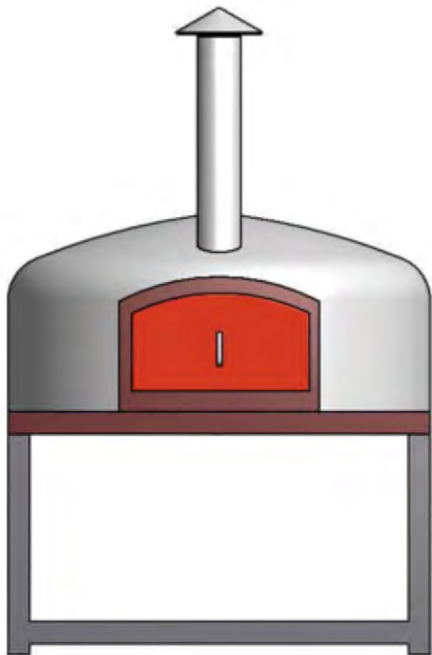

NO!

IMPORTANT!!!

The door must be closed only AFTER the burner has been turned off.

This is because the open door creates the necessary draft for the chimney, and allows in the secondary air necessary for the burner.

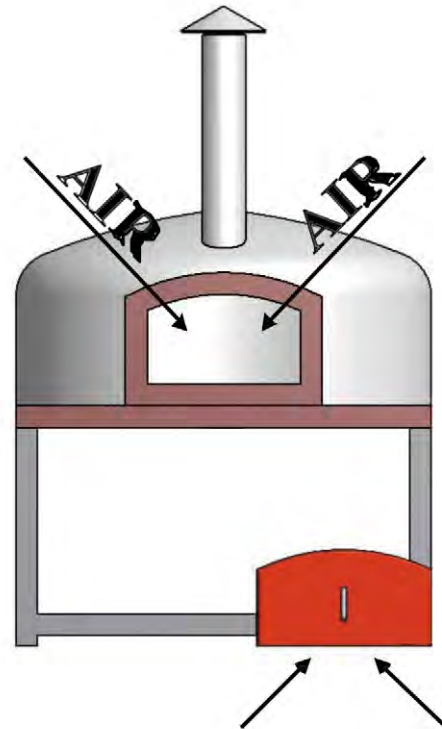

YES!



Casa2G and Premio2G

Residential Modular Refractory Ovens

BURNER'S IGNITION AND ADJUSTMENT

To turn on the pilot flame the knob must be pressed and turned counterclockwise to the position N.1 (star). Keep the knob pressed (which enables exit of the gas from the pilot unit) together with the piezoelectric button to spark ignition, and ignite the pilot flame (photo 9).



Photo 9

The first ignition may take extra time for all the air inside the copper pipe Ø 6 supplying the pilot unit to come out. Continue to hold the ignition until all the three flames of the head of the pilot are on, for a correct ignition of the main burner (photo 10).



Photo 10

Press and rotate clock wise the knob and position it on the high flame position N.2 (large flame) (photo 11).



Photo11

WARNING: If pilot light goes out, use gas leak detector to check for gas build up before reigniting (photo 12).



Photo12

Casa2G and Premio2G

Residential Modular Refractory Ovens

Remove the knob and adjust the height of the high flame by adjusting the screw, as shown in photos 13-14, usually the right capacity is obtained when the flame reaches the oven's dome center.



Photo 13



Photo 14

Put the knob in place and turn it counterclockwise to the low flame position (photo 15).



Photo 15

Take out the knob and adjust the height of the low flame by turning the screw as shown in photo 16; it must be about half the height of the high flame.

(In any case, when on low flame, the oven temperature must never rise, but be maintained)



Photo 16

Casa2G and Premio2G

Residential Modular Refractory Ovens

Insert the knob again. The low flame and the high flame are pre-adjusted and the heat demand can be changed with the knob according to the product to be baked.

To turn the main burner's flame off and leave the pilot only on, position the knob on the star (photo 17).



Photo 17

To turn the main burner and the pilot flame off completely the knob must be positioned on the black point (photo 18).

The flame must be soft, silent and yellow-colored, but it must not stain the dome of the oven. To obtain it, it is necessary to regulate the air intake: the shutter should be in position n. 2 for natural gas, in position n. 3 for liquid propane. (photo 18).



Photo 18



Casa2G and Premio2G

Residential Modular Refractory Ovens

Curing Your Gas Oven

Forno Bravo recommends curing the oven with wood, not gas, due to the gas burner not allowing a low enough flame setting during the cure process. Direct flame touching the dome prior to the oven being cured properly can result in cracking the dome and voiding the warranty. Refer to Section 11 (page 29) in this manual for curing instructions.

Small "HAIRLINE" cracks CAN occur IN THE OVEN DOME with normal heating and cooling. They will not AFFECT the performance or LONGEVITY of the oven. If cracks of 1/8" or more develop, contact Forno Bravo Customer Service.

Maintenance and Cleaning

The oven can be inspected through the door opening. Allow the oven to completely cool before inspecting the vent and chimney pipe for creosote build up.

Have your chimney cleaned by a professional chimney sweep if you have doubts about your ability to clean it. Use a plastic, wood, or steel brush. Do not use a brush that will scratch the stainless steel liner of your chimney. Scrub the spark arrestor with a wire brush.

To remove the Chimney Cap for cleaning, either twist counter-clockwise to remove the entire cap, or unscrew the four (4) screws that attach the cap's support legs to the cap base. The Tee Cleanout Cap can be removed by turning counter-clockwise. Be sure to replace Tee Cleanout Cap when you are finished cleaning the chimney.

Creosote – Formation and need for removal. When wood is burned slowly, it produces tar and other organic vapors that combine with expelled moisture to form creosote. The creosote vapors condense

in a relatively cook oven flue and exhaust hood of a slow burning fire. As a result, creosote residue accumulates on the flue lining and exhaust hood. When ignited, this creosote makes an extremely hot fire.

The oven flue should be inspected at least twice a year to determine when creosote buildup has occurred.

When creosote has accumulated, it should be removed to reduce risk of fire.

The oven can inspected through the door opening. Allow the oven to completely cool before inspecting the vent and chimney pipe for creosote build up. Have your chimney cleaned by a professional chimney sweep if you have doubts about your ability to clean it. Use a plastic, wood, or steel brush. Do not use a brush that will scratch the stainless steel liner of your chimney. Scrub the spark arrestor with a wire brush.

To remove the Chimney Cap for cleaning, either twist counter-clockwise to remove the entire cap, or unscrew the four (4) screws that attach the cap's support legs to the cap base. The Tee Cleanout Cap can be removed by turning counter-clockwise. Be sure to replace Tee Cleanout Cap when you are finished cleaning the chimney. Creosote – Formation and need for removal. When wood is burned slowly, it produces tar and other organic vapors that combine with expelled moisture to form creosote. The creosote vapors condense in a relatively cook oven flue and exhaust hood of a slow burning fire. As a result, creosote residue accumulates on the flue lining and exhaust hood.

When ignited, this creosote makes an extremely hot fire. The oven flue should be inspected at least twice a year to determine when creosote buildup has occurred.



Casa2G and Premio2G

Residential Modular Refractory Ovens

When creosote has accumulated, it should be removed to reduce risk of fire.

Cleaning Burner Nozzle

After unscrewing the nozzle, use soap and water to wipe off any creosol that is on the nozzle . Proceed with a can of compressed air to blow out any ash or debris that may have fallen down the head of the burner. Screw nozzle back on when complete. (Cleaning of your nozzles should be done once) every 6-8 months.



Casa2G and Premio2G

Residential Modular Refractory Ovens

Changing The Battery

If the burner stops igniting, you may need to change the battery under the piezoelectric button. Unscrew cap by turning counter-clockwise



Photo 1
Remove dead battery.



Photo 2

Replace with new AA battery.



Photo 3
Tighten cap.



Photo 4



Casa2G and Premio2G

Residential Modular Refractory Ovens

REPLACING THE NOZZLE

REPLACING THE BURNER NOZZLE

Unscrew the brass nozzle placed on the burner using a .78" (20 mm) wrench (photos 1- 2).

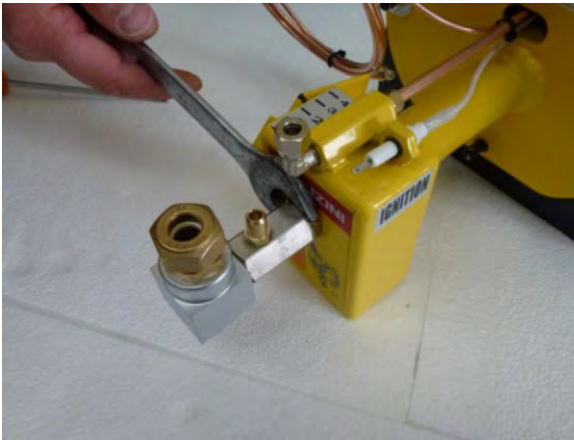

Photo 1



Photo 2

Unscrew the burner's nozzle counterclockwise by means of a 20 size wrench, replace it and screw all the components again following the sequence backwards (photo 3).



Photo 3



Casa2G and Premio2G

Residential Modular Refractory Ovens

REPLACING THE FLAMEBREAKER

Unscrew the Allen screws using a 4 mm Allen key and extract the flamebreaker (photo 1). Replace it with the relevant “natural gas” or “liquid propane” flamebreaker (photos 1, 2, 3 and 4).

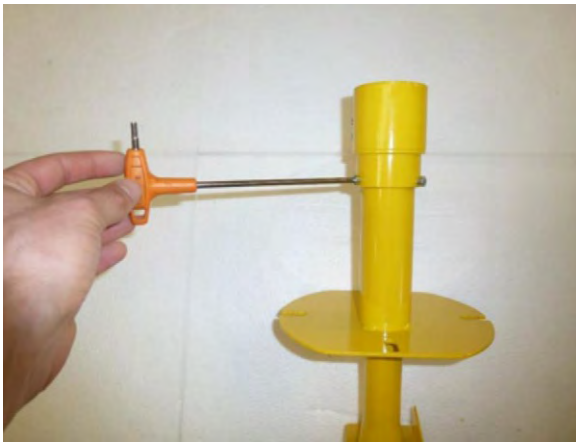

Photo 1



Photo 3



Photo 2



Photo 4



Casa2G and Premio2G

Residential Modular Refractory Ovens

Appendix 5. Oven Dimensions

Casa2G 80 Wood	53
Casa2G 90 Wood	59
Casa2G 100 Wood	65
Casa2G 110 Wood	71
Premio2G 100 Wood	77
Premio2G 110 Wood	83
Premio2G 120 Wood	89
Casa2G 80 Gas	95
Casa2G 90 Gas	102
Casa2G 100 Gas	109
Casa2G 110 Gas	116
Premio2G 100 Gas	123
Premio2G 110 Gas	130
Premio2G 120 Gas	137

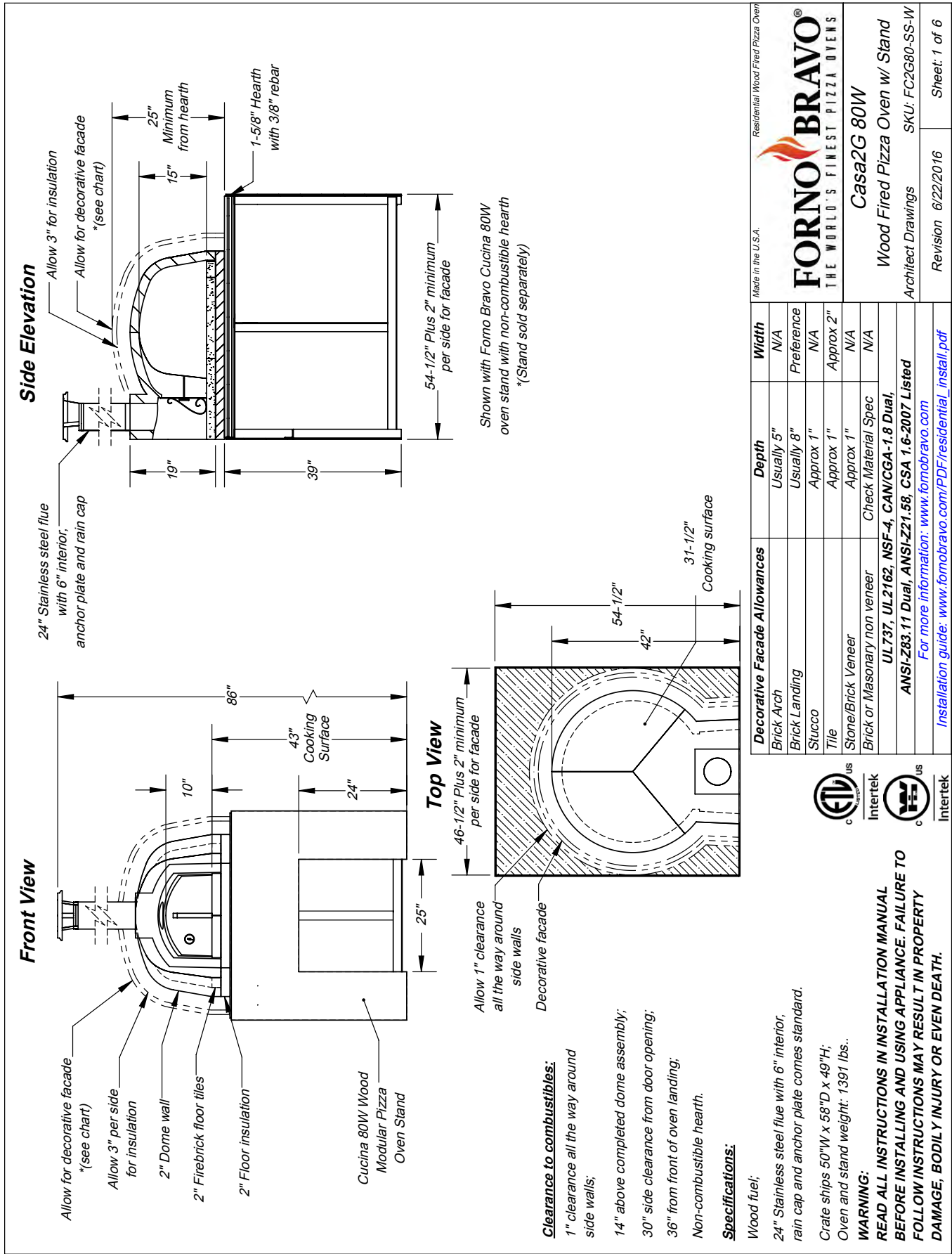

Made in the U.S.A.		Residential Wood Fired Pizza Oven	
FORNO BRAVO® THE WORLD'S FINEST PIZZA OVENS		Width	N/A
Casa2G 80W		Depth	Usually 5"
Wood Fired Pizza Oven w/ Stand			Usually 8"
Architect Drawings			Approx 1"
Revision 6/22/2016			Approx 1"
SKU: FC2G80-SS-W			Approx 1"
Sheet: 1 of 6			Check Material Spec
		Decorative Facade Allowances	N/A
		Brick Arch	UL 737, UL 2162, NSF-4, CAN/CGA-1.8 Dual,
		Brick Landing	ANSI-Z83.11 Dual, ANSI-Z21.58, CSA 1.6-2007 Listed
		Situcco	For more information: www.fornobravo.com
		Tile	Installation guide: www.fornobravo.com/PDF/residential_install.pdf
		Stone/Brick Veneer	
		Brick or Masonry non veneer	



Clearance to combustibles:
 1" clearance all the way around side walls;
 14" above completed dome assembly;
 30" side clearance from door opening;
 36" from front of oven landing;
 Non-combustible hearth.

Specifications:
 Wood fuel;
 24" Stainless steel flue with 6" interior, rain cap and anchor plate comes standard.
 Crate ships 50"W x 58"D x 49"H;
 Oven and stand weight: 1391 lbs..

WARNING:
 READ ALL INSTRUCTIONS IN INSTALLATION MANUAL BEFORE INSTALLING AND USING APPLIANCE. FAILURE TO FOLLOW INSTRUCTIONS MAY RESULT IN PROPERTY DAMAGE, BODILY INJURY OR EVEN DEATH.

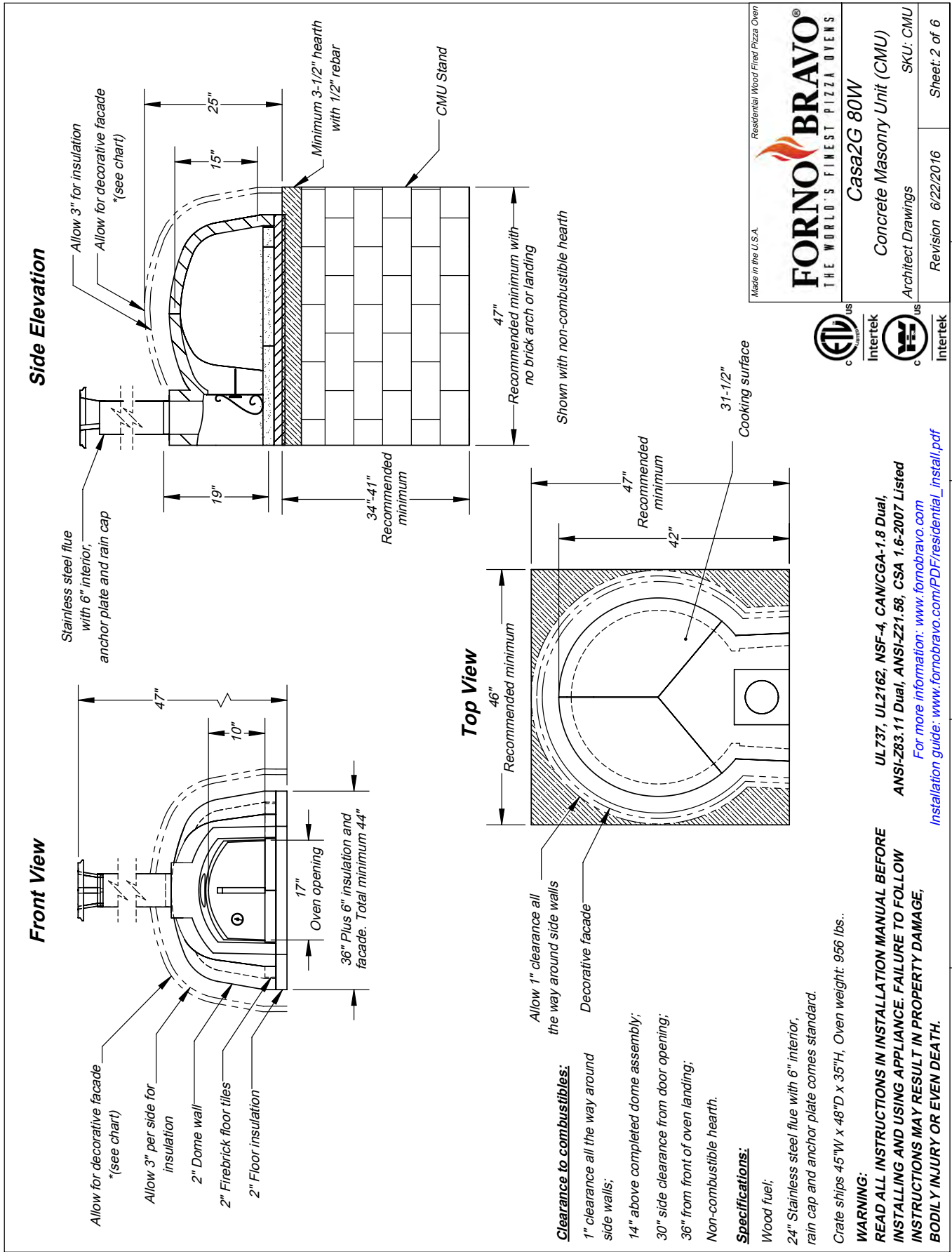

ISO View

Steel reinforced hearth requires
1-5/8" thick concrete pad with 3/8" rebar.
Do not use vermiculite in concrete
mix on this pad with Cucina stand.
*(Not included. See installation guide)

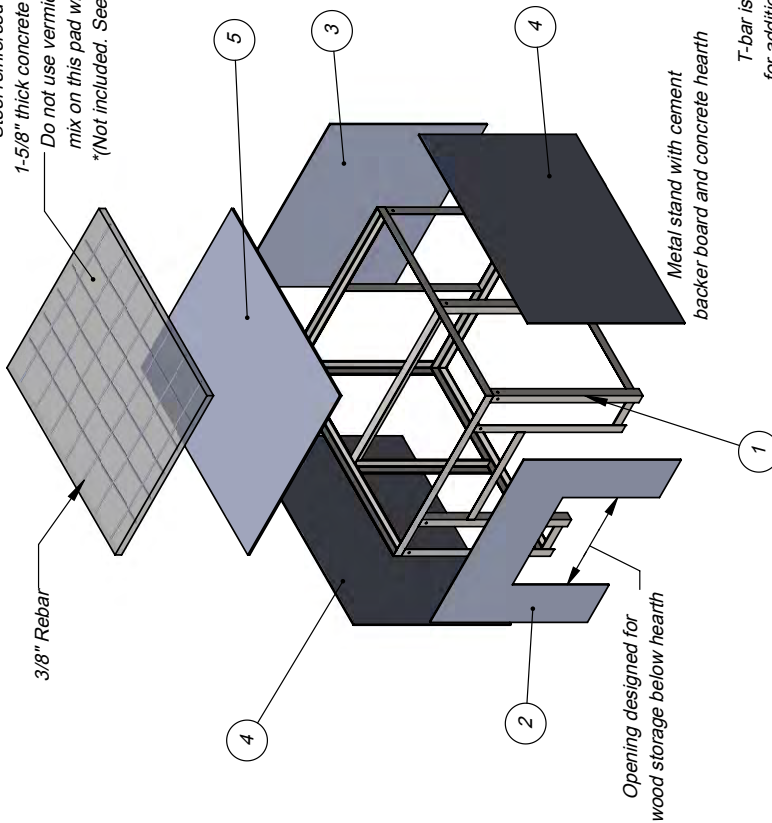

Add 2-1/2" per side
for backer board
and facade minimum

Front View

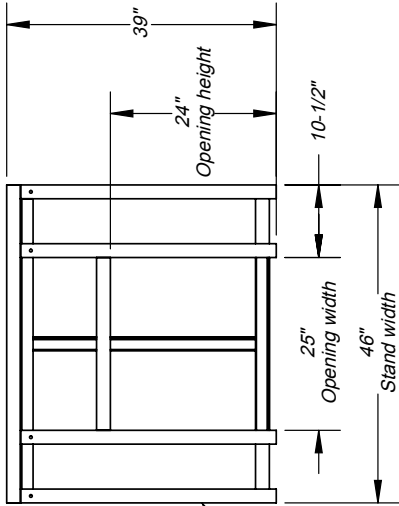

Side Elevation

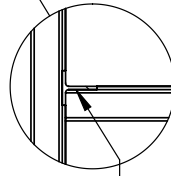
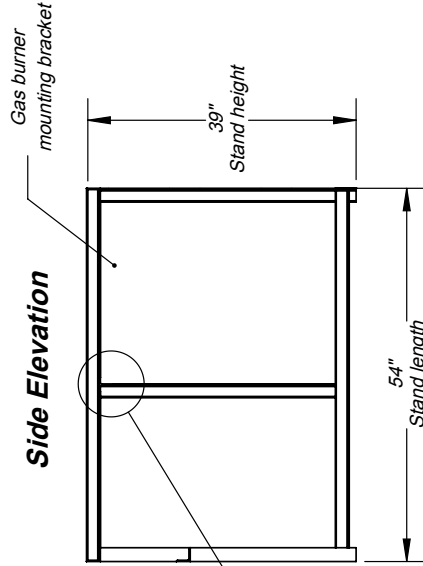

DETAIL A
SCALE 1 : 10

Specifications:

Stand includes metal frame, assembly hardware,
precut / predrilled exterior cement backer board panels.

The Cucina 80W stand works with Casa2G 80W oven.

*Hearth materials not included. See installation guide.

WARNING:

**READ ALL INSTRUCTIONS IN INSTALLATION MANUAL BEFORE
INSTALLING AND USING APPLIANCE. FAILURE TO FOLLOW
INSTRUCTIONS MAY RESULT IN PROPERTY DAMAGE,
BODILY INJURY OR EVEN DEATH.**

For more information: www.fornobravo.com

Installation guide: www.fornobravo.com/PDF/residential_install.pdf



Made in the U.S.A.

Residential Wood Fired Pizza Oven

ITEM#	PART NAME	DESCRIPTION	QTY
1	Cucina2G 80W	Metal frame substructure	1
2	Front Panel	1/4" Pre-cut Backer Board	1
3	Back Panel	1/4" Pre-cut Backer Board	1
4	Side Panel	1/4" Pre-cut Backer Board	2
5	Top Panel	1/2" Pre-cut Backer Board	1
6	Hex Bolt, 3/8" x 1"	*Not displayed	10
7	Hex Nut, 3/8"	*Not displayed	10
8	Self Tapping Screw	*Not displayed	55
	*Concrete Hearth	* See installation guide	
	*Rebar	* See installation guide	

FORNO BRAVO®
THE WORLD'S FINEST PIZZA OVENS

Cucina 80W
Wood Fired Pizza Oven Stand

Architect Drawings SKU: ICS80W
Revision 6/22/2016 Sheet: 3 of 6

5 4 3 2 1

ISO View

5-1/2" Reinforced concrete pad

1/2" Rebar

Wire mesh

Top View

Side Elevation

5-1/2"

64-1/2"

2-3/4" Rebar and wire mesh

Specifications:

- Minimum 5-1/2" deep concrete pad;
- Reinforced with 1/2" rebar and wire mesh. * wire mesh is not shown in some views for print clarity;
- Cut rebar and wire mesh short to conceal inside concrete pad;
- *CMU stand requires a minimum cement foundation pad of 54"W x 57"D

Slab dimensions:

- Minimum 8" wider than oven stand and hearth;
- Minimum 10" deeper than oven stand and hearth;
- Finished slab should be 2" to 3" above ground level;

Refer to local building codes for recommendations regarding soil compaction, frost line and other considerations. Depending on local conditions, you may have to excavate down 18" or more of topsoil to reach stable substrate.

WARNING:
READ ALL INSTRUCTIONS IN INSTALLATION MANUAL BEFORE INSTALLING AND USING APPLIANCE. FAILURE TO FOLLOW INSTRUCTIONS MAY RESULT IN PROPERTY DAMAGE, BODILY INJURY OR EVEN DEATH.

Casa2G 80W oven stand footprint
 (*See specifications for CMU stand)

Top View

Side Elevation

Specifications:

- Minimum 5-1/2" deep concrete pad;
- Reinforced with 1/2" rebar and wire mesh. * wire mesh is not shown in some views for print clarity;
- Cut rebar and wire mesh short to conceal inside concrete pad;
- *CMU stand requires a minimum cement foundation pad of 54"W x 57"D

Slab dimensions:

- Minimum 8" wider than oven stand and hearth;
- Minimum 10" deeper than oven stand and hearth;
- Finished slab should be 2" to 3" above ground level;

Refer to local building codes for recommendations regarding soil compaction, frost line and other considerations. Depending on local conditions, you may have to excavate down 18" or more of topsoil to reach stable substrate.

WARNING:
READ ALL INSTRUCTIONS IN INSTALLATION MANUAL BEFORE INSTALLING AND USING APPLIANCE. FAILURE TO FOLLOW INSTRUCTIONS MAY RESULT IN PROPERTY DAMAGE, BODILY INJURY OR EVEN DEATH.

Casa2G 80W oven stand footprint
 (*See specifications for CMU stand)

Top View

Side Elevation

Specifications:

- Minimum 5-1/2" deep concrete pad;
- Reinforced with 1/2" rebar and wire mesh. * wire mesh is not shown in some views for print clarity;
- Cut rebar and wire mesh short to conceal inside concrete pad;
- *CMU stand requires a minimum cement foundation pad of 54"W x 57"D

Slab dimensions:

- Minimum 8" wider than oven stand and hearth;
- Minimum 10" deeper than oven stand and hearth;
- Finished slab should be 2" to 3" above ground level;

Refer to local building codes for recommendations regarding soil compaction, frost line and other considerations. Depending on local conditions, you may have to excavate down 18" or more of topsoil to reach stable substrate.

WARNING:
READ ALL INSTRUCTIONS IN INSTALLATION MANUAL BEFORE INSTALLING AND USING APPLIANCE. FAILURE TO FOLLOW INSTRUCTIONS MAY RESULT IN PROPERTY DAMAGE, BODILY INJURY OR EVEN DEATH.

Made in the U.S.A.

FORNO BRAVO®
 THE WORLD'S FINEST PIZZA OVENS

Residential Wood Fired Pizza Oven

Casa2G 80W
 Wood Fired Pizza Oven Pad

Architect Drawings

Revision 6/22/2016

Sheet 4 of 6

ETL Intertek

ETL Intertek

For more information: www.fornobravo.com
 Installation guide: www.fornobravo.com/PDF/residential_install.pdf

1 2 3 4 5

Front View

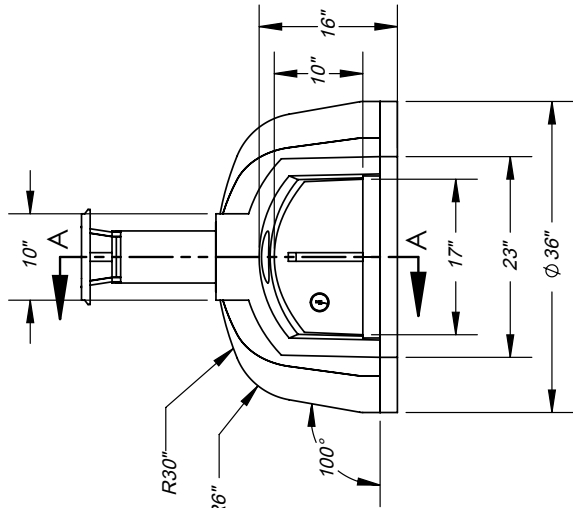

Casa2G 80W Pizza Oven Kit includes:

- Commercial grade refractory oven dome with integral vent
- 2" ceramic fiber insulation board
- 3" ceramic fiber insulation blanket (multiple 1" thick blankets)
- NSF-4 rated fireclay cooking surface
- High temp refractory mortar to seal dome joints
- Single wall stove pipe, anchor plate, 24" pipe and cap
- Single wall steel powder coated door
- Door thermometer

Sold separately:

- UL certified spark arrestor
- Decorative brick arch
- Double wall insulated steel door to retain heat longer
- Cucina stand with steel frame and hardie-backer board precut
- Stove pipe extensions
- Upgrade to double wall chimney for indoor installations / covered patios
- Pizza Oven Tools, infrared thermometer, gloves and other items

To be provided by customer / contractor:

- Concrete support pad with rebar (or equivalent structure)
- Concrete masonry stand (CMU) or equivalent non-combustible structure
- Decorative facade materials (stucco, brick, tile, steel, etc.)

Certifications:

Tested and compliant with:
 UL737, UL2162, NSF-4, CAN/CGA-1.8 Dual, ANSI-Z83.11 Dual, ANSI-Z21.58, CSA 1.6-2007
 For more information about our certifications, click here: www.fornobravo.com/ul-certified

WARNING:

READ ALL INSTRUCTIONS IN INSTALLATION MANUAL BEFORE INSTALLING AND USING APPLIANCE. FAILURE TO FOLLOW INSTRUCTIONS MAY RESULT IN PROPERTY DAMAGE, BODILY INJURY OR EVEN DEATH.
 Installation manual can be found by clicking on this link: www.fornobravo.com/PDF/residential_install.pdf

Side Elevation

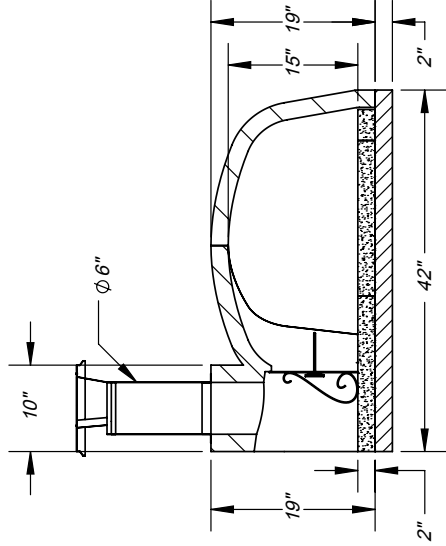

SECTION A-A
SCALE 1 : 20

Top View

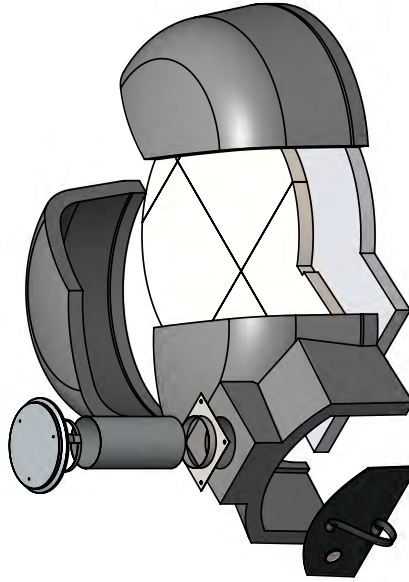
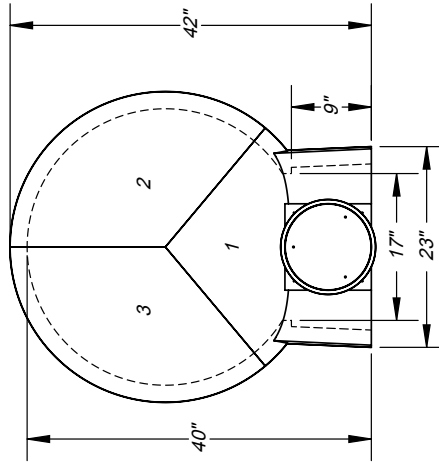

Made in the U.S.A. Residential Wood Fired Pizza Oven

FORNO BRAVO®
 THE WORLD'S FINEST PIZZA OVENS

Casa2G 80W
 Wood Fired Pizza Oven
 Architect Drawings

Revision 6/22/2016 Sheet 5 of 6



5 4 3 2 1

ISO View

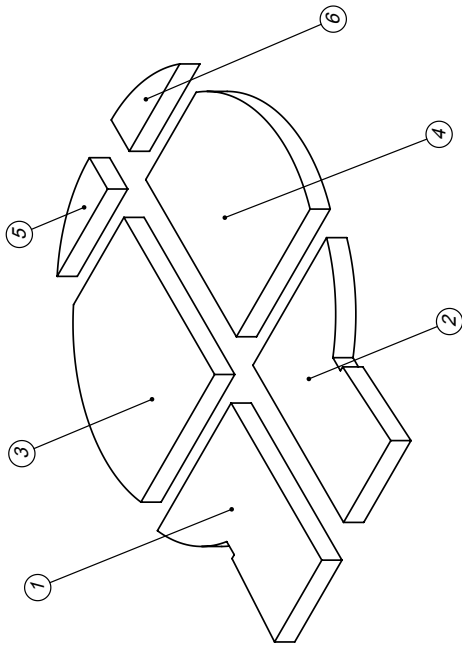

When ordering replacement tiles, reference tile number, pizza oven model and date of purchase.

Top View

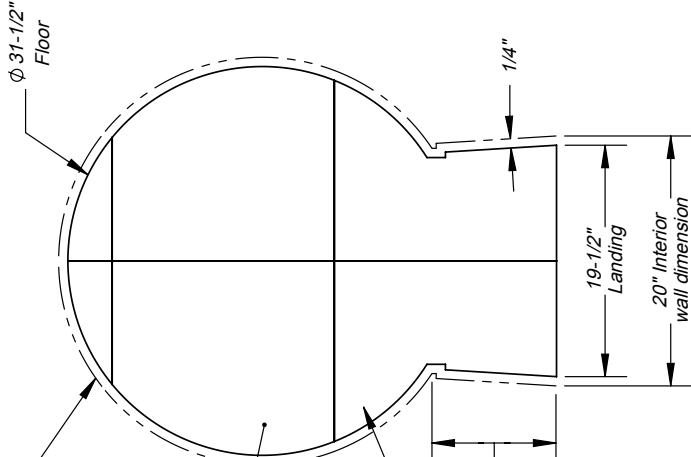

ϕ 32" Interior dome dimension

ϕ 31-1/2" Floor

Floor designed to allow approximately 1/2" gap between cooking surface and interior dome for thermal expansion and contraction during operation.

Do not fill inside wall with mortar or similar bonding agent. If preferred the space can be filled with sand.

Gaps between the wall and front landing can be filled with mortar or equivalent bonding agent.

19-1/2" Landing

20" Interior wall dimension

1/4"

Side Elevation

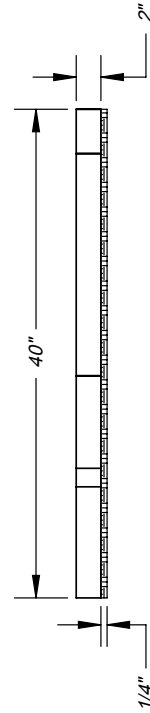

1/4" mortar, sairsset, or #60 mesh sand to level pizza oven floor.

Specifications:

Pizza oven floor is NSF-4 rated with 2" thick surface.

Use 1/4" mortar, sairsset or #60 mesh sand to level the pizza oven floor.

No more than 3/8" filler around landing or door may not fit.

WARNING:

READ ALL INSTRUCTIONS IN INSTALLATION MANUAL BEFORE INSTALLING AND USING APPLIANCE. FAILURE TO FOLLOW INSTRUCTIONS MAY RESULT IN PROPERTY DAMAGE, BODILY INJURY OR EVEN DEATH.

Made in the U.S.A.

Residential Wood Fired Pizza Oven



Casa2G 80W

Pizza Oven Floor Tile Layout
Architect Drawings

Revision 6/22/2016 Sheet: 6 of 6



For more information: www.fornobravo.com
Installation guide: www.fornobravo.com/PDF/residential_install.pdf

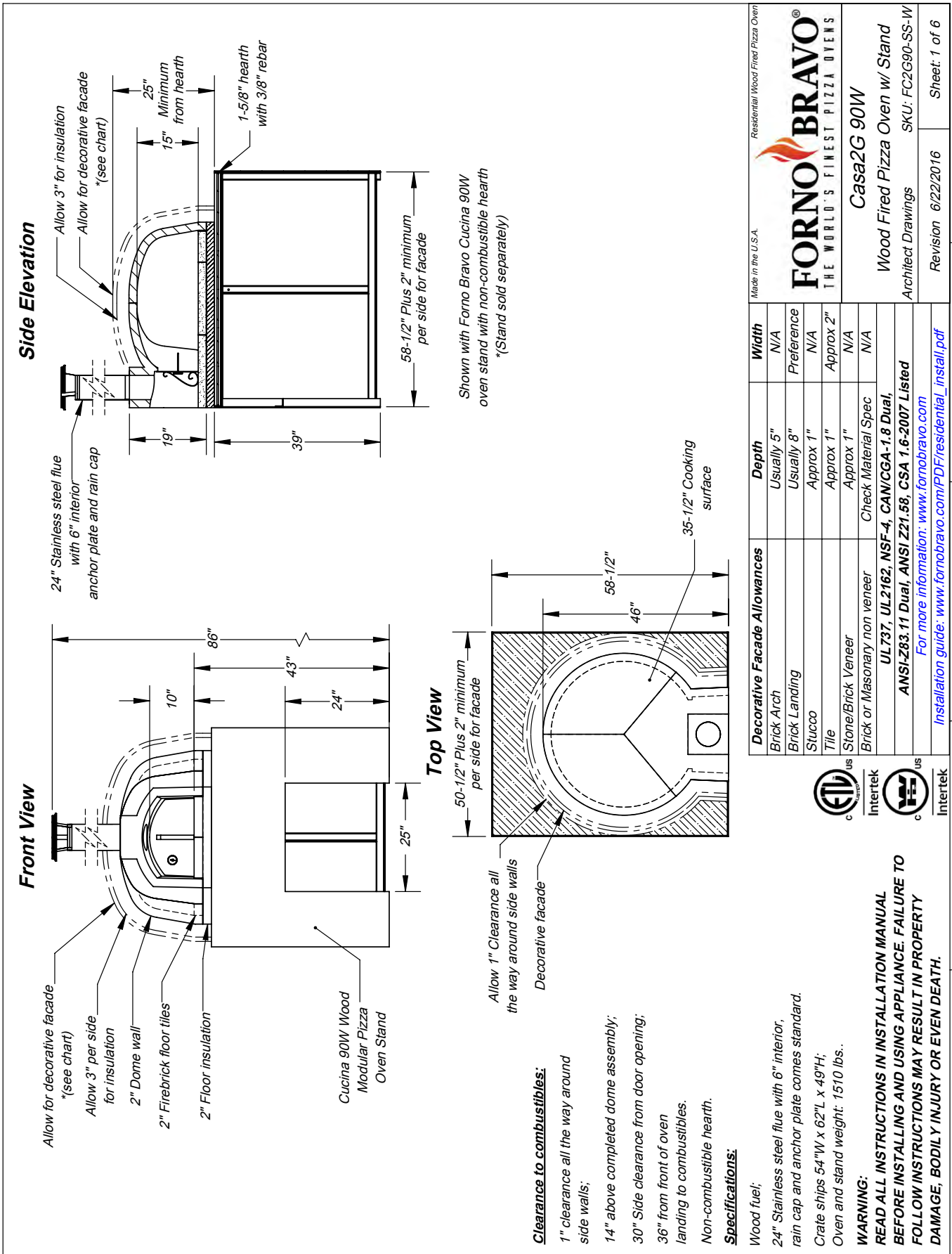

Shown with Forno Bravo Cucina 90W oven stand with non-combustible hearth *(Stand sold separately)

Clearance to combustibles:

- 1" clearance all the way around side walls;
- 14" above completed dome assembly;
- 30" Side clearance from door opening;
- 36" from front of oven landing to combustibles.
- Non-combustible hearth.

Specifications:

Wood fuel;
 24" Stainless steel flue with 6" interior, rain cap and anchor plate comes standard.
 Crate ships 54"W x 62"L x 49"H;
 Oven and stand weight: 1510 lbs..

WARNING:
 READ ALL INSTRUCTIONS IN INSTALLATION MANUAL BEFORE INSTALLING AND USING APPLIANCE. FAILURE TO FOLLOW INSTRUCTIONS MAY RESULT IN PROPERTY DAMAGE, BODILY INJURY OR EVEN DEATH.

Made in the U.S.A.		Residential Wood Fired Pizza Oven	
FORNO BRAVO® THE WORLD'S FINEST PIZZA OVENS		Casa2G 90W	
Wood Fired Pizza Oven w/ Stand		Architect Drawings	
Revision 6/22/2016		SKU: FC2GG90-SS-W	
Revision 6/22/2016		Sheet: 1 of 6	
Decorative Facade Allowances	Depth	Width	
Brick Arch	Usually 5"	N/A	
Brick Landing	Usually 8"	Preference	
Stucco	Approx 1"	N/A	
Tile	Approx 1"	Approx 2"	
Stone/Brick Veneer	Approx 1"	N/A	
Brick or Masonry non veneer	Check Material Spec	N/A	
UL737, UL2162, NSF-4, CAN/CGA-1.8 Dual, ANSI-Z83.11 Dual, ANSI Z21.58, CSA 1.6-2007 Listed			
For more information: www.fornobravo.com			
Installation guide: www.fornobravo.com/PDF/residential_install.pdf			



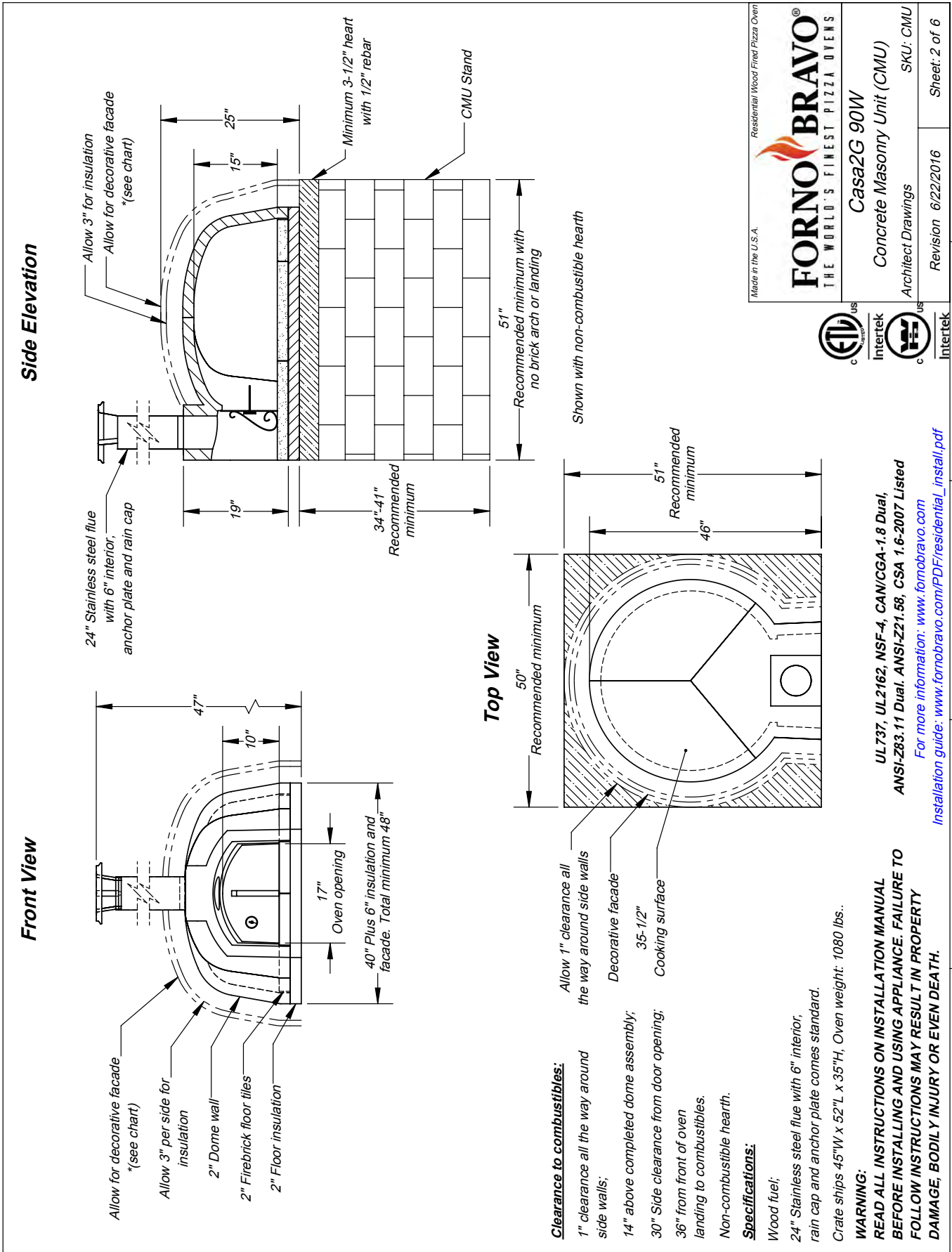

Clearance to combustibles:

- 1" clearance all the way around side walls;
- 14" above completed dome assembly;
- 30" Side clearance from door opening;
- 36" from front of oven landing to combustibles.
- Non-combustible hearth.

Specifications:

- Wood fuel;
- 24" Stainless steel flue with 6" interior, rain cap and anchor plate comes standard.
- Crate ships 45"W x 52"L x 35"H. Oven weight: 1080 lbs..

WARNING:

READ ALL INSTRUCTIONS ON INSTALLATION MANUAL BEFORE INSTALLING AND USING APPLIANCE. FAILURE TO FOLLOW INSTRUCTIONS MAY RESULT IN PROPERTY DAMAGE, BODILY INJURY OR EVEN DEATH.

UL737, UL2162, NSF-4, CAN/CGA-1.8 Dual, ANSI-Z83.11 Dual. ANSI-Z21.58, CSA 1.6-2007 Listed
 For more information: www.fornobravo.com
 Installation guide: www.fornobravo.com/PDF/residential_install.pdf

Made in the U.S.A. Residential Wood Fired Pizza Oven

FORNO BRAVO®
 THE WORLD'S FINEST PIZZA OVENS

Casa2G 90W
 Concrete Masonry Unit (CMU)
 Architect Drawings SKU: CMU
 Revision 6/22/2016 Sheet: 2 of 6



ISO View

Steel reinforced hearth requires
1-5/8" thick concrete pad with 3/8" rebar.
Do not use vermiculite in concrete
mix on this pad with Cucina stand.
*(Not included. See installation guide)

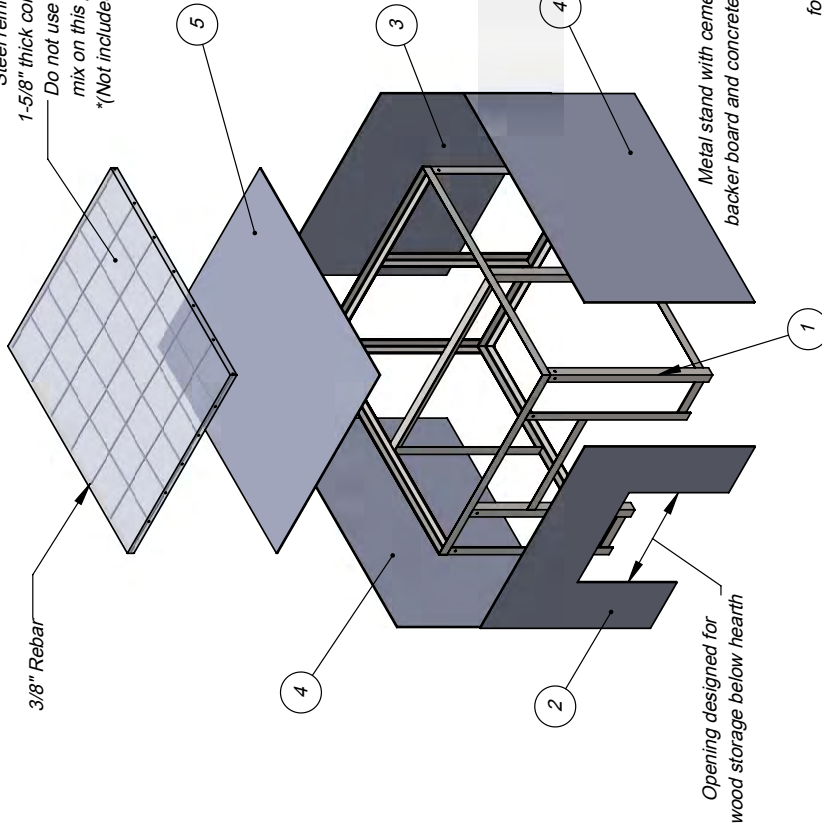

Add 2-1/2" per side
for backer board and
minimum facade

Opening designed for
wood storage below hearth

Specifications:

Stand includes metal frame, assembly hardware,
precut / prefilled exterior cement backer board panels.

The Cucina 90W stand works with Casa2G 90W oven.

* Hearth materials not included. See installation guide.

WARNING:

**READ ALL INSTRUCTIONS IN INSTALLATION MANUAL
BEFORE INSTALLING AND USING APPLIANCE. FAILURE TO
FOLLOW INSTRUCTIONS MAY RESULT IN PROPERTY
DAMAGE, BODILY INJURY OR EVEN DEATH.**

For more information: www.fornobravo.com
Installation guide: www.fornobravo.com/PDF/residential_install.pdf



Front View

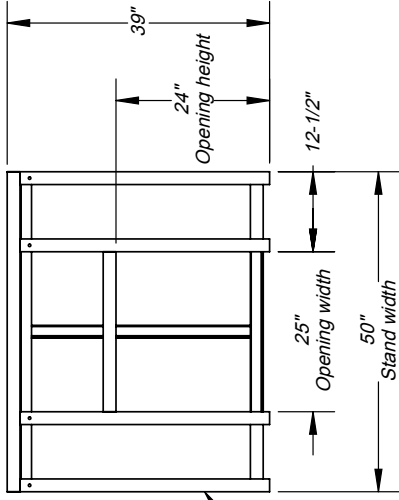

Side Elevation

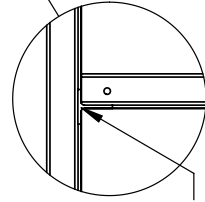
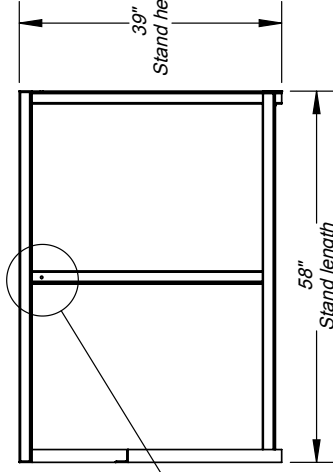

T-bar is welded in
for additional strength

DETAIL A
SCALE 1 : 10

ITEM#	PART NAME	DESCRIPTION	QTY
1	Cucina2G 90W	Metal frame substructure	1
2	Front Panel	1/4" Pre-cut Backer Board	1
3	Back Panel	1/4" Pre-cut Backer Board	1
4	Side Panel	1/4" Pre-cut Backer Board	2
5	Top Panel	1/2" Pre-cut Backer Board	1
6	Hex Bolt, 3/8" x 1"	*Not displayed	10
7	Hex Nut, 3/8"	*Not displayed	10
8	Self Tapping Screw	*Not displayed	55
	*Concrete Hearth	* See installation guide	
	*Rebar	* See installation guide	

Made in the U.S.A.

Residential Wood Fired Pizza Oven



Cucina 90W
Wood Fired Pizza Oven Stand
Architect Drawings
Revision 6/22/2016
SKU: ICS90W
Sheet: 3 of 6

ISO View

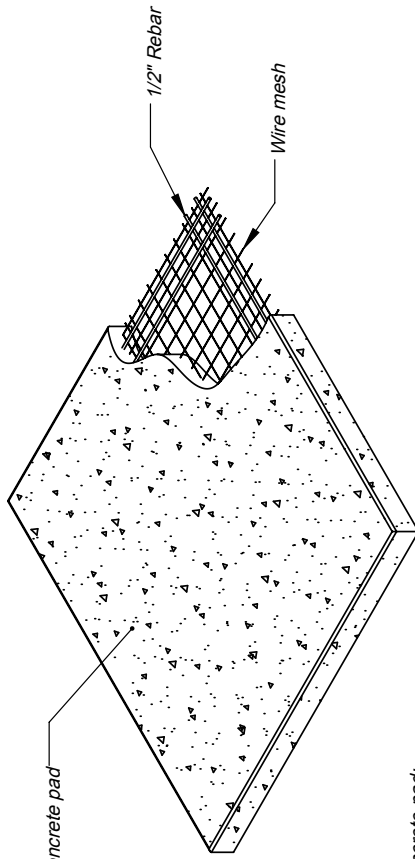

Top View

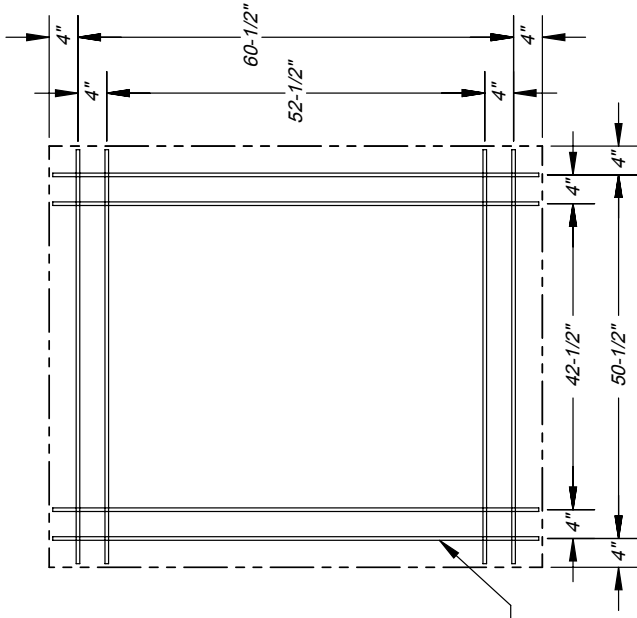

Side Elevation

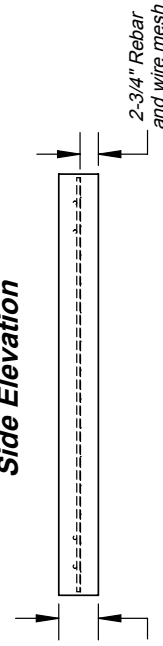

Casa2G 90W oven stand footprint
 (*See specifications for CMU stand)

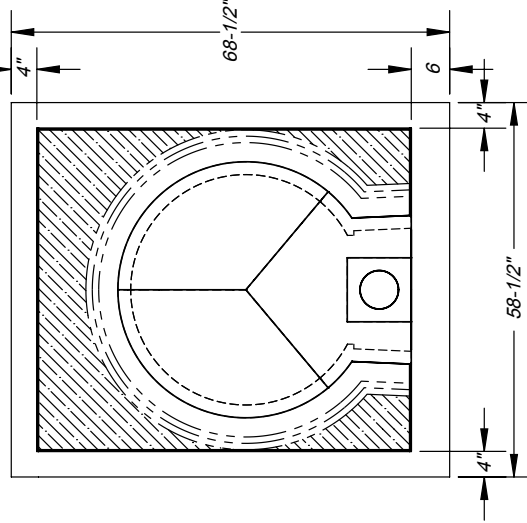

Specifications:

Minimum 5-1/2" deep concrete pad;

Reinforced with 1/2" rebar and wire mesh. *wire mesh is not shown in some views for print clarity;

Cut rebar and wire mesh short to conceal inside concrete pad;

*CMU stand requires a minimum cement foundation pad of 58"W x 61"D

Slab dimensions:

Minimum 8" wider than oven stand and hearth;

Minimum 10" deeper than oven stand and hearth;

Finished slab should be 2" to 3" above ground level;

Refer to local building codes for recommendations regarding soil compaction, frost line and other considerations. Depending on local conditions, you may have to excavate down 18" or more of topsoil to reach stable substrate.

WARNING:

READ ALL INSTRUCTIONS IN INSTALLATION MANUAL BEFORE INSTALLING AND USING APPLIANCE. FAILURE TO FOLLOW INSTRUCTIONS MAY RESULT IN PROPERTY DAMAGE, BODILY INJURY OR EVEN DEATH.

Made in the U.S.A. Residential Wood Fired Pizza Oven



Casa2G 90W
 Wood Fired Pizza Oven Pad
 Architect Drawings

Revision 6/22/2016 Sheet: 4 of 6

For more information: www.fornobravo.com
 Installation guide: www.fornobravo.com/PDF/residential_install.pdf

Front View

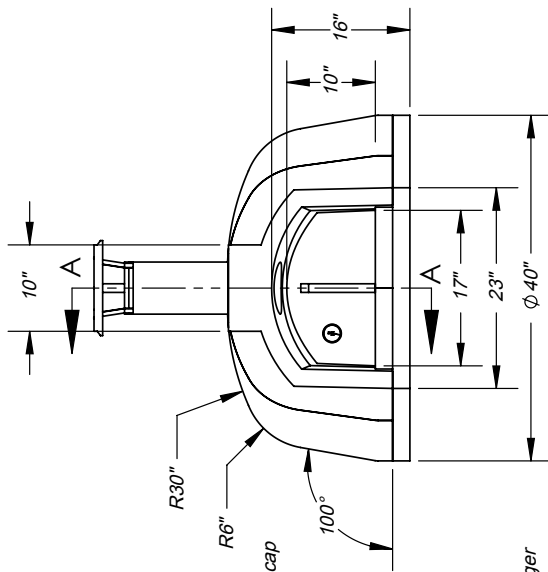

Casa2G 90W Pizza Oven Kit includes:

- Commercial grade refractory oven dome with integral vent
- 2" ceramic fiber insulation board
- 3" ceramic fiber insulation blanket (multiple 1" thick blankets)
- NSF-4 rated fireclay cooking surface
- High temp refractory mortar to seal dome joints
- Single wall stove pipe, anchor plate, 24" pipe and cap
- Single wall steel powder coated door
- Door thermometer

Sold separately:

- UL certified spark arrestor
- Decorative brick arch
- Double wall insulated steel door to retain heat longer
- Cucina stand with steel frame and hardie-backer board precut
- Stove pipe extensions
- Upgrade to double wall chimney for indoor installations / covered patios
- Pizza Oven Tools, infrared thermometer, gloves and other items

To be provided by customer / contractor:

- Concrete support pad with rebar (or equivalent structure)
- Concrete masonry stand (CMU) or equivalent non-combustible structure
- Decorative facade materials (stucco, brick, tile, steel, etc.)

Certifications:

Tested and compliant with:
 UL 737, UL2162, NSF-4, CAN/CGA-1.8 Dual, ANSI-Z83.11 Dual, ANSI-Z21.58-CSA 1.6-2007
 For more information about our certifications, click here: www.fornobravo.com/ul-certified

WARNING:

READ ALL INSTRUCTIONS IN INSTALLATION MANUAL BEFORE INSTALLING AND USING APPLIANCE.
FAILURE TO FOLLOW INSTRUCTIONS MAY RESULT IN PROPERTY DAMAGE, BODILY INJURY OR EVEN DEATH
 Installation manual can be found by clicking on this link: www.fornobravo.com/PDF/residential_install.pdf

Side Elevation

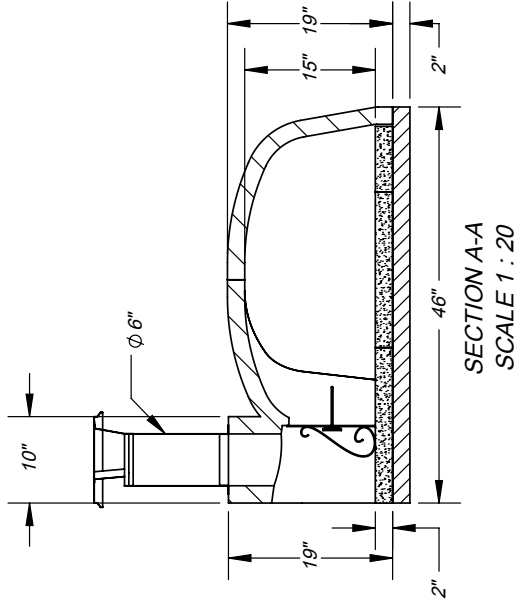

SECTION A-A
 SCALE 1 : 20

Top View

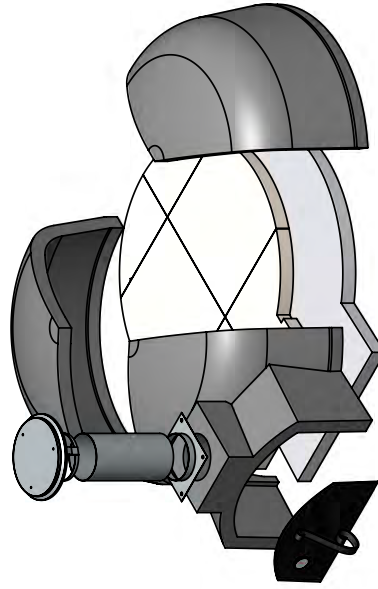
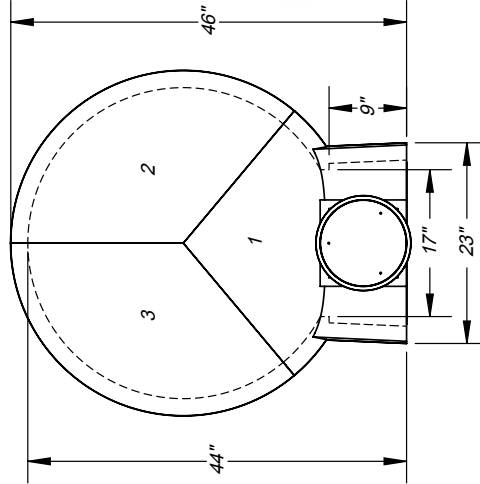

Made in the U.S.A. Residential Wood Fired Pizza Oven

FORNO BRAVO®
 THE WORLD'S FINEST PIZZA OVENS

Casa2G 90W
 Wood Fired Pizza Oven
 Architect Drawings

Revision 6/22/2016 Sheet 5 of 6



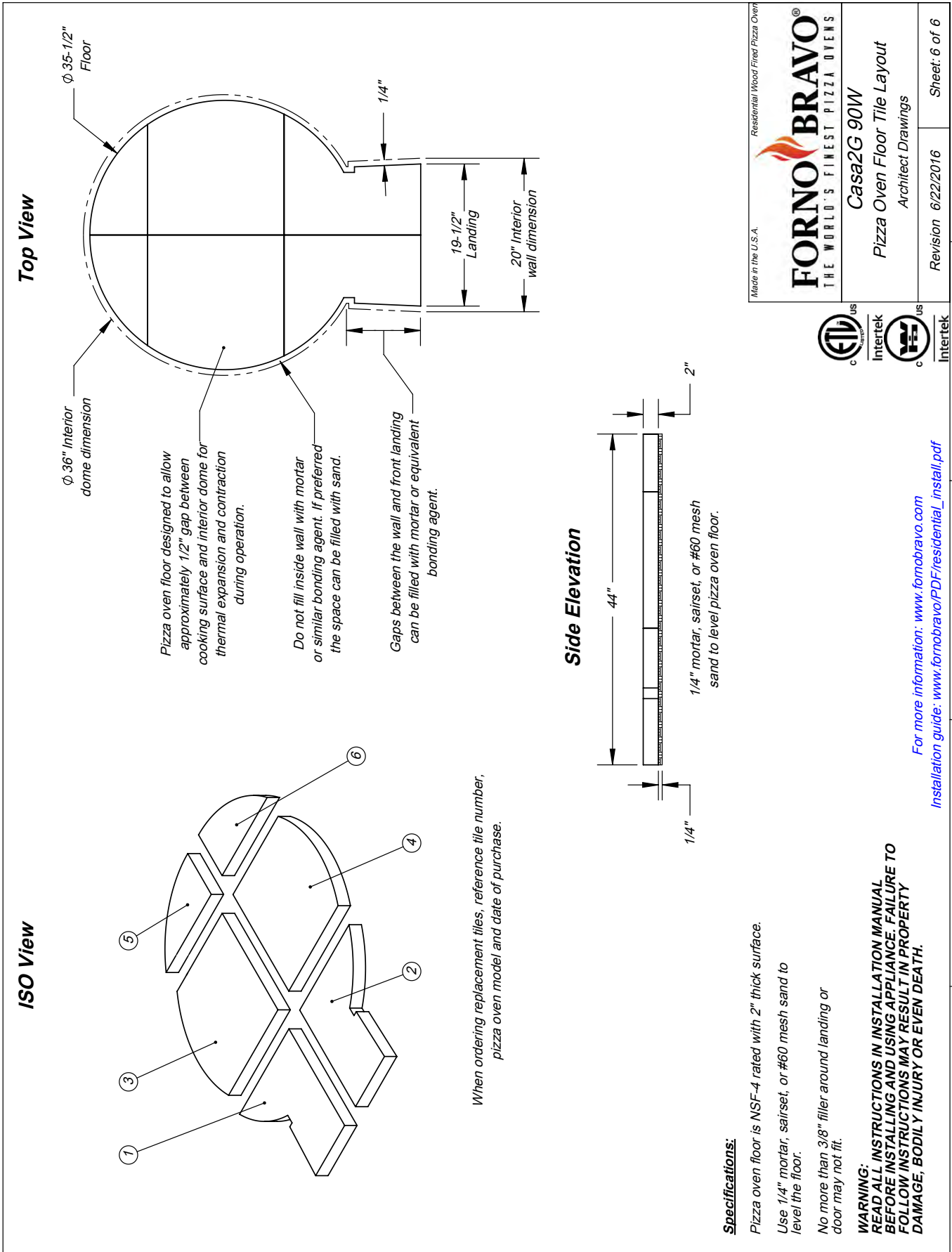

1 2 3 4 5

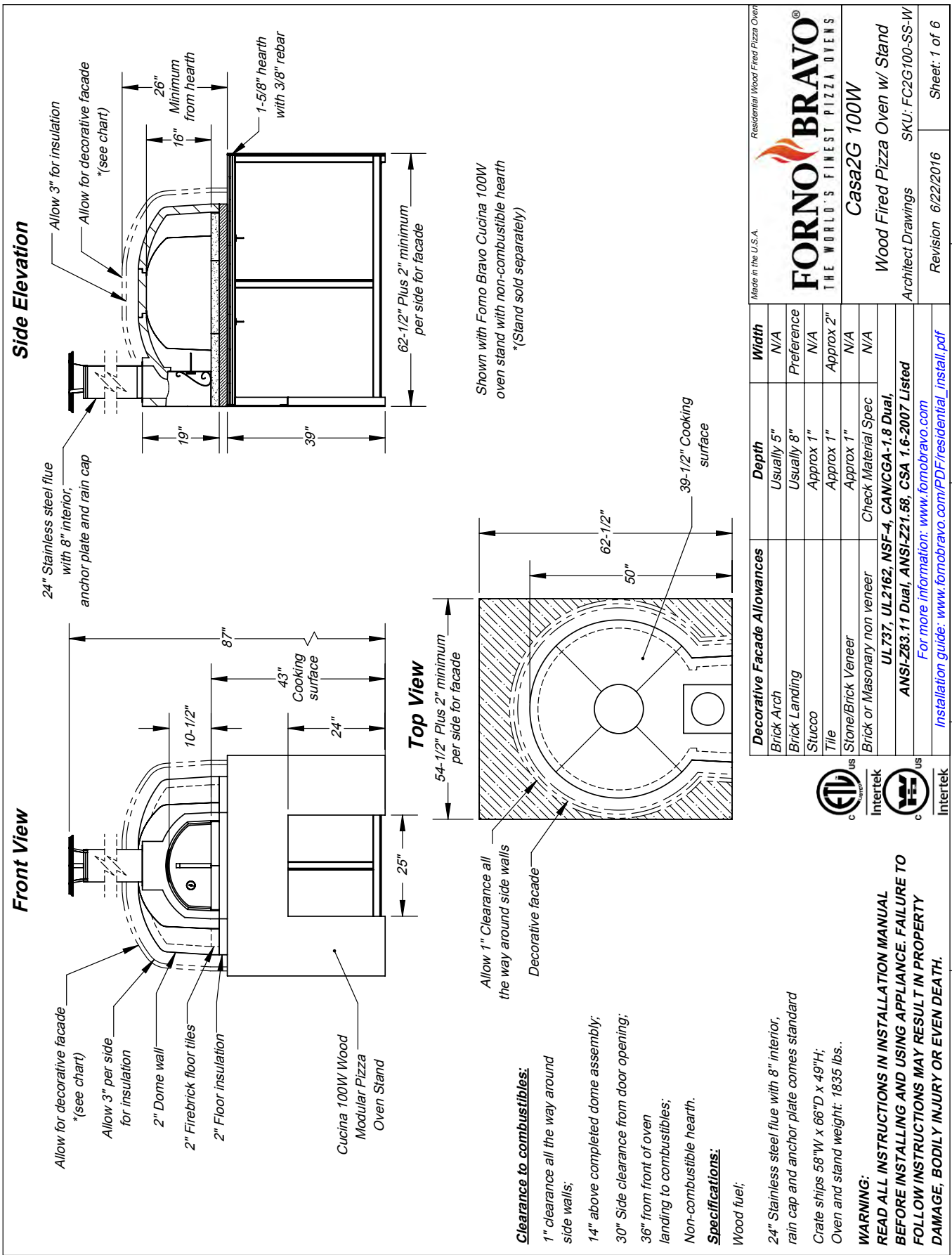

24" Stainless steel flue with 8" interior, anchor plate and rain cap

Allow for decorative facade *(see chart)

Allow 3" per side for insulation

2" Dome wall

2" Firebrick floor tiles

2" Floor insulation

8"

10-1/2"

43" Cooking surface

24"

19"

39"

62-1/2" Plus 2" minimum per side for facade

1-5/8" hearth with 3/8" rebar

25"

Cucina 100W Wood Modular Pizza Oven Stand

54-1/2" Plus 2" minimum per side for facade

50"

62-1/2"

39-1/2" Cooking surface

Allow 1" Clearance all the way around side walls

Decorative facade

Allow 3" for insulation *(see chart)

Minimum from hearth

Allow for decorative facade *(see chart)

Side Elevation

Shown with Forno Bravo Cucina 100W oven stand with non-combustible hearth *(Stand sold separately)

Clearance to combustibles:

1" clearance all the way around side walls;

14" above completed dome assembly;

30" Side clearance from door opening;

36" from front of oven landing to combustibles;

Non-combustible hearth.

Specifications:

Wood fuel;

24" Stainless steel flue with 8" interior, rain cap and anchor plate comes standard

Crate ships 58"W x 66"D x 49"H;

Oven and stand weight: 1835 lbs..

WARNING:

READ ALL INSTRUCTIONS IN INSTALLATION MANUAL BEFORE INSTALLING AND USING APPLIANCE. FAILURE TO FOLLOW INSTRUCTIONS MAY RESULT IN PROPERTY DAMAGE, BODILY INJURY OR EVEN DEATH.

Made in the U.S.A.		Residential Wood Fired Pizza Oven	
FORNO BRAVO® THE WORLD'S FINEST PIZZA OVENS		Casa2G 100W	
Wood Fired Pizza Oven w/ Stand		SKU: FC2G100-SS-W	
Architect Drawings		Revision 6/22/2016	
Revision 6/22/2016		Sheet: 1 of 6	
Decorative Facade Allowances	Depth	Width	
Brick Arch	Usually 5"	N/A	
Brick Landing	Usually 8"	Preference	
Stucco	Approx 1"	N/A	
Tile	Approx 1"	Approx 2"	
Stone/Brick Veneer	Approx 1"	N/A	
Brick or Masonry non veneer	Check Material Spec	N/A	
UL 737, UL2162, NSF-4, CAN/CGA-1.8 Dual, ANSI-Z83.11 Dual, ANSI-Z21.58, CSA 1.6-2007 Listed			
For more information: www.fornobravo.com			
Installation guide: www.fornobravo.com/PDF/residential_install.pdf			



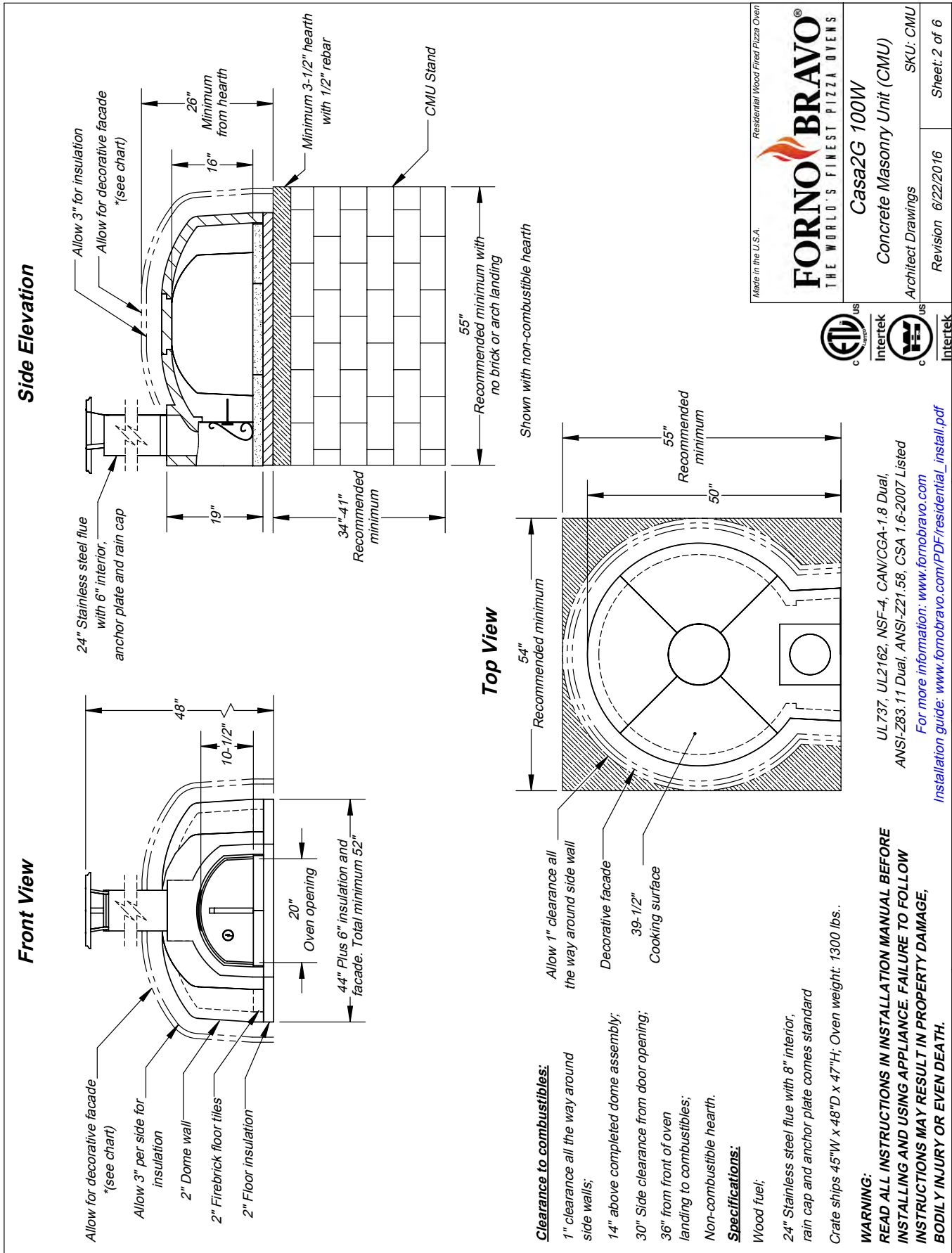

Made in the U.S.A.

FORNO BRAVO
 THE WORLD'S FINEST PIZZA OVENS

Residential Wood Fired Pizza Oven

Casa2G 100W

Concrete Masonry Unit (CMU)

Architect Drawings SKU: CMU

Revision 6/22/2016 Sheet: 2 of 6



1 2 3 4 5

ISO View

3/8" Rebar
 Steel reinforced hearth requires 1-5/8" thick concrete pad with 3/8" rebar. Do not use vermiculite in concrete mix on this pad with Cucina stand. *(Not included. See installation guide)

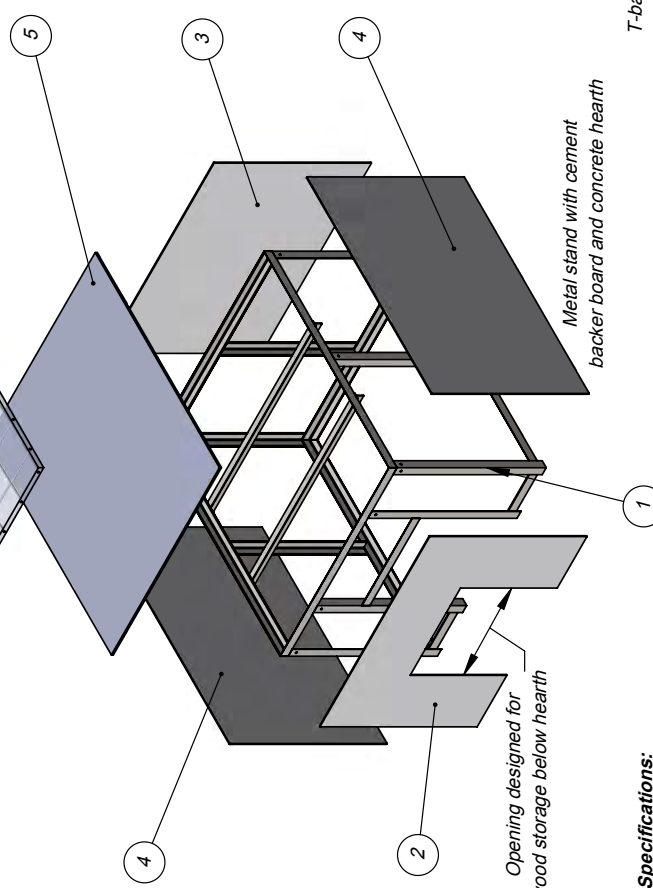

Opening designed for wood storage below hearth
 Metal stand with cement backer board and concrete hearth

Specifications:

Stand includes metal frame, assembly hardware, pre-cut / pre-filled exterior cement backer board panels.

The Cucina 100W stand works with Casa2G 100W oven.

* Hearth materials not included. See installation guide.

WARNING:
 READ ALL INSTRUCTIONS IN INSTALLATION MANUAL BEFORE INSTALLING AND USING APPLIANCE. FAILURE TO FOLLOW INSTRUCTIONS MAY RESULT IN PROPERTY DAMAGE, BODILY INJURY OR EVEN DEATH.

For more information: www.fornobravo.com
 Installation guide: www.fornobravo.com/PDF/residential_install.pdf



Front View

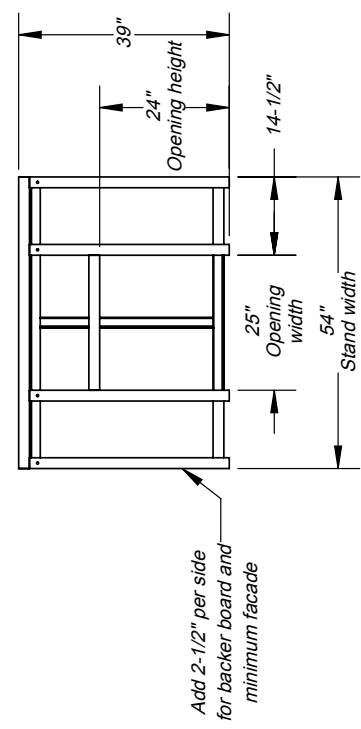

Side Elevation

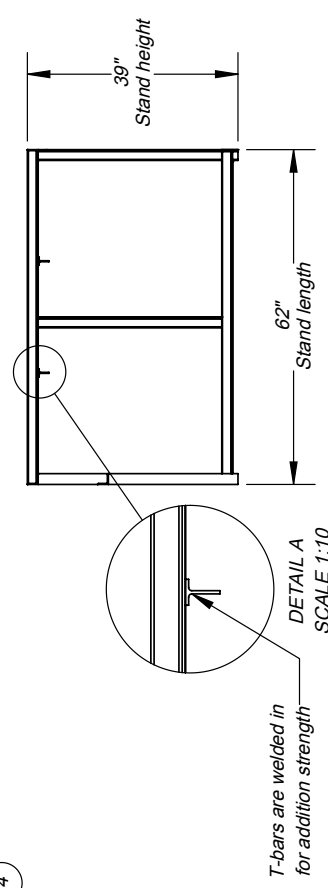

DETAIL A
 SCALE 1:10

ITEM#	PART NAME	DESCRIPTION	QTY
1	Cucina2G 100W	Metal frame substructure	1
2	Front Panel	1/4" Pre-cut Backer Board	1
3	Back Panel	1/4" Pre-cut Backer Board	1
4	Side Panel	1/4" Pre-cut Backer Board	2
5	Top Panel	1/2" Pre-cut Backer Board	1
6	Hex Bolt, 3/8" x 1"	*Not displayed	10
7	Hex Nut, 3/8"	*Not displayed	10
8	Self Tapping Screw	*Not displayed	55
	Concrete Hearth	* See installation guide	
	Rebar	* See installation guide	

Made in the U.S.A.
 Residential Wood Fired Pizza Oven
FORNO BRAVO®
 THE WORLD'S FINEST PIZZA OVENS
Cucina 100W
 Wood Fired Pizza Oven Stand
 Architect Drawings SKU: ICS100W
 Revision 6/22/2016 Sheet: 3 of 6

ISO View

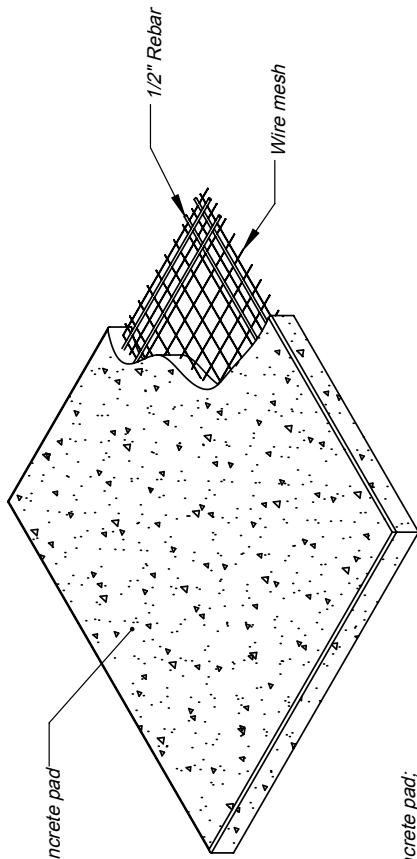

Top View

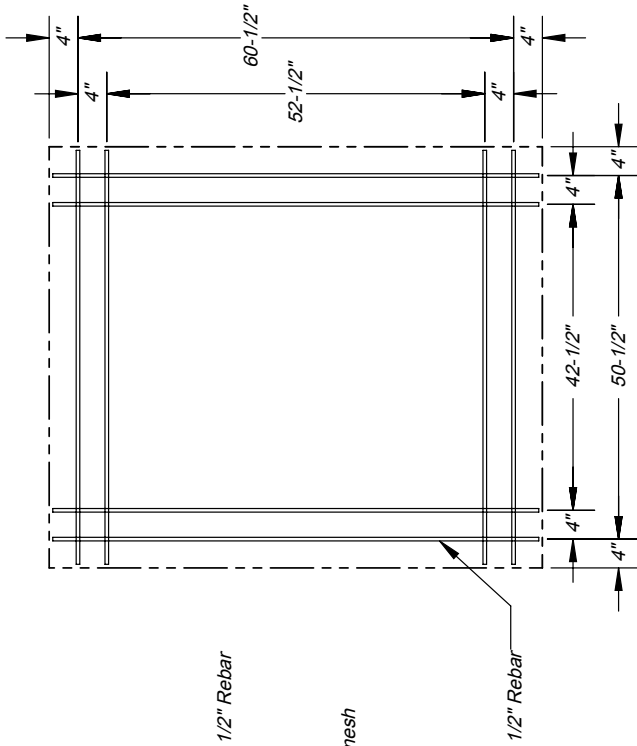

Side Elevation

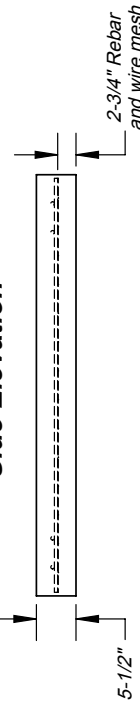

Casa2G 100W oven stand footprint
(*See specifications for CMU stand)

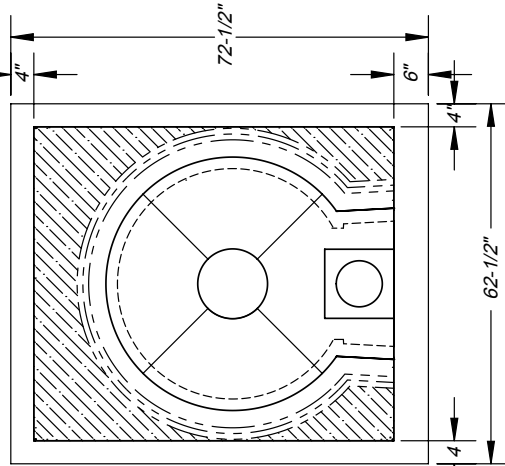

Specifications:

Minimum 5-1/2" deep concrete pad;

Reinforced with 1/2" rebar and wire mesh. * wire mesh is not shown in some views for print clarity;

Cut rebar and wire mesh short to conceal inside concrete pad;

*CMU stand requires a minimum cement foundation pad of 62"W x 65"D

Slab dimensions:

Minimum 8" wider than oven stand and hearth;

Minimum 10" deeper than oven stand and hearth;

Finished slab should be 2" to 3" above ground level;

Refer to local building codes for recommendations regarding soil compaction, frost line and other considerations. Depending on local conditions, you may have to excavate down 18" or more of topsoil to reach stable substrate.

WARNING:
READ ALL INSTRUCTIONS IN INSTALLATION MANUAL BEFORE INSTALLING AND USING APPLIANCE. FAILURE TO FOLLOW INSTRUCTIONS MAY RESULT IN PROPERTY DAMAGE, BODILY INJURY OR EVEN DEATH.

Made in the U.S.A.

Residential Wood Fired Pizza Oven

Casa2G 100W
Wood Fired Pizza Oven Pad

Architect Drawings

Revision 6/22/2016

Sheet: 4 of 6

For more information: www.fornobravo.com
Installation guide: www.fornobravo.com/PDF/residential_install.pdf

Side Elevation

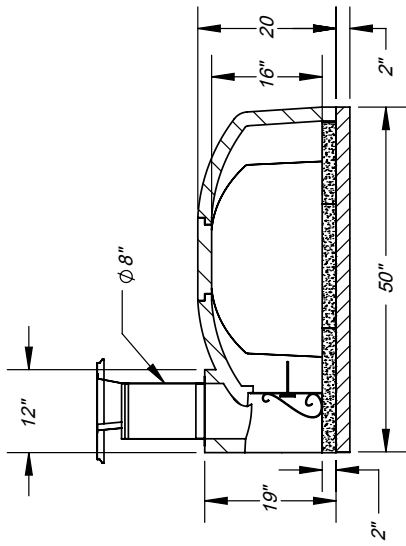

SECTION A-A
 SCALE 1 : 25

Front View

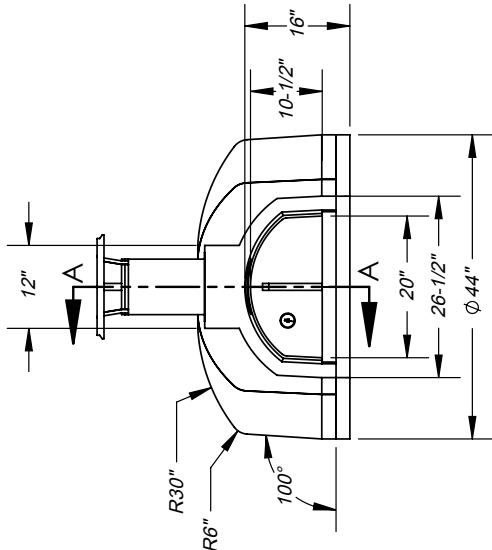

Top View

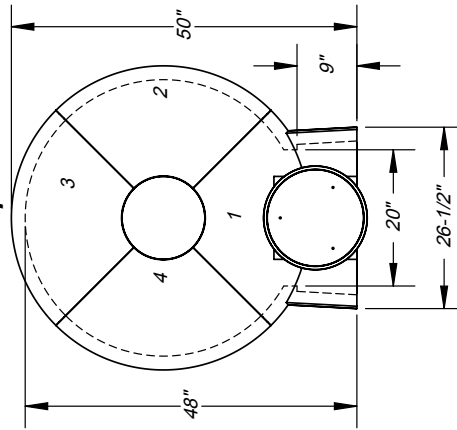

Casa2G 100W Pizza Oven Kit includes:

- Commercial grade refractory oven dome with integral vent
- 2" ceramic fiber insulation board
- 3" ceramic fiber insulation blanket (multiple 1" thick blankets)
- NSF-4 rated fireclay cooking surface
- High temp refractory mortar to seal dome joints
- Single wall stove pipe, anchor plate, 24" pipe and cap
- Single wall steel powder coated door
- Door thermometer

Sold separately:

- UL certified spark arrestor
- Decorative brick arch
- Double wall insulated steel door to retain heat longer
- Cucina stand with steel frame and handle-backer board precut
- Stove pipe extensions
- Upgrade to double wall chimney for indoor installations / covered patios
- Pizza Oven Tools, infrared thermometer, gloves and other items

To be provided by customer / contractor:

- Concrete support pad with rebar (or equivalent structure)
- Concrete masonry stand (CMU) or equivalent non-combustible structure
- Decorative facade materials (stucco, brick, tile, steel, etc.)

Certifications:

Tested and compliant with:
 UL737, UL2162, NSF-4, CAN/CGA-1.8 Dual, ANSI-Z83.11 Dual, ANSI-Z21.58-CSA 1.6-2007
 For more information about our certifications, click here: www.fornobravo.com/ul-certified

WARNING:

READ ALL INSTRUCTIONS IN INSTALLATION MANUAL BEFORE INSTALLING AND USING APPLIANCE. FAILURE TO FOLLOW INSTRUCTIONS MAY RESULT IN PROPERTY DAMAGE, BODILY INJURY OR EVEN DEATH
 Installation manual can be found by clicking on this link: www.fornobravo.com/PDF/residential_install.pdf

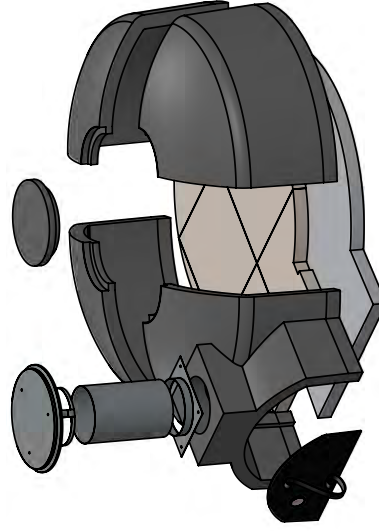

Made in the U.S.A. Residential Wood Fired Pizza Oven

FORNO BRAVO®
 THE WORLD'S FINEST PIZZA OVENS

Casa2G 100W
 Wood Fired Pizza Oven
 Architect Drawings

Revision 6/22/2016 Sheet: 5 of 6



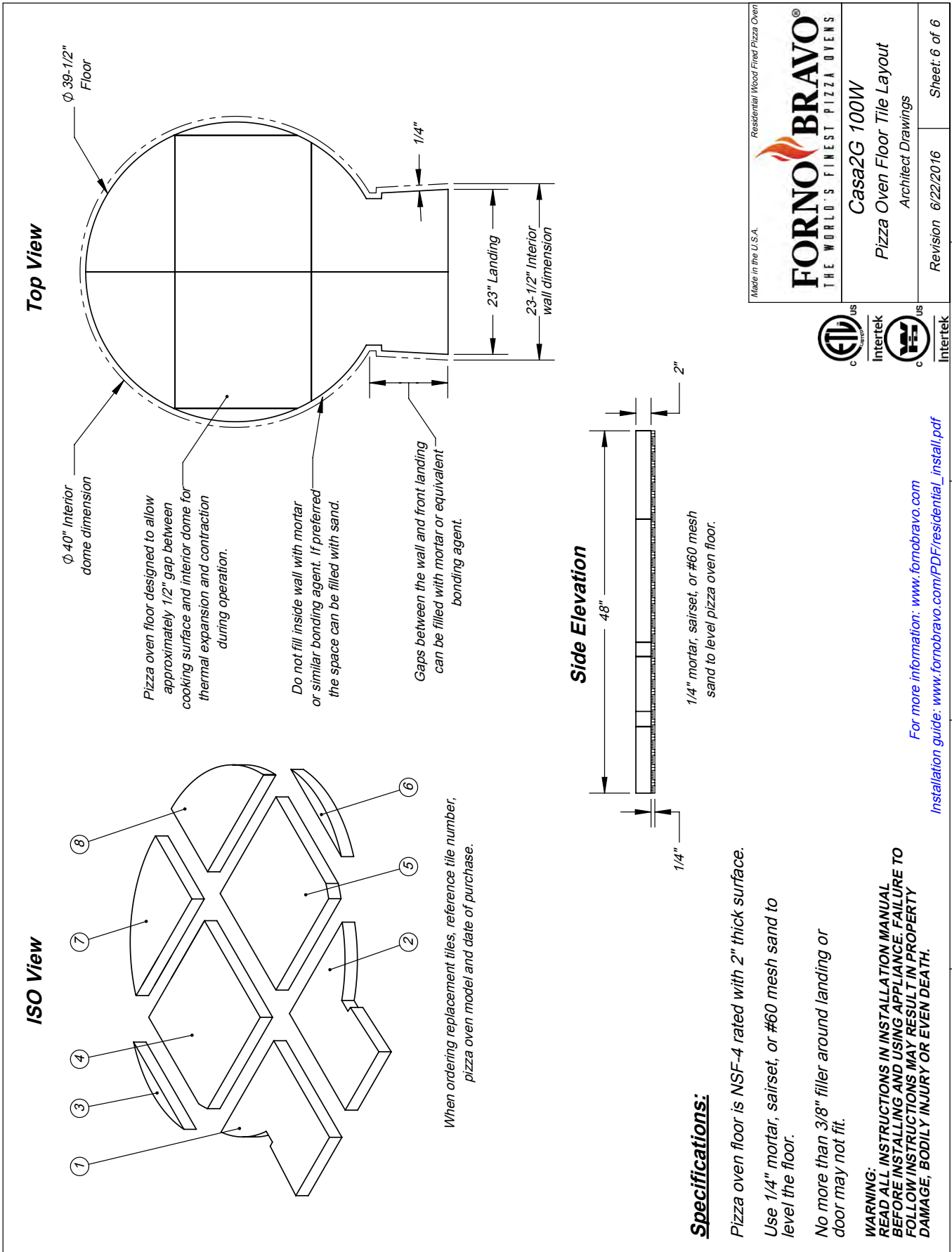

Made in the U.S.A.

FORNO BRAVO
 THE WORLD'S FINEST PIZZA OVENS

Casa2G 100W

Pizza Oven Floor Tile Layout

Architect Drawings

Revision 6/22/2016

Sheet: 6 of 6



For more information: www.fornobravo.com
 Installation guide: www.fornobravo.com/PDF/residential_install.pdf

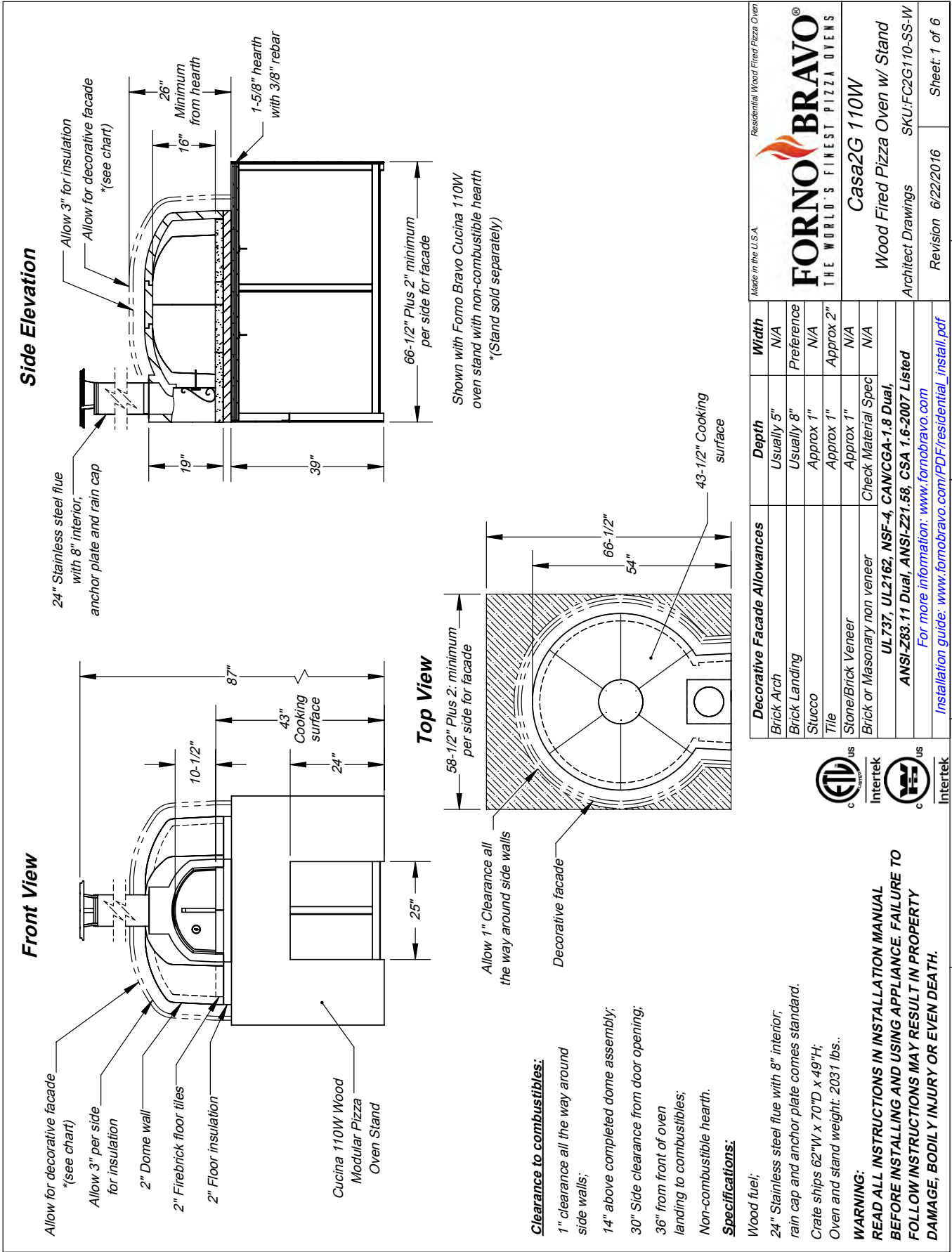

Clearance to combustibles:

- 1" clearance all the way around side walls;
- 14" above completed dome assembly;
- 30" Side clearance from door opening;
- 36" from front of oven landing to combustibles;
- Non-combustible hearth.

Specifications:

- Wood fuel;
- 24" Stainless steel flue with 8" interior, rain cap and anchor plate comes standard.
- Crate ships 62"W x 70"D x 49"H;
- Oven and stand weight: 2031 lbs..

WARNING:
READ ALL INSTRUCTIONS IN INSTALLATION MANUAL BEFORE INSTALLING AND USING APPLIANCE. FAILURE TO FOLLOW INSTRUCTIONS MAY RESULT IN PROPERTY DAMAGE, BODILY INJURY OR EVEN DEATH.

Made in the U.S.A.		Residential Wood Fired Pizza Oven	
FORNO BRAVO® THE WORLD'S FINEST PIZZA OVENS		Casa2G 110W	
Wood Fired Pizza Oven w/ Stand		Architect Drawings	
Revision 6/22/2016		SKU:FC2G110-SS-W	
Revision 6/22/2016		Sheet: 1 of 6	
Decorative Facade Allowances	Depth	Width	
Brick Arch	Usually 5"	N/A	
Brick Landing	Usually 8"	Preference	
Stucco	Approx 1"	N/A	
Tile	Approx 1"	Approx 2"	
Stone/Brick Veneer	Approx 1"	N/A	
Brick or Masonry non veneer	Check Material Spec	N/A	
UL737, UL2162, NSF-4, CAN/CGA-1.8 Dual, ANSI-Z83.11 Dual, ANSI-Z21.58, CSA 1.6-2007 Listed			
For more information: www.fornobravo.com			
Installation guide: www.fornobravo.com/PDF/residential_install.pdf			



Front View

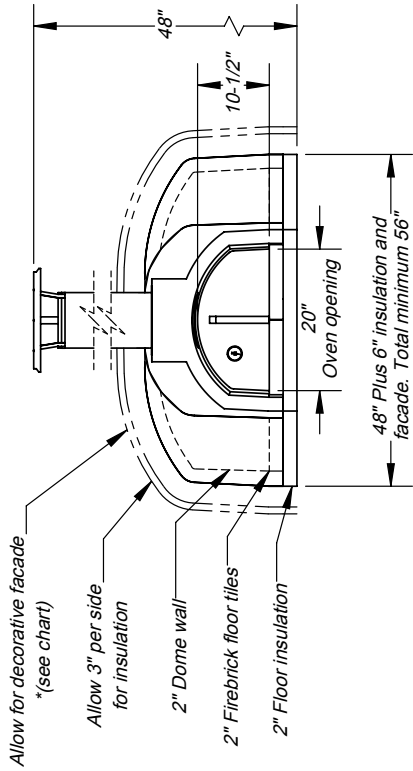

Side Elevation

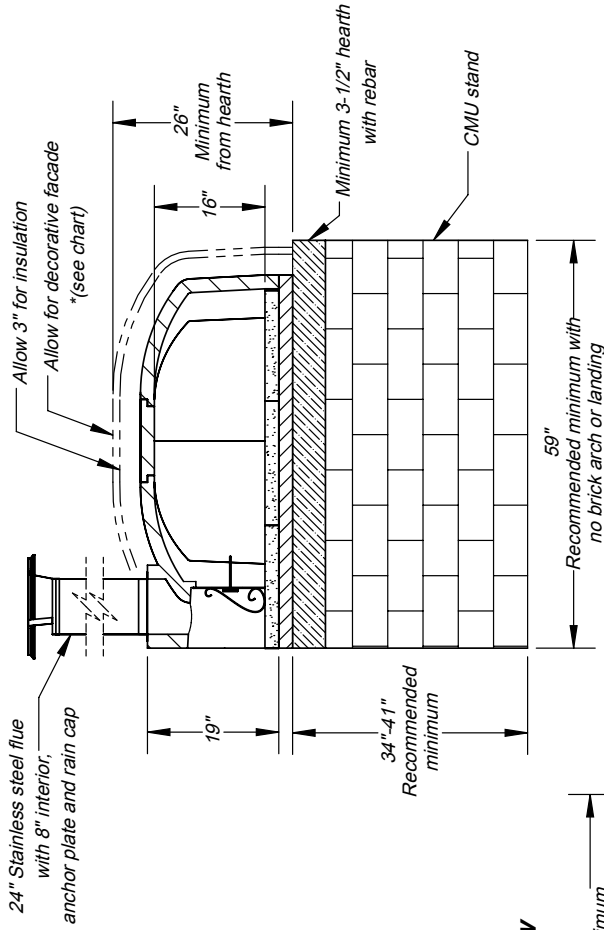

Top View

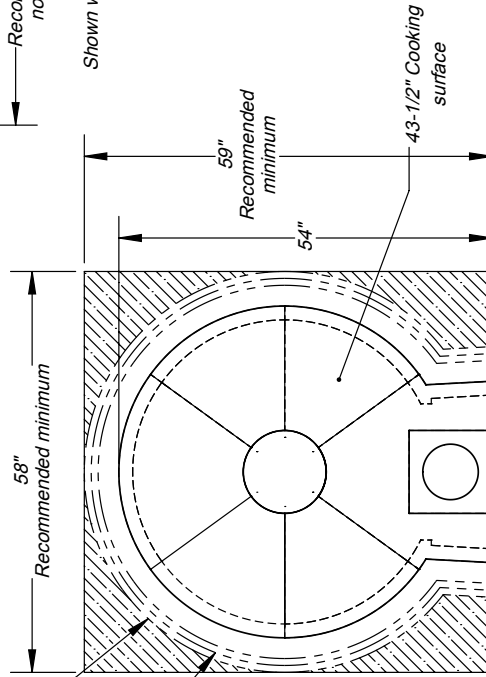

Allow 1" Clearance all the way around side walls

Clearance to combustibles:

- 1" clearance all the way around side walls;
- 14" above completed dome assembly;
- 30" Side clearance from door opening;
- 36" from front of oven landing to combustibles;
- Non-combustible hearth.

Specifications:

- Wood fuel;
- 24" Stainless steel flue with 8" interior; rain cap and anchor plate comes standard.
- Crate ships 45"W x 51"D x 47"H;
- Oven weight: 1496 lbs..

WARNING:

READ ALL INSTRUCTIONS IN INSTALLATION MANUAL BEFORE INSTALLING AND USING APPLIANCE. FAILURE TO FOLLOW INSTRUCTIONS MAY RESULT IN PROPERTY DAMAGE, BODILY INJURY OR EVEN DEATH.

Made in the U.S.A.

Residential Wood Fired Pizza Oven

Casa2G 110W

Concrete Masonry Unit (CMU)

Architect Drawings

Revision 6/22/2016

SKU: CMU

Sheet: 2 of 6



UL737, UL2162, NSF-4, CAM/CGA-1.8 Dual, ANSI-Z83.11 Dual, ANSI-Z21.58, CSA 1.6-2007 Listed

For more information: www.fornobravo.com

Installation guide: www.fornobravo.com/PDF/residential_install.pdf

ISO View

Steel reinforced hearth requires 1-5/8" thick concrete pad with 3/8" rebar. Do not use vermiculite in concrete mix on this pad with Cucina stand. *(Not included. See installation guide)

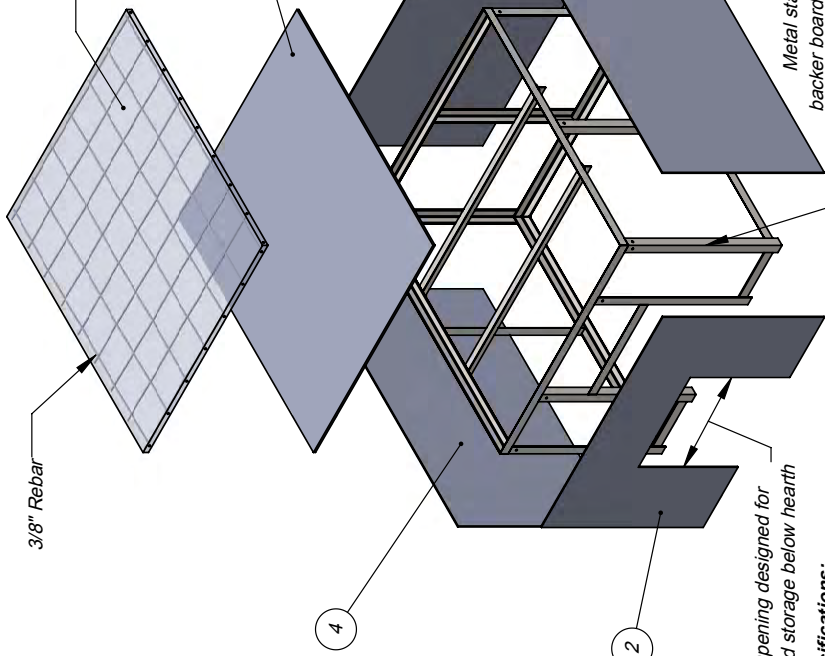

Opening designed for wood storage below hearth
Specifications:
 Stand includes metal frame, assembly hardware, pre-cut / predrilled exterior cement backer board panels.

The Cucina 110W stand works with Casa2G 110W and Premio2G 100W ovens.

* Hearth materials not included. See installation guide.

WARNING:
 READ ALL INSTRUCTIONS ON INSTALLATION MANUAL BEFORE INSTALLING AND USING APPLIANCE. FAILURE TO FOLLOW INSTRUCTIONS MAY RESULT IN PROPERTY DAMAGE, BODILY INJURY OR EVEN DEATH.

For more information: www.fornobravo.com
 Installation guide: www.fornobravo.com/PDF/residential_install.pdf



Front View

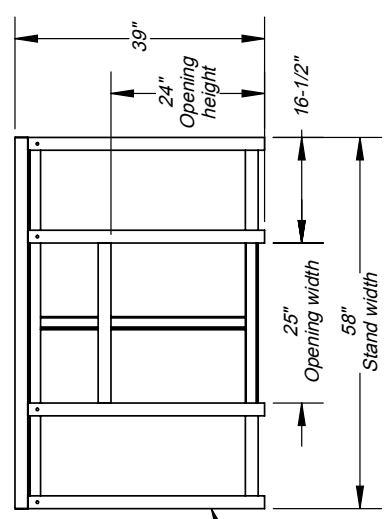

Side Elevation

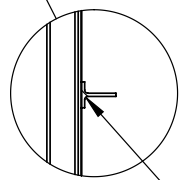
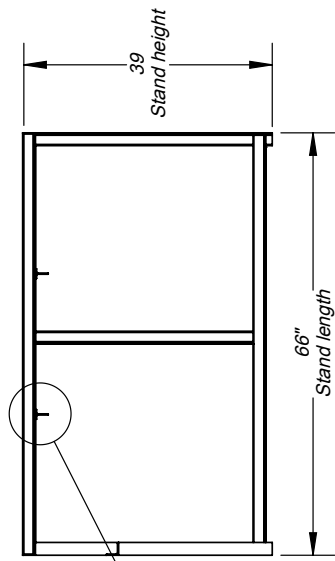

DETAIL A
 SCALE 1 : 10

ITEM#	PART NAME	DESCRIPTION	QTY
1	Cucina2G 110W	Metal frame substructure	1
2	Front Panel	1/4" Pre-cut Backer Board	1
3	Back Panel	1/4" Pre-cut Backer Board	1
4	Side Panel	1/4" Pre-cut Backer Board	2
5	Top Panel	1/2" Pre-cut Backer Board	1
6	Hex Bolt, 3/8" x 1"	*Not displayed	10
7	Hex Nut, 3/8"	*Not displayed	10
8	Self Tapping Screw	*Not displayed	55
	*Concrete Hearth	* See installation guide	
	*Rebar	* See installation guide	

Made in the U.S.A.
FORNO BRAVO®
 THE WORLD'S FINEST PIZZA OVENS
 Residential Wood Fired Pizza Oven
Cucina 110W
 Gas Fired Pizza Oven Stand
 Architect Drawings SKU: ICS110W
 Revision 6/22/2016 Sheet: 3 of 6

ISO View

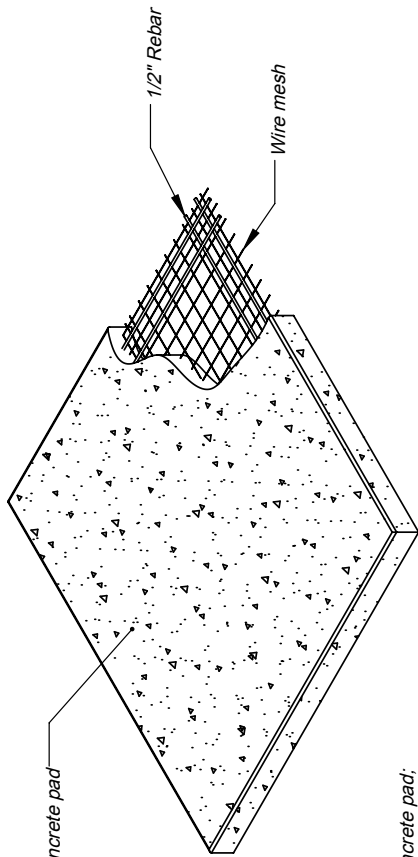

Top View

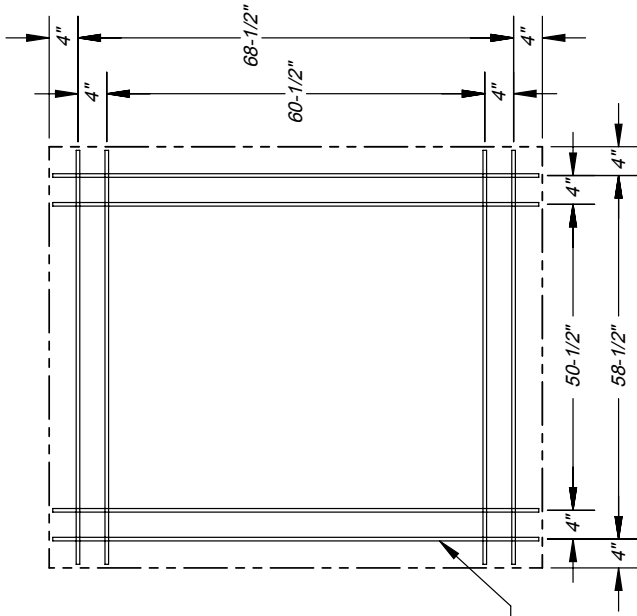

Side Elevation

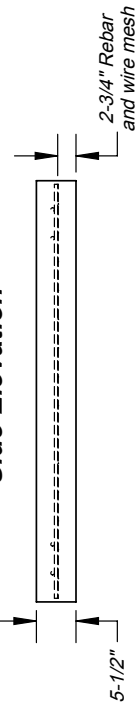

Casa2G 110W oven stand footprint
(*See specifications for CMU stand)

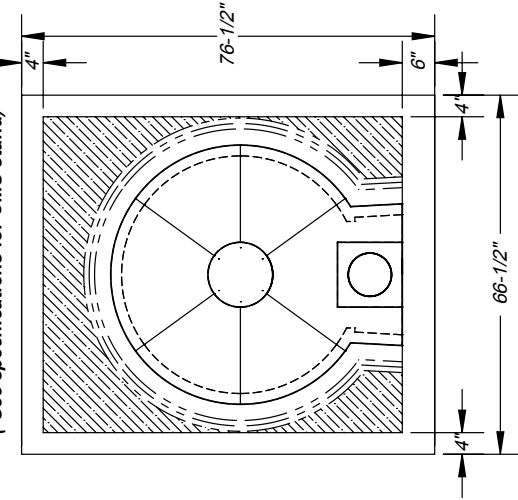

5-1/2" Reinforced concrete pad

1/2" Rebar

Wire mesh

1/2" Rebar

Specifications:

Minimum 5-1/2" deep concrete pad;

Reinforced with 1/2" rebar and wire mesh. * wire mesh is not shown in some views for print clarity;

Cut rebar and wire mesh short to conceal inside concrete pad;

*CMU stand requires a minimum cement foundation pad of 66"W x 69"D

Slab dimensions:

Minimum 8" wider than oven stand and hearth;

Minimum 10" deeper than oven stand and hearth;

Finished slab should be 2" to 3" above ground level;

Refer to local building codes for recommendations regarding soil compaction, frost line and other considerations. Depending on local conditions, you may have to excavate down 18" or more of topsoil to reach stable substrate.

WARNING:
READ ALL INSTRUCTIONS IN INSTALLATION MANUAL BEFORE INSTALLING AND USING APPLIANCE. FAILURE TO FOLLOW INSTRUCTIONS MAY RESULT IN PROPERTY DAMAGE, BODILY INJURY OR EVEN DEATH.



Made in the U.S.A.

Residential Wood Fired Pizza Oven



Casa2G 110W
Wood Fired Pizza Oven Pad
Architect Drawings
Revision 6/22/2016
Sheet: 4 of 6

For more information: www.fornobravo.com
Installation guide: www.fornobravo.com/PDF/residential_install.pdf

Side Elevation

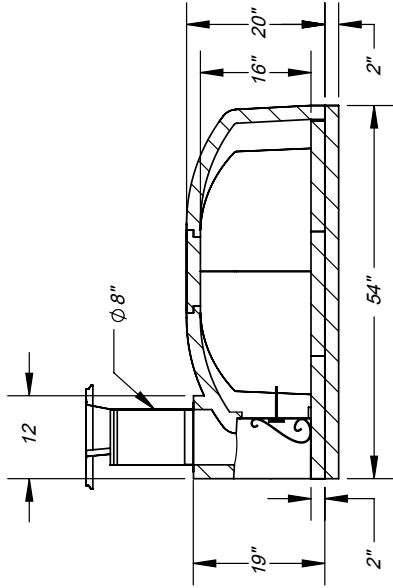

SECTION A-A
SCALE 1 : 25

Front View

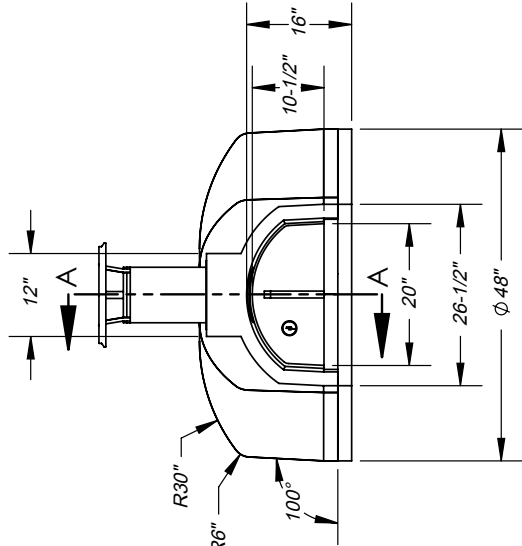

Casa2G 110W Pizza Oven Kit includes:

- Commercial grade refractory oven dome with integral vent
- 2" ceramic fiber insulation board
- 3" ceramic fiber insulation blanket (multiple 1" thick blankets)
- NSF-4 rated fireclay cooking surface
- High temp refractory mortar to seal dome joints
- Single wall stove pipe, anchor plate, 24" pipe and cap
- Single wall steel powder coated door
- Door thermometer

Sold separately:

- UL certified spark arrester
- Decorative brick arch
- Double wall insulated steel door to retain heat longer
- Cucina stand with steel frame and handle-backer board precut
- Stove pipe extensions
- Upgrade to double wall chimney for indoor installations / covered patios
- Pizza Oven Tools, infrared thermometer, gloves and other items

To be provided by customer / contractor:

- Concrete support pad with rebar (or equivalent structure)
- Concrete masonry stand (CMU) or equivalent non-combustible structure
- Decorative facade materials (stucco, brick, tile, steel, etc.)

Certifications:

Tested and compliant with:
 UL737, UL2162, NSF-4, CAN/CGA-1.8 Dual, ANSI-Z83.11 Dual, ANSI-Z221.58-CSA 1.6-2007
 For more information about our certifications, click here: www.fornobravo.com/ul-certified

WARNING:

READ ALL INSTRUCTIONS IN INSTALLATION MANUAL BEFORE INSTALLING AND USING APPLIANCE.
FAILURE TO FOLLOW INSTRUCTIONS MAY RESULT IN PROPERTY DAMAGE, BODILY INJURY OR EVEN DEATH
 Installation manual can be found by clicking on this link: www.fornobravo.com/PDF/residential_install.pdf

Top View

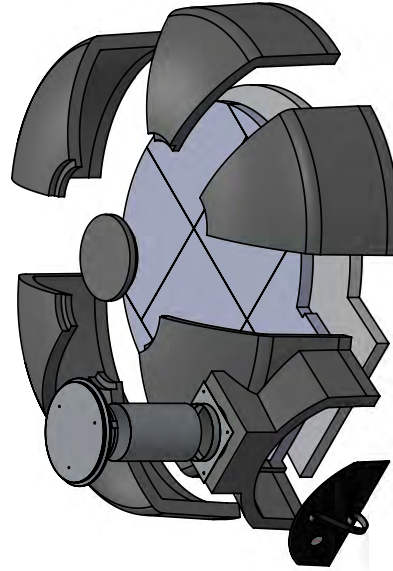
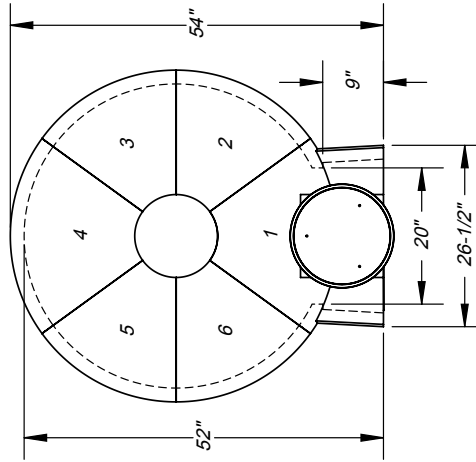

Made in the U.S.A. Residential Wood Fired Pizza Oven

FORNO BRAVO®
 THE WORLD'S FINEST PIZZA OVENS

Casa2G 110W
 Wood Fired Pizza Oven
 Architect Drawings

Revision 6/22/2016 Sheet: 5 of 6

ETL Intertek
 Intertek Intertek

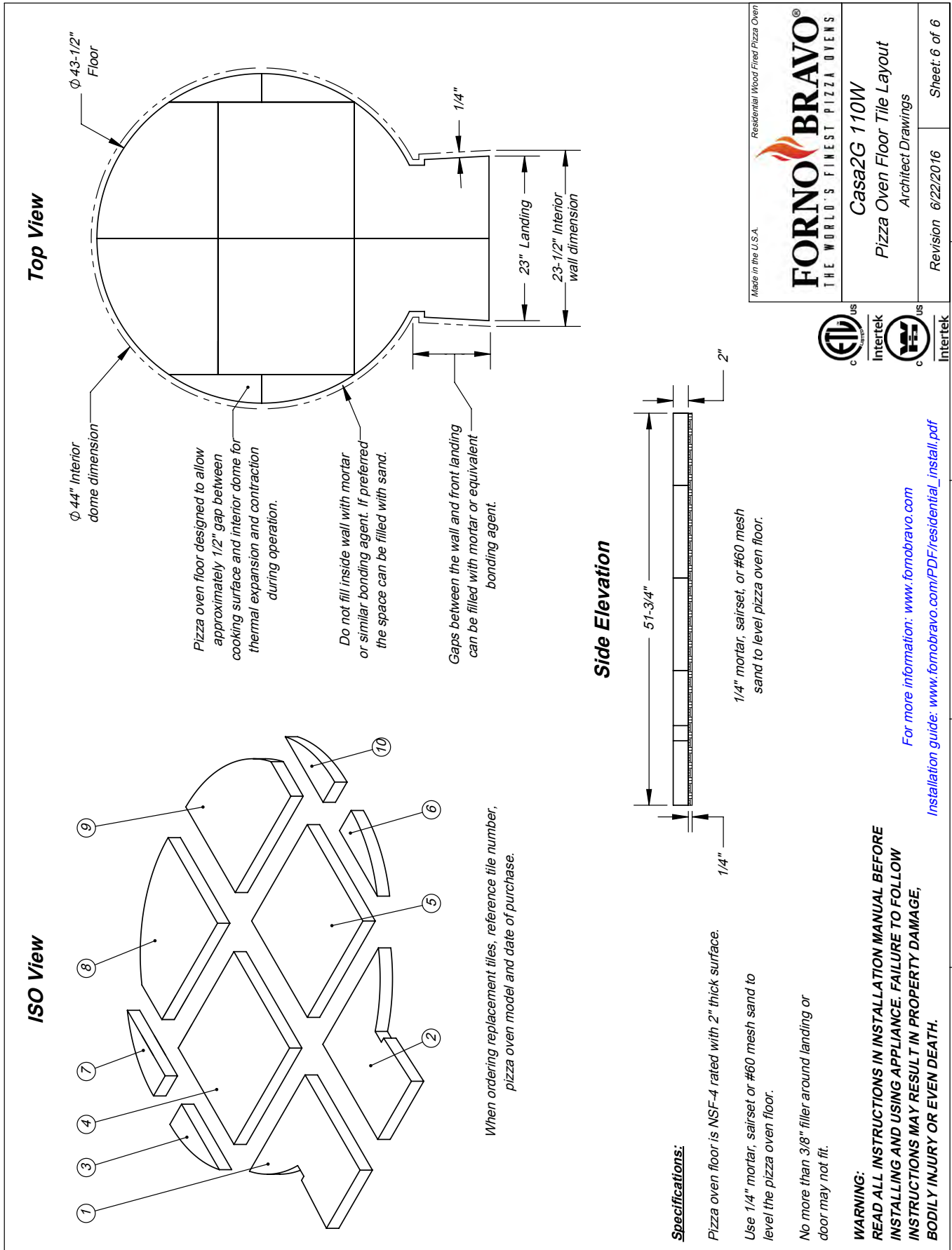

Made in the U.S.A.

FORNO BRAVO
 THE WORLD'S FINEST PIZZA OVENS

Residential Wood Fired Pizza Oven

Casa2G 110W

Pizza Oven Floor Tile Layout

Architect Drawings

Revision 6/22/2016

Sheet: 6 of 6

ETL Intertek

1 2 3 4 5

Front View

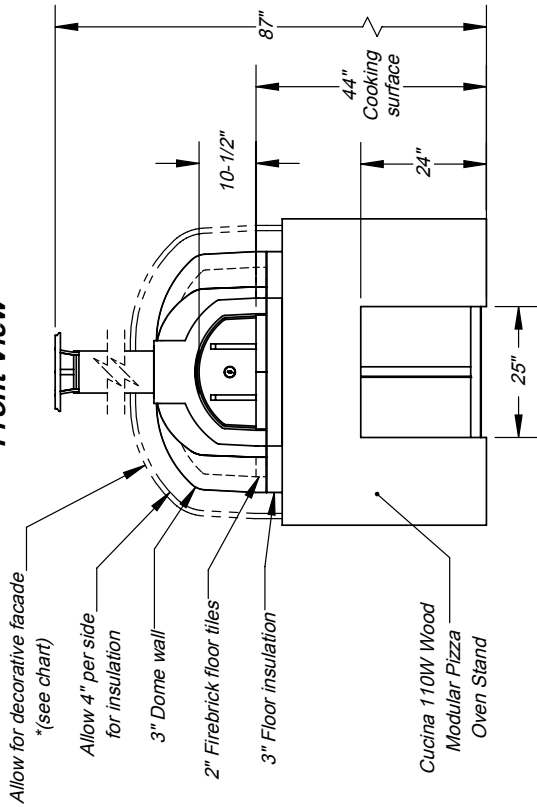

Side Elevation

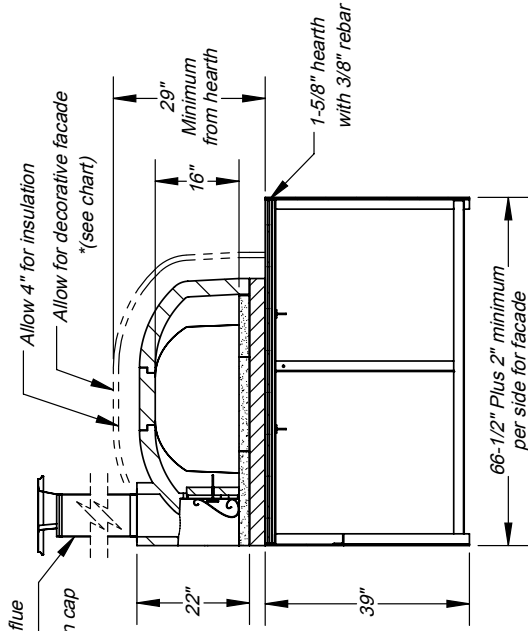

Top View

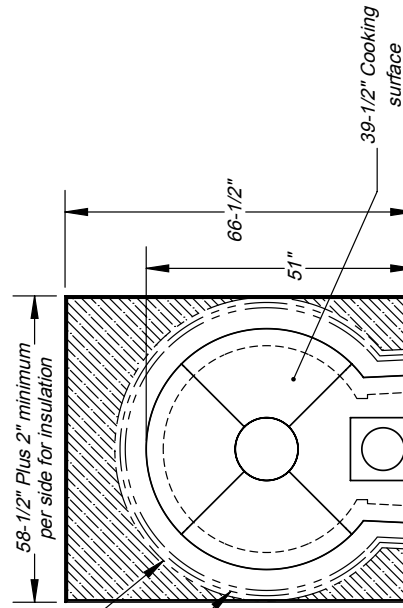

Shown with Forno Bravo Cucina 110W oven stand with non-combustible hearth
*(Stand sold separately)

Clearance to combustibles:

- 1" clearance all the way around side walls;
- 14" above completed dome assembly;
- 30" Side clearance from door opening;
- 36" from front of oven landing to combustibles;
- Non-combustible hearth.

Specifications:

- Wood fuel;
- 24" Stainless steel flue with 8" interior; rain cap and anchor plate comes standard;
- Crate ships 62"W x 70"D x 49"H;
- Oven and stand weight: 2031 lbs..

WARNING:

READ ALL INSTRUCTIONS IN INSTALLATION MANUAL BEFORE INSTALLING AND USING APPLIANCE. FAILURE TO FOLLOW INSTRUCTIONS MAY RESULT IN PROPERTY DAMAGE, BODILY INJURY OR EVEN DEATH.

Made in the U.S.A.		Residential Wood Fired Pizza Oven	
		Premio2G 100W	
		Wood Fired Pizza Oven w/ Stand	
Architect Drawings		SKU: FP2G100-SS-W	
Revision		6/22/2016	
Revision		1 of 6	
Decorative Facade Allowances	Depth	Width	
Brick Arch	Usually 5"	N/A	
Brick Landing	Usually 8"	Preference	
Stucco	Approx 1"	N/A	
Tile	Approx 1"	Approx 2"	
Stone/Brick Veneer	Approx 1"	N/A	
Brick or Masonry non veneer	Check Material Spec	N/A	
ANSI-Z21.58, CSA 1.6-2007 Listed UL737, UL2162, NSF-4, CAN/CGA-1.8, ANSI-Z83.11, For more information: www.fornobravo.com Installation guide: www.fornobravo.com/PDF/residential_install.pdf			



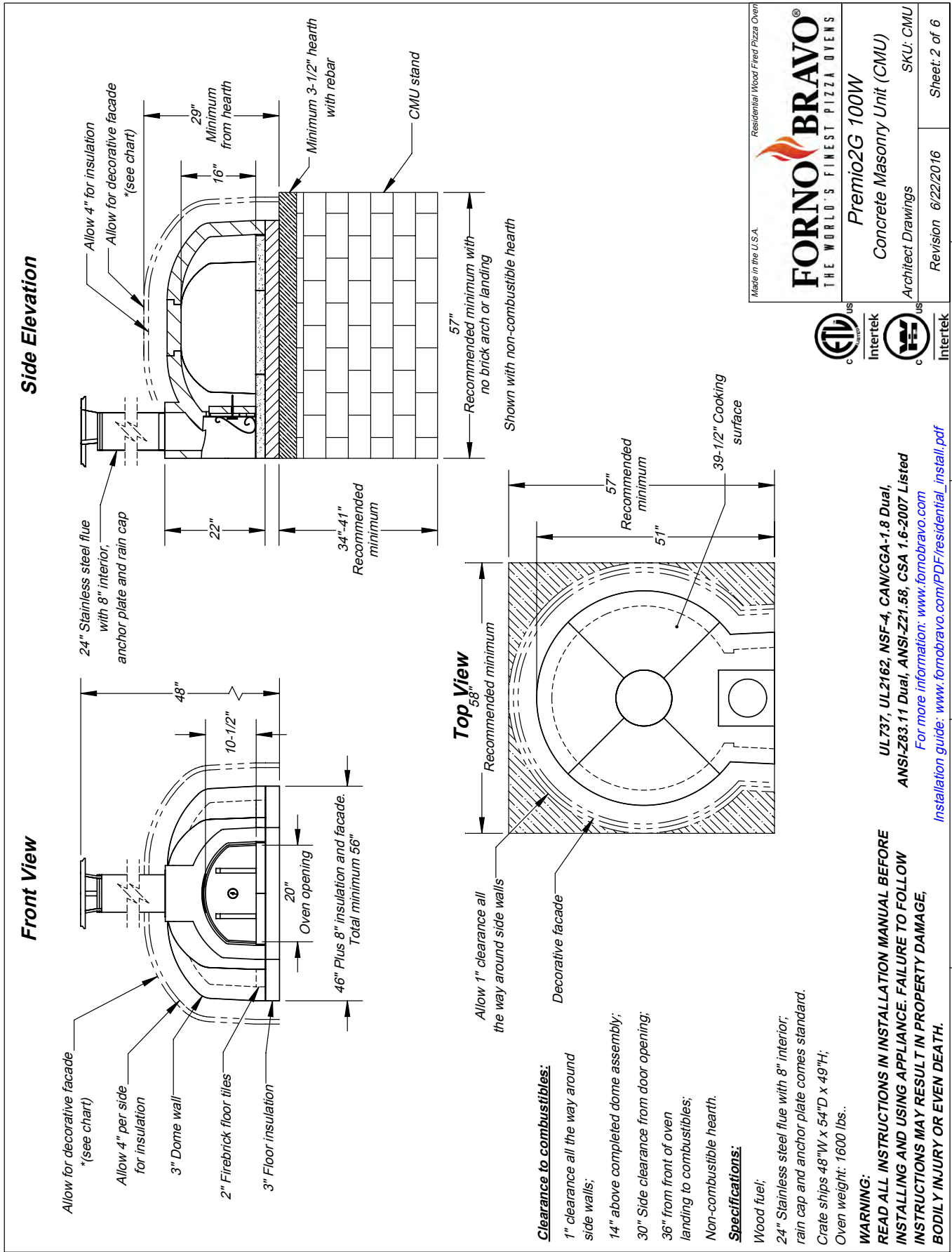

Made in the U.S.A.

FORNO BRAVO®
 THE WORLD'S FINEST PIZZA OVENS

Residential Wood Fired Pizza Oven

Premio2G 100W

Concrete Masonry Unit (CMU)

Architect Drawings

Revision 6/22/2016

SKU: CMU

Sheet: 2 of 6



UL737, UL2162, NSF-4, CAN/CGA-1.8 Dual,
 ANSI-Z83.11 Dual, ANSI-Z21.58, CSA 1.6-2007 Listed
 For more information: www.fornobravo.com
 Installation guide: www.fornobravo.com/PDF/residential_install.pdf

ISO View

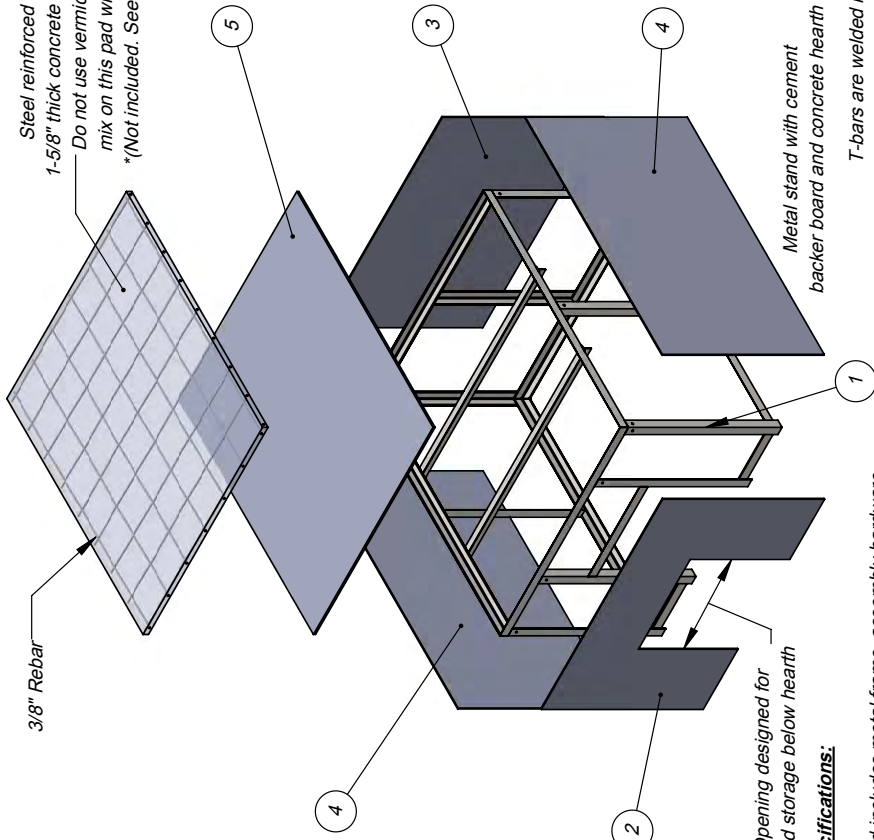

Opening designed for wood storage below hearth

Specifications:
Stand includes metal frame, assembly hardware, pre-cut / predrilled exterior cement backer board panels.

The Cucina 110W stand works with Premio2G 100W and Casa2G 110W ovens.

* Hearth materials not included. See installation guide.

WARNING:
READ ALL INSTRUCTIONS ON INSTALLATION MANUAL BEFORE INSTALLING AND USING APPLIANCE. FAILURE TO FOLLOW INSTRUCTIONS MAY RESULT IN PROPERTY DAMAGE, BODILY INJURY OR EVEN DEATH.

For more information: www.fornobravo.com
Installation guide: www.fornobravo.com/PDF/residential_install.pdf



Front View

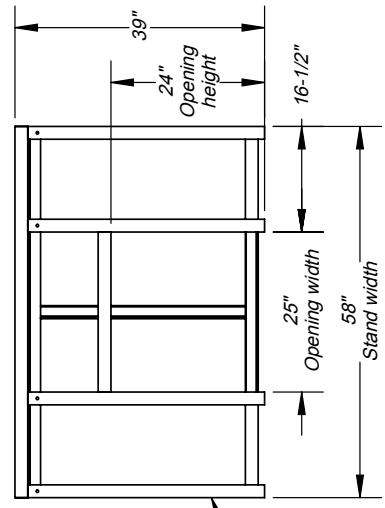

Side Elevation

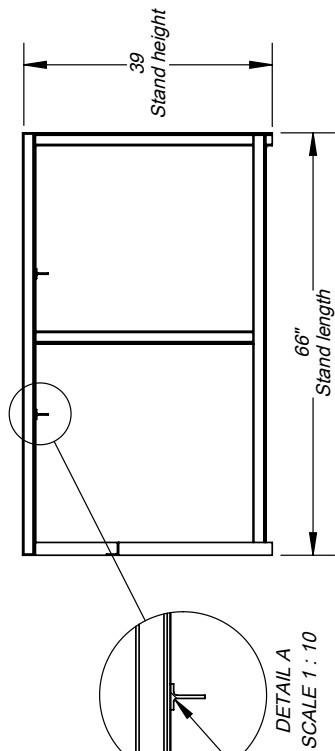

SCALE 1 : 10

ITEM#	PART NAME	DESCRIPTION	QTY
1	Cucina2G 110W	Metal frame substructure	1
2	Front Panel	1/4" Pre-cut Backer Board	1
3	Back Panel	1/4" Pre-cut Backer Board	1
4	Side Panel	1/4" Pre-cut Backer Board	2
5	Top Panel	1/2" Pre-cut Backer Board	1
6	Hex Bolt, 3/8" x 1"	*Not displayed	10
7	Hex Nut, 3/8"	*Not displayed	10
8	Self Tapping Screw	*Not displayed	55
	*Concrete Hearth	* See installation guide	
	*Rebar	* See installation guide	

Made in the U.S.A.

FORNO BRAVO®
THE WORLD'S FINEST PIZZA OVENS

Cucina 110W

Wood Fired Pizza Oven Stand

Architect Drawings SKU: ICS110W

Revision 6/22/2016 Sheet: 3 of 6

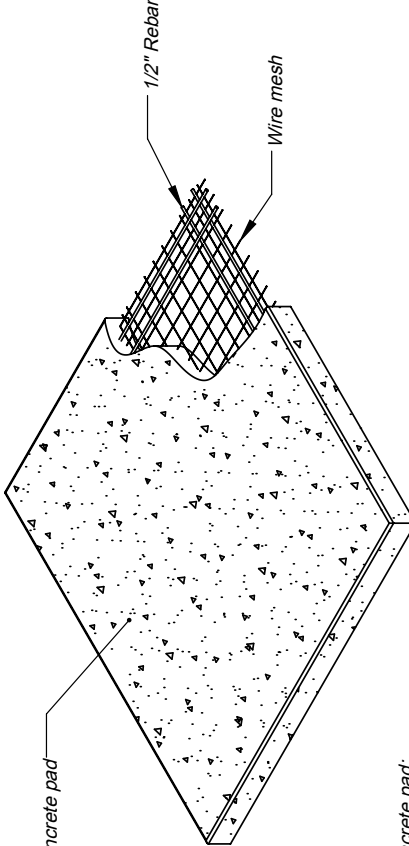

ISO View

5-1/2" Reinforced concrete pad

1/2" Rebar

Wire mesh

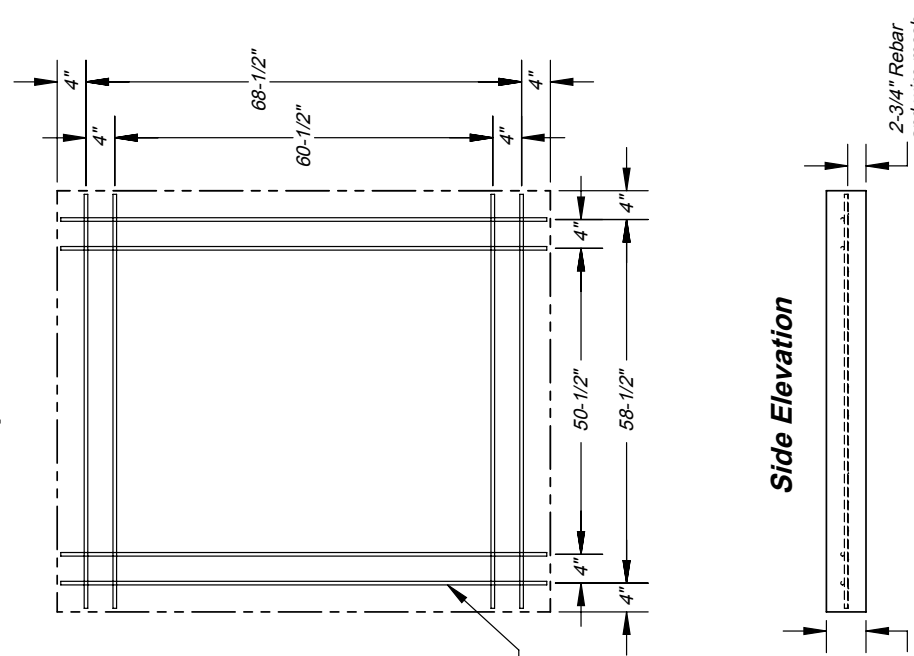

Top View

68-1/2"

60-1/2"

50-1/2"

58-1/2"

2-3/4" Rebar and wire mesh

Side Elevation

5-1/2"

76-1/2"

6"

66-1/2"

Premio2G 100W oven stand footprint (*See specifications for CMU stand)

Specifications:

- Minimum 5-1/2" deep concrete pad;
- Reinforced with 1/2" rebar and wire mesh. * wire mesh is not shown in some views for print clarity;
- Cut rebar and wire mesh short to conceal inside concrete pad;
- *CMU stand requires a minimum cement foundation pad of 58"W x 57"D



Slab dimensions:

- Minimum 8" wider than oven stand and hearth;
- Minimum 10" deeper than oven stand and hearth;
- Finished slab should be 2" to 3" above ground level;

Refer to local building codes for recommendations regarding soil compaction, frost line and other considerations. Depending on local conditions, you may have to excavate down 18" or more of topsoil to reach stable substrate.

WARNING:
READ ALL INSTRUCTIONS IN INSTALLATION MANUAL BEFORE INSTALLING AND USING APPLIANCE. FAILURE TO FOLLOW INSTRUCTIONS MAY RESULT IN PROPERTY DAMAGE, BODILY INJURY OR EVEN DEATH.

For more information: www.fornobravo.com
 Installation guide: www.fornobravo.com/PDF/residential_install.pdf





Residential Wood Fired Pizza Oven
FORNO BRAVO®
 THE WORLD'S FINEST PIZZA OVENS

Premio2G 100W
 Wood Fired Pizza Oven Pad
 Architect Drawings

Revision 6/22/2016 Sheet: 4 of 6

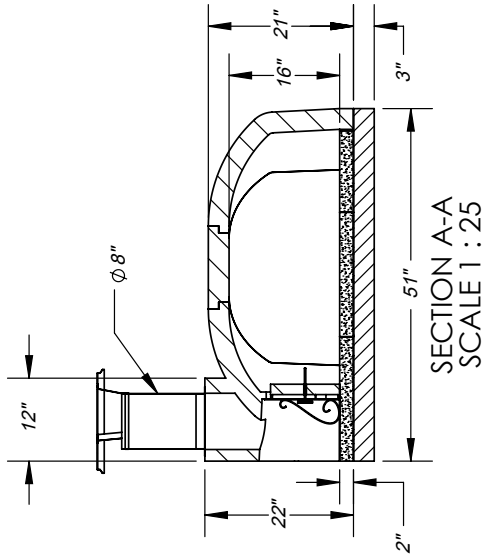
Side Elevation



SECTION A-A
SCALE 1 : 25

Front View

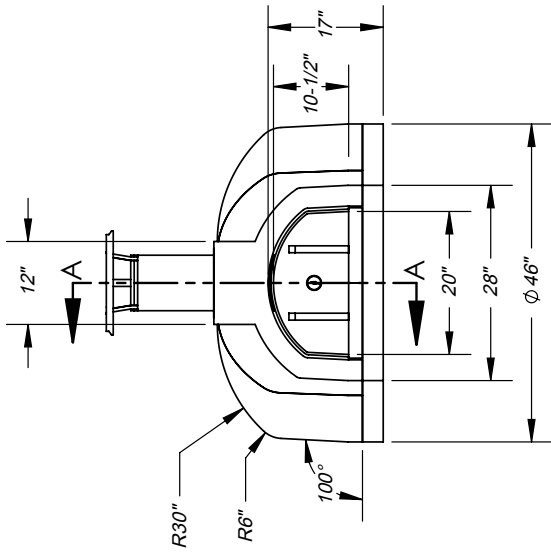

Top View

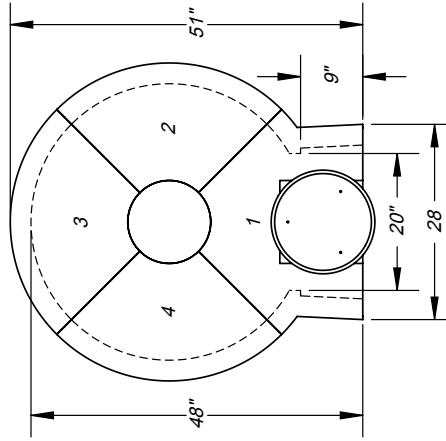

Premio2G 100W Pizza Oven Kit includes:

- Commercial grade refractory oven dome with integral vent
- 3" ceramic fiber insulation board
- 4" ceramic fiber insulation blanket (multiple 1" thick blankets)
- NSF-4 rated fireclay cooking surface
- High temp refractory mortar to seal dome joints
- Single wall stove pipe, anchor plate, 24" pipe and cap
- Double wall insulated steel door
- Door thermometer

Sold separately:

- UL certified spark arrester
- Decorative brick arch
- Double wall insulated steel door to retain heat longer
- Cucina stand with steel frame and hardie-backer board pre-cut
- Stove pipe extension
- Upgrade to double wall chimney for indoor installations / covered patios
- Pizza Oven Tools, infrared thermometer, gloves and other items

To be provided by customer / contractor:

- Concrete support pad with rebar (or equivalent structure)
- Concrete masonry stand (CMU) or equivalent non-combustible structure
- Decorative facade materials (stucco, brick, tile, steel, etc.)

Certifications:

Tested and compliant with:
 UL737, UL2162, NSF-4, CAN/CGA-1.8 Dual, ANSI-Z83.11 Dual, ANSI-Z21.58-CSA 1.6-2007
 For more information about our certifications, click here: www.fornobravo.com/ul-certified

WARNING:

READ ALL INSTRUCTIONS IN INSTALLATION MANUAL BEFORE INSTALLING AND USING APPLIANCE. FAILURE TO FOLLOW INSTRUCTIONS MAY RESULT IN PROPERTY DAMAGE, BODILY INJURY OR EVEN DEATH
 Installation manual can be found by clicking on this link: www.fornobravo.com/PDF/residential_install.pdf

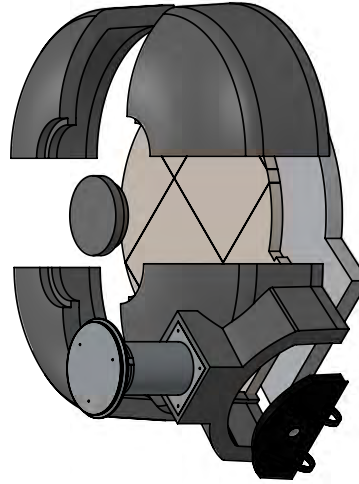

Made in the U.S.A. Residential Wood Fired Pizza Oven

FORNO BRAVO®
 THE WORLD'S FINEST PIZZA OVENS



Premio2G 100W
 Wood Fired Pizza Oven
 Architect Drawings

Revision 6/22/2016 Sheet: 5 of 6

ISO View

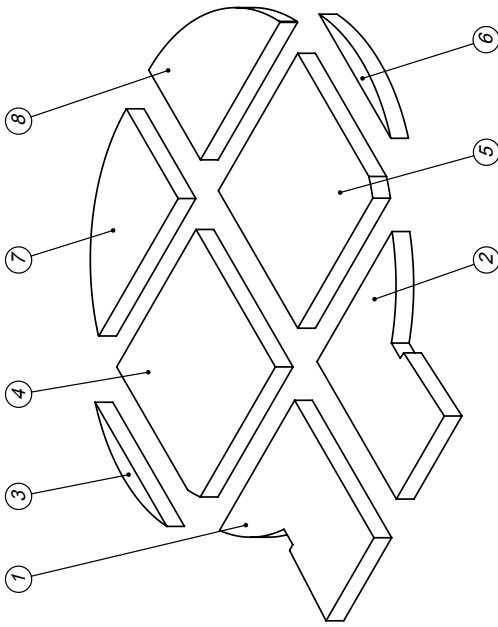

When ordering replacement tiles, reference tile number, pizza oven model and date of purchase.

Top View

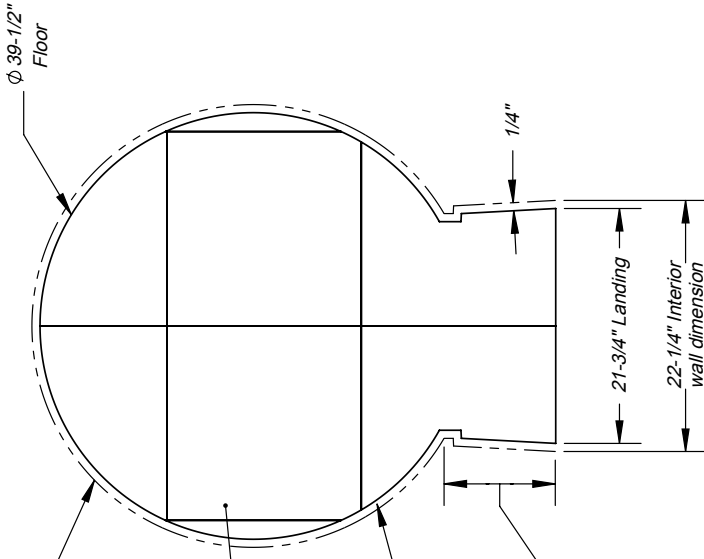

Ø 40" Interior dome dimension

Pizza oven floor designed to allow approximately 1/2" gap between cooking surface and interior dome for thermal expansion and contraction during operation.

Do not fill inside wall with mortar or similar bonding agent. If preferred the space can be filled with sand.

Gaps between the wall and front landing can be filled with mortar or equivalent bonding agent.

Side Elevation

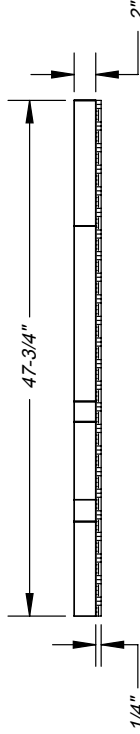

1/4" mortar, sairset, or #60 mesh sand to level pizza oven floor.

Specifications:

Pizza oven floor is NSF-4 rated with 2" thick surface.

Use 1/4" mortar, sairset, or #60 mesh sand to level the pizza oven floor.

No more than 3/8" filler around landing or door may not fit.

WARNING:
READ ALL INSTRUCTIONS IN INSTALLATION MANUAL BEFORE INSTALLING AND USING APPLIANCE. FAILURE TO FOLLOW INSTRUCTIONS MAY RESULT IN PROPERTY DAMAGE, BODILY INJURY OR EVEN DEATH.

Made in the U.S.A.

Residential Wood Fired Pizza Oven



Premio2G 100W

Pizza Oven Floor Tile Layout
 Architect Drawings

Revision 6/22/2016 Sheet: 6 of 6



For more information: www.fornobravo.com
 Installation guide: www.fornobravo.com/PDF/residential_install.pdf

Front View

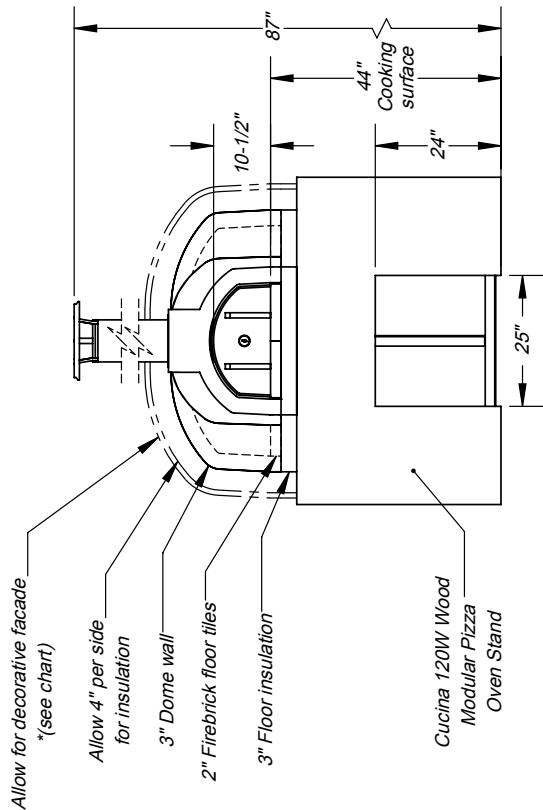

Side Elevation

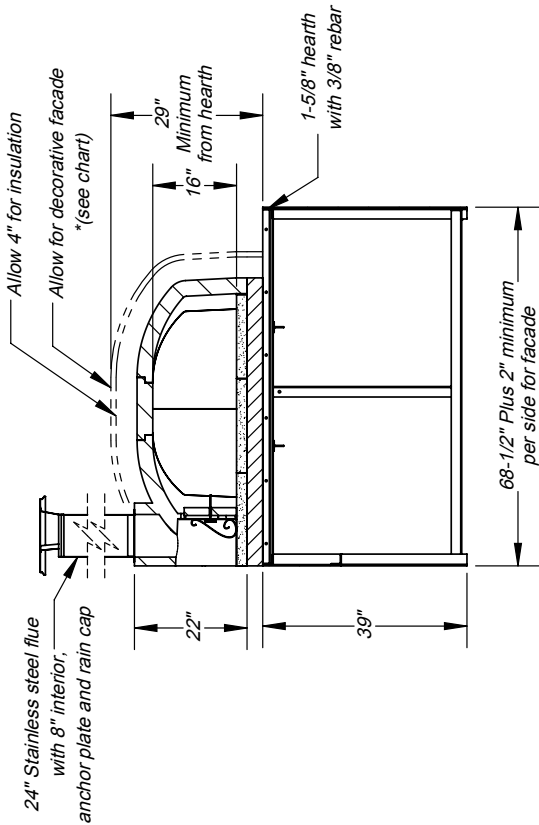

Top View

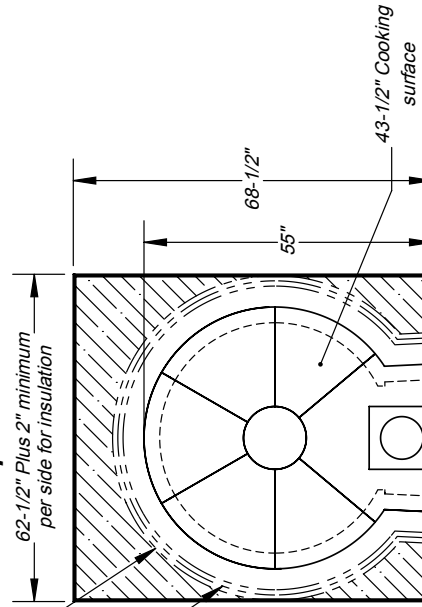

Shown with Forno Bravo Cucina 120W oven stand with non-combustible hearth *(Stand sold separately)

Clearance to combustibles:

- 1" clearance all the way around side walls;
- 14" above completed dome assembly;
- 30" Side clearance from door opening;
- 36" from front of oven landing to combustibles;
- Non-combustible hearth.

Specifications:

- Wood fuel;
- 24" Stainless steel flue with 8" interior, rain cap and anchor plate comes standard.
- Crate ships 66"W x 72"D x 49"H;
- Oven and stand weight: 2405 lbs..

WARNING:
READ ALL INSTRUCTIONS IN INSTALLATION MANUAL BEFORE INSTALLING AND USING APPLIANCE. FAILURE TO FOLLOW INSTRUCTIONS MAY RESULT IN PROPERTY DAMAGE, BODILY INJURY OR EVEN DEATH.

Made in the U.S.A.

FORNO BRAVO®
 Residential Wood Fired Pizza Oven

Premio2G 110W

Wood Fired Pizza Oven w/ Stand

Architect Drawings SKU: FP2G110-SS-W

Revision 6/22/2016 Sheet: 1 of 6

Decorative Facade Allowances	Depth	Width
Brick Arch	Usually 5"	N/A
Brick Lancing	Usually 8"	Preference
Stucco	Approx 1"	N/A
Tile	Approx 1"	Approx 2"
Stone/Brick Veneer	Approx 1"	N/A
Brick or Masonary non veneer	Check Material Spec	N/A
UL737, UL2162, NSF-4, CAN/CGA-1.8 Dual, ANSI-Z83.11 Dual, ANSI-Z21.58, CSA 1.6-2007 Listed For more information: www.fornobravo.com		



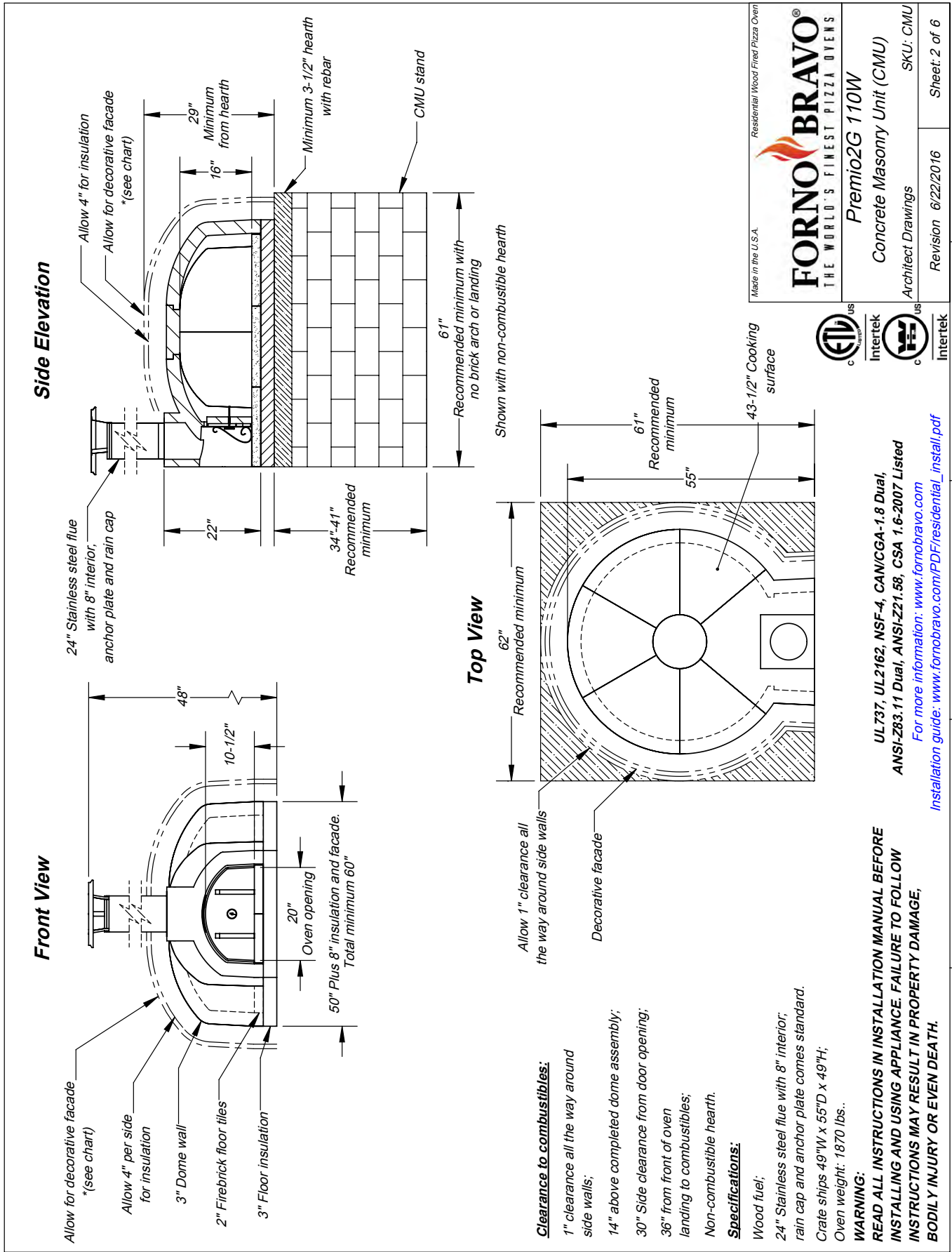

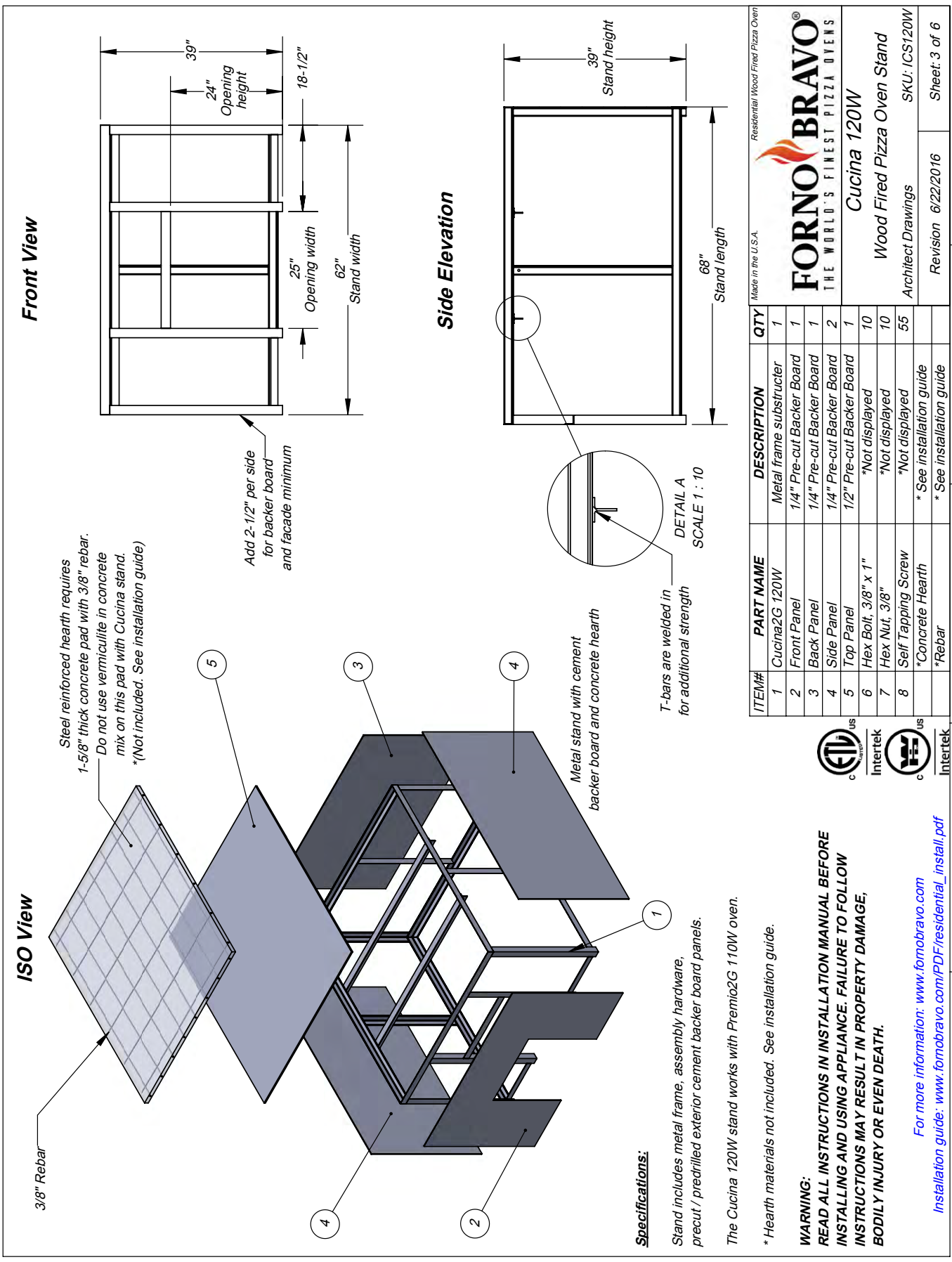

 FORNO BRAVO® THE WORLD'S FINEST PIZZA OVENS Residential Wood Fired Pizza Oven	
Cucina 120W Wood Fired Pizza Oven Stand Architect Drawings SKU: ICS120W	
Revision 6/22/2016 Sheet: 3 of 6	

ITEM#	PART NAME	DESCRIPTION	QTY
1	Cucina2G 120W	Metal frame substructure	1
2	Front Panel	1/4" Pre-cut Backer Board	1
3	Back Panel	1/4" Pre-cut Backer Board	1
4	Side Panel	1/4" Pre-cut Backer Board	2
5	Top Panel	1/2" Pre-cut Backer Board	1
6	Hex Bolt, 3/8" x 1"	*Not displayed	10
7	Hex Nut, 3/8"	*Not displayed	10
8	Self Tapping Screw	*Not displayed	55
		*Concrete Hearth	* See installation guide
		*Rebar	* See installation guide

Specifications:
 Stand includes metal frame, assembly hardware, pre-cut / predrilled exterior cement backer board panels.
 The Cucina 120W stand works with Premio2G 110W oven.
 * Hearth materials not included. See installation guide.
WARNING:
READ ALL INSTRUCTIONS IN INSTALLATION MANUAL BEFORE INSTALLING AND USING APPLIANCE. FAILURE TO FOLLOW INSTRUCTIONS MAY RESULT IN PROPERTY DAMAGE, BODILY INJURY OR EVEN DEATH.
 For more information: www.fornobravo.com
 Installation guide: www.fornobravo.com/PDF/residential_install.pdf

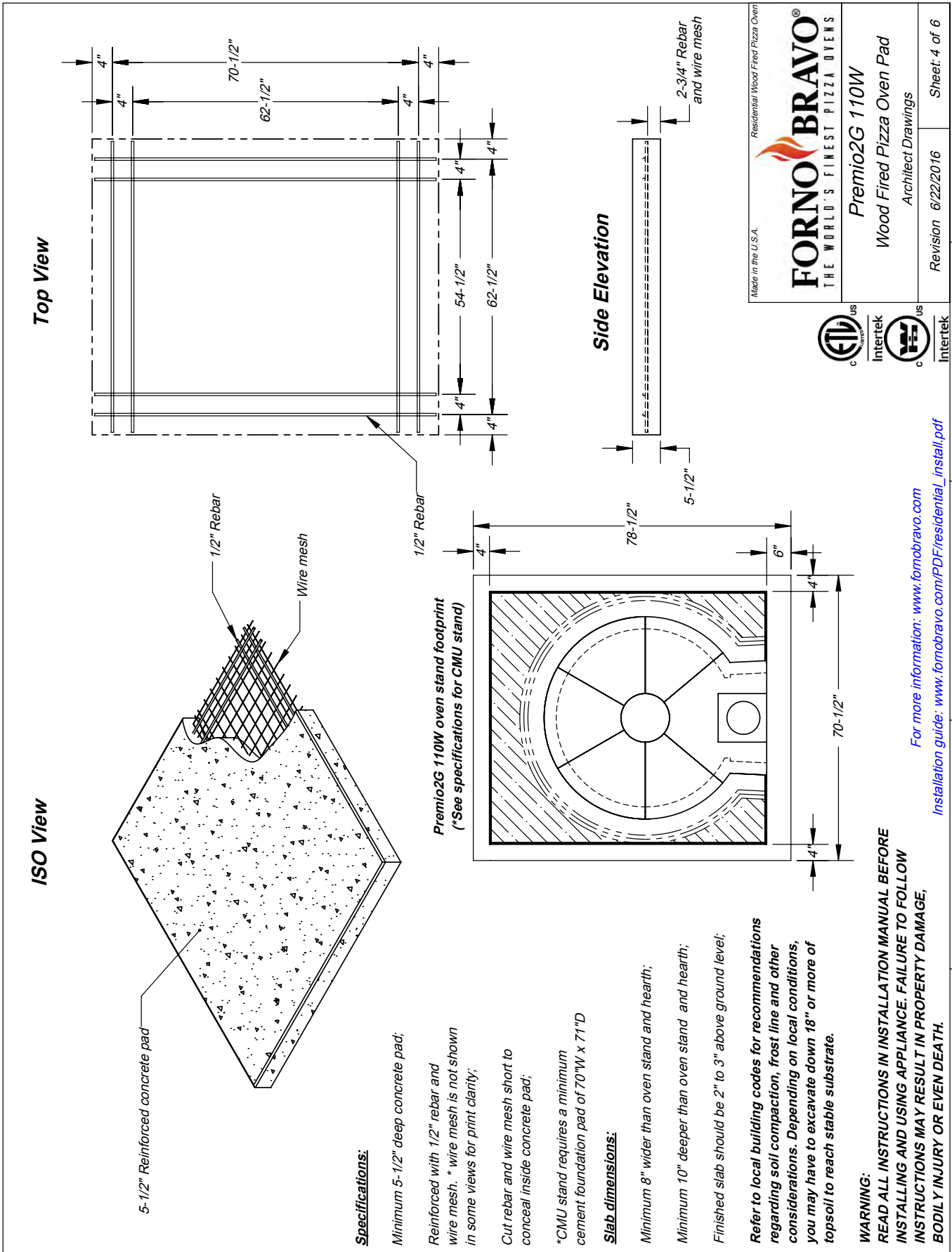

Side Elevation

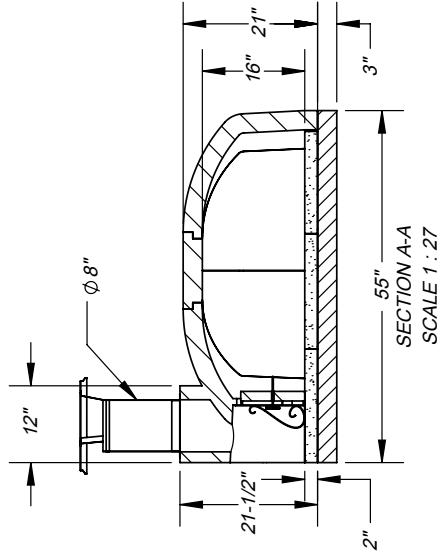

Front View

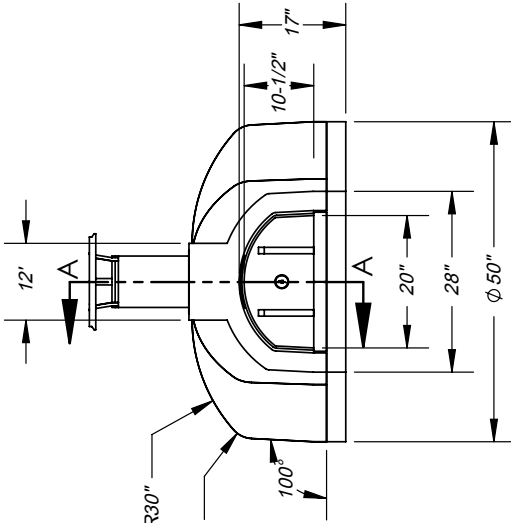

Premio2G 110W Pizza Oven Kit includes:

- Commercial grade refractory oven dome with integral vent
- 3" ceramic fiber insulation board
- 4" ceramic fiber insulation blanket (multiple 1" thick blankets)
- NSF-4 rated fireclay cooking surface
- High temp refractory mortar to seal dome joints
- Single wall stove pipe, anchor plate, 24" pipe and cap
- Double wall insulated steel door
- Door thermometer

Sold separately:

- UL certified spark arrester
- Decorative brick arch
- Double wall insulated steel door to retain heat longer
- Cucina stand with steel frame and handle-backer board pre-cut
- Stove pipe extension
- Upgrade to double wall chimney for indoor installations / covered patios
- Pizza Oven Tools, infrared thermometer, gloves and other items

To be provided by customer / contractor:

- Concrete support pad with rebar (or equivalent structure)
- Concrete masonry stand (CMU) or equivalent non-combustible structure
- Decorative facade materials (stucco, brick, tile, steel, etc.)

Certifications:

Tested and compliant with:
 UL737, UL2162, NSF-4, CAN/CGA-1.8 Dual, ANSI-Z83.11 Dual, ANSI-Z21.58-CSA 1.6-2007
 For more information about our certifications, click here: www.fornobravo.com/ul-certified

WARNING:

READ ALL INSTRUCTIONS IN INSTALLATION MANUAL BEFORE INSTALLING AND USING APPLIANCE. FAILURE TO FOLLOW INSTRUCTIONS MAY RESULT IN PROPERTY DAMAGE, BODILY INJURY OR EVEN DEATH
 Installation manual can be found by clicking on this link: www.fornobravo.com/PDF/residential_install.pdf

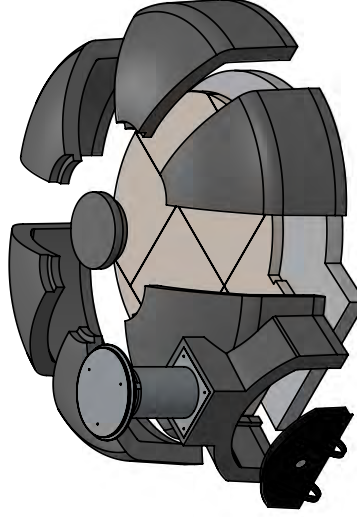

Top View

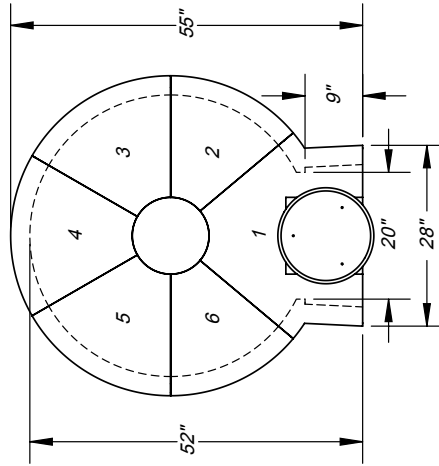

Made in the U.S.A. Residential Wood Fired Pizza Oven

FORNO BRAVO®
 THE WORLD'S FINEST PIZZA OVENS

Premio2G 110W
 Wood Fired Pizza Oven
 Architect Drawings

Revision 6/22/2016 Sheet: 5 of 6



ISO View

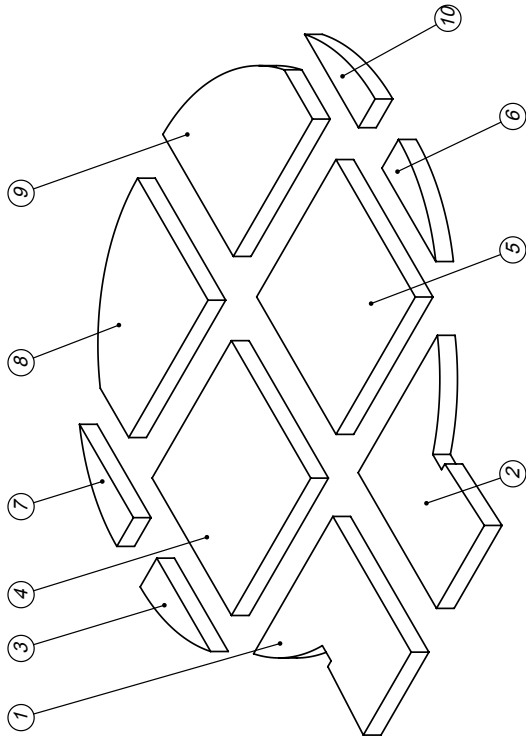

When ordering replacement tiles, reference tile number, pizza oven model and date of purchase.

Top View

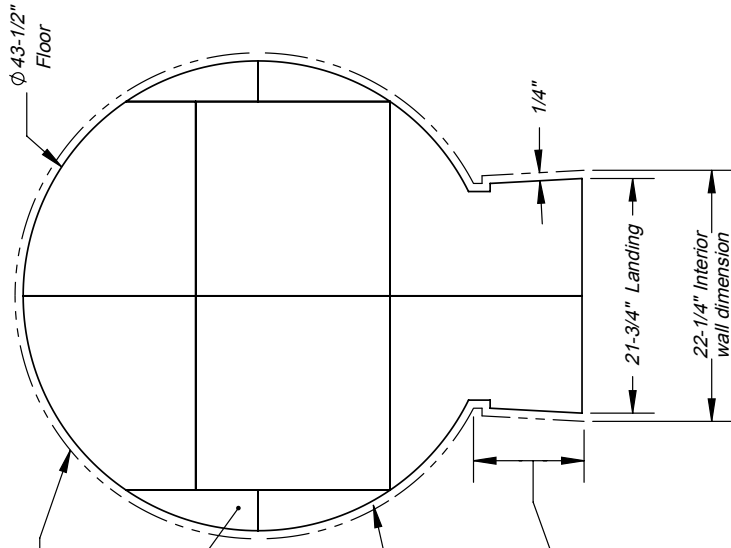

Pizza oven floor designed to allow approximately 1/2" gap between cooking surface and interior dome for thermal expansion and contraction during operation.

Do not fill inside wall with mortar or similar bonding agent. If preferred the space can be filled with sand.

Gaps between the wall and front landing can be filled with mortar or equivalent bonding agent.

Side Elevation

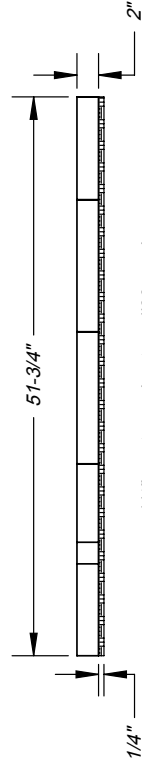

1/4" mortar, sairsset, or #60 mesh sand to level pizza oven floor.

Specifications:

Pizza oven floor is NSF-4 rated with 2" thick surface.

Use 1/4" mortar, sairsset or #60 mesh sand to level the floor.

No more than 3/8" filler around landing or door may not fit.

WARNING:
READ ALL INSTRUCTIONS IN INSTALLATION MANUAL BEFORE INSTALLING AND USING APPLIANCE. FAILURE TO FOLLOW INSTRUCTIONS MAY RESULT IN PROPERTY DAMAGE, BODILY INJURY OR EVEN DEATH.

Made in the U.S.A. Commercial Wood Fired Pizza Oven



Premio2G 110W

Pizza Oven Floor Tile Layout
Architect Drawings

Revision 6/22/2016 Sheet: 6 of 6



For more information: www.fornobravo.com
Installation guide: www.fornobravo.com/PDF/residential_install.pdf

Front View

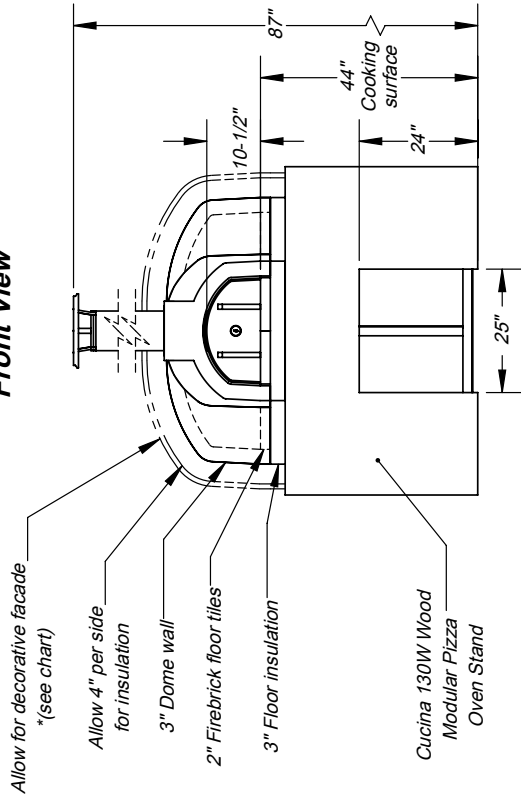

Side Elevation

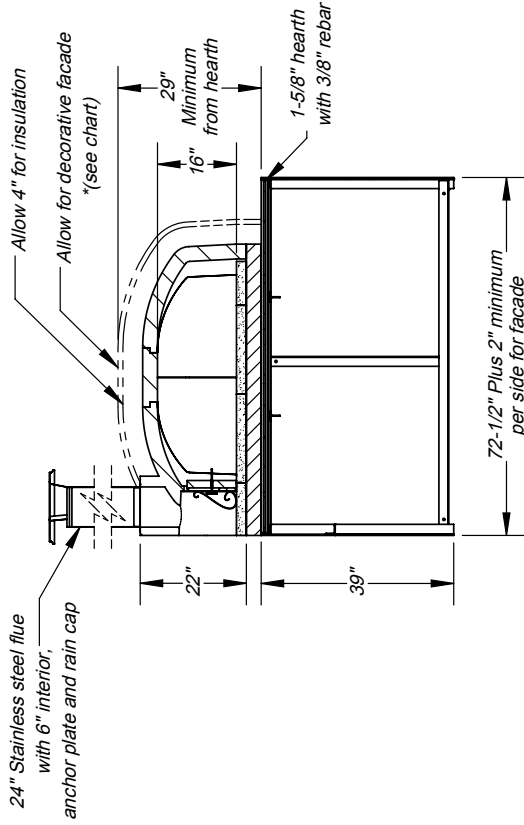

Top View

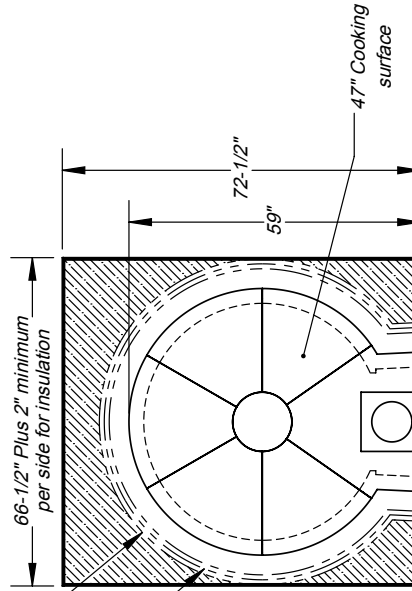

Shown with Forno Bravo Cucina 130W oven stand with non-combustible hearth *(Stand sold separately)

Clearance to combustibles:

- 1" clearance all the way around side walls;
- 14" above completed dome assembly;
- 30" Side clearance from door opening;
- 36" from front of oven landing to combustibles;
- Non-combustible hearth.

Specifications:

- Wood fuel;
- 24" Stainless steel flue with 8" interior; rain cap and anchor plate comes standard.
- Crate ships 70"W x 76"D x 49"H;
- Oven and stand weight: 2538 lbs..

WARNING:

READ ALL INSTRUCTIONS IN INSTALLATION MANUAL BEFORE INSTALLING AND USING APPLIANCE. FAILURE TO FOLLOW INSTRUCTIONS MAY RESULT IN PROPERTY DAMAGE, BODILY INJURY OR EVEN DEATH.

Made in the U.S.A.		Residential Wood Fired Pizza Oven	
		Decorative Facade Allowances	Width
		Brick Arch	N/A
		Brick Landing	Preference
		Stucco	N/A
		Tile	Approx 2"
		Stone/Brick Veneer	Approx 1"
		Brick or Masonry non veneer	Check Material Spec
		UL737, UL2162, NSF-4, CAN/CGA-1.8 Dual, ANSI-Z83.11 Dual, ANSI-Z21.58, CSA 1.6-2007 Listed For more information: www.fornobravo.com Installation guide: www.fornobravo.com/PDF/residential_install.pdf	N/A
Architect Drawings		SKU: FP2G120-SS-W	
Revision 6/22/2016		Sheet: 1 of 6	

Front View

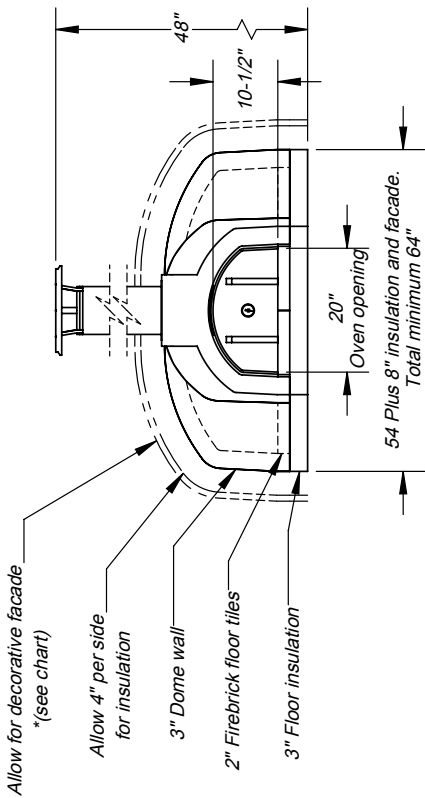

Side Elevation

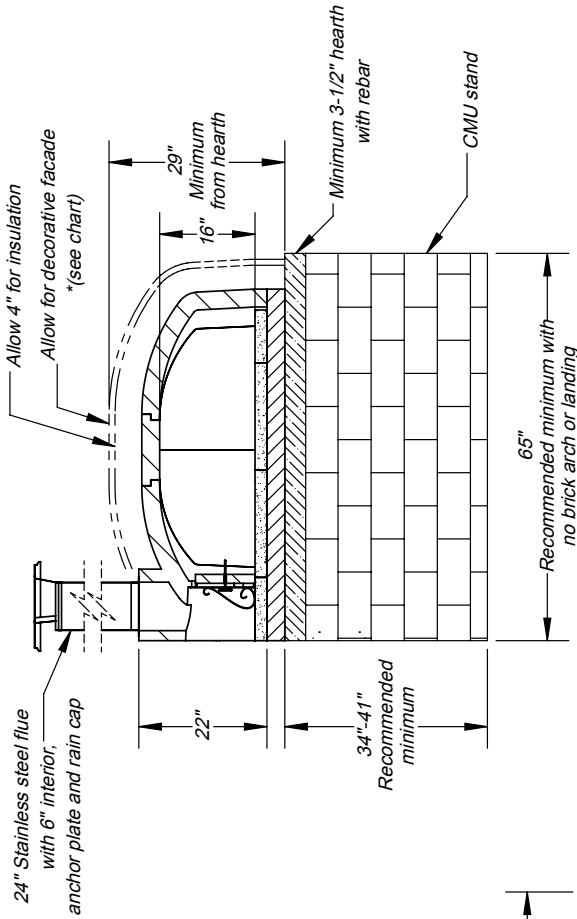

Top View

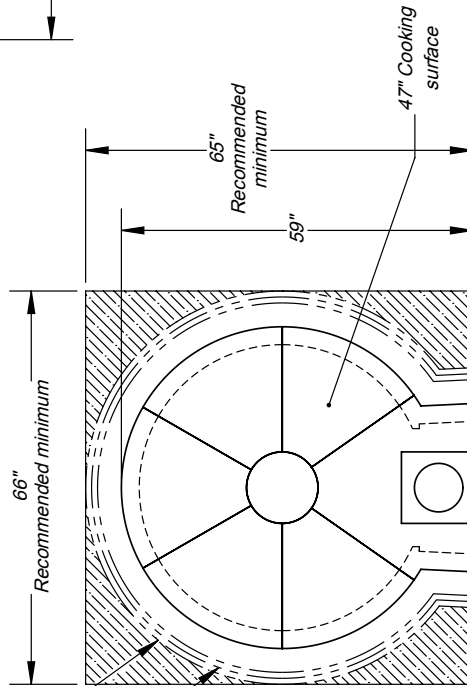

Allow 1" clearance all the way around side walls

Decorative facade

Clearance to combustibles:

- 1" clearance all the way around side walls;
- 14" above completed dome assembly;
- 30" Side clearance from door opening;
- 36" from front of oven landing to combustibles;
- Non-combustible hearth.

Specifications:

- Wood fuel;
- 24" Stainless steel flue with 8" interior; rain cap and anchor plate comes standard.
- Crate ships 49"W x 58"D x 50"H;
- Oven weight: 2003 lbs..

WARNING:

READ ALL INSTRUCTIONS IN INSTALLATION MANUAL BEFORE INSTALLING AND USING APPLIANCE. FAILURE TO FOLLOW INSTRUCTIONS MAY RESULT IN PROPERTY DAMAGE, BODILY INJURY OR EVEN DEATH.

Made in the U.S.A.

Residential Gas Fired Pizza Oven

Premio2G 120W
Wood Fired Pizza Oven

Architect Drawings SKU: CMU

Revision 6/22/2016 Sheet: 2 of 6

Decorative Facade Allowances	Depth	Width
Brick Arch	Usually 5"	N/A
Brick Lancing	Usually 8"	Preference
Stucco	Approx 1"	N/A
Tile	Approx 1"	Approx 2"
Stone/Brick Veneer	Approx 1"	N/A
Brick or Masonary non veneer	Check Material Spec	N/A
UL737, UL2162, NSF-4, CAN/CGA-1.8 Dual, ANSI-Z83.11 Dual, ANSI-Z21.58, CSA 1.6-2007 Listed For more information: www.fornobravo.com		



ISO View

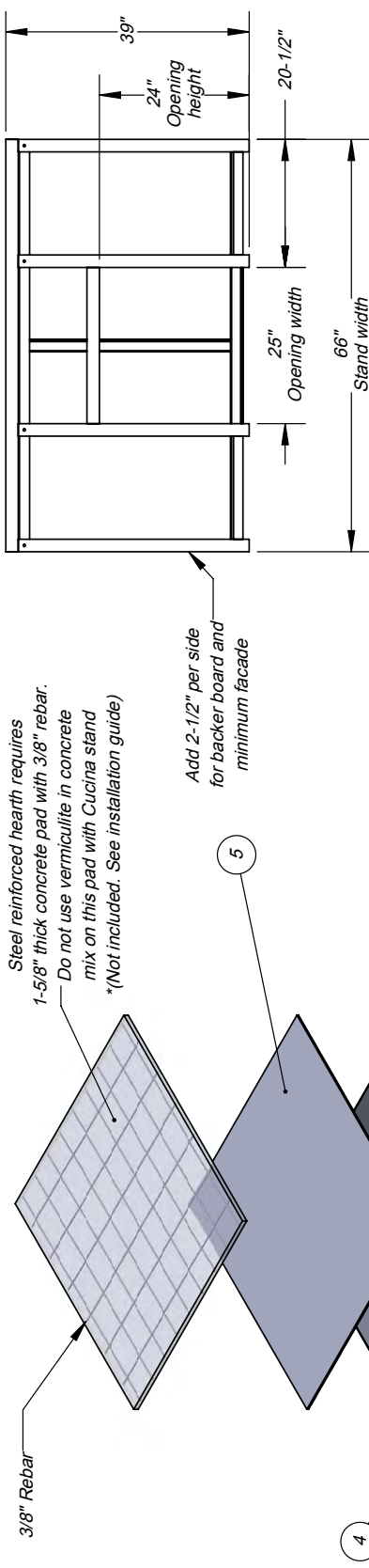

Steel reinforced hearth requires 1-5/8" thick concrete pad with 3/8" rebar. Do not use vermiculite in concrete mix on this pad with Cucina stand *(Not included. See installation guide)

Add 2-1/2" per side for backer board and minimum facade

Opening designed for wood storage below hearth

Specifications:
Stand includes metal frame, assembly hardware, pre-cut / prefrilled exterior cement backer board panels.

The Cucina 130W stand works with Premio2G 120W oven.

* Hearth materials not included. See installation guide.

WARNING:
READ ALL INSTRUCTIONS IN INSTALLATION MANUAL BEFORE INSTALLING AND USING APPLIANCE. FAILURE TO FOLLOW INSTRUCTIONS MAY RESULT IN PROPERTY DAMAGE, BODILY INJURY OR EVEN DEATH.

For more information: www.fornobravo.com
Installation guide: www.fornobravo.com/PDF/residential_install.pdf

Front View

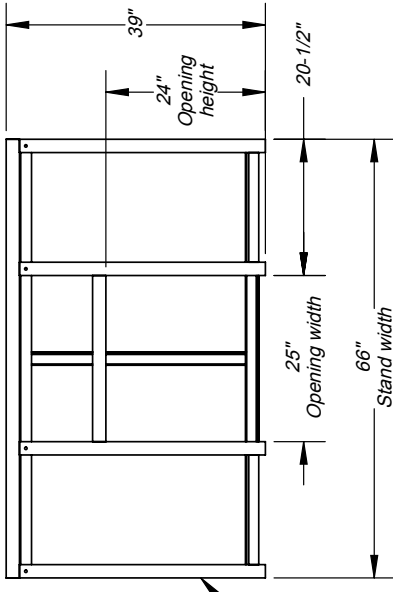

Side Elevation

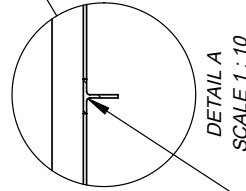
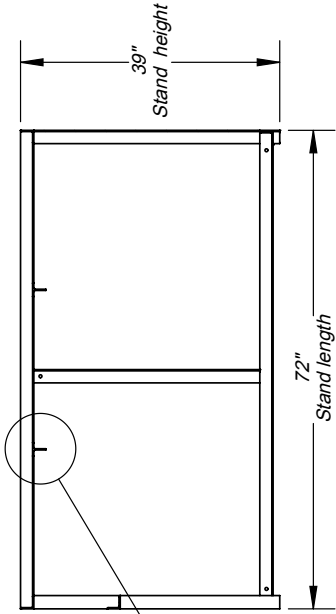

ITEM#	PART NAME	DESCRIPTION	QTY
1	Cucina2G 130W	Metal frame substructure	1
2	Front Panel	1/4" Pre-cut Backer Board	1
3	Back Panel	1/4" Pre-cut Backer Board	1
4	Side Panel	1/4" Pre-cut Backer Board	2
5	Top Panel	1/2" Pre-cut Backer Board	1
6	Control Box Mount	Secures burner control unit	1
7	Hex Bolt, 3/8" x 1"	*Not displayed	10
8	Hex Nut, 3/8"	*Not displayed	10
9	Self Tapping Screw	*Not displayed	55
	*Concrete Hearth	* See installation guide	
	*Rebar	* See installation guide	



Made in the U.S.A.

FORNO BRAVO®
THE WORLD'S FINEST PIZZA OVENS

Cucina 130W

Wood Fired Pizza Oven Stand

Architect Drawings SKU: ICS130W

Revision 6/22/2016 Sheet: 3 of 6

Front View

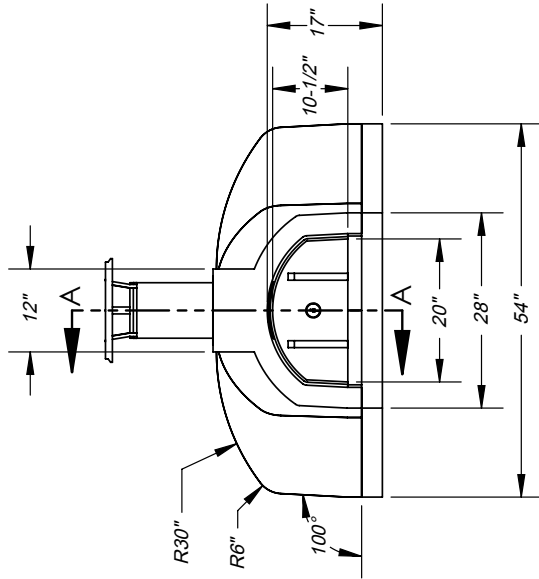

Premio2G 120W Pizza Oven Kit includes:

- Commercial grade refractory oven dome with integral vent
- 3" ceramic fiber insulation board
- 4" ceramic fiber insulation blanket (multiple 1" thick blankets)
- NSF-4 rated fireclay cooking surface
- High temp refractory mortar to seal dome joints
- Single wall stove pipe, anchor plate, 24" pipe and cap
- Double wall insulated steel door
- Door thermometer

Sold separately:

- UL certified spark arrester
- Decorative brick arch
- Double wall insulated steel door to retain heat longer
- Cucina stand with steel frame and handle-backer board pre-cut
- Stove pipe extension
- Upgrade to double wall chimney for indoor installations / covered patios
- Pizza Oven Tools, infrared thermometer, gloves and other items

To be provided by customer / contractor:

- Concrete support pad with rebar (or equivalent structure)
- Concrete masonry stand (CMU) or equivalent non-combustible structure
- Decorative facade materials (stucco, brick, tile, steel, etc.)

Certifications:

Tested and compliant with:
UL737, UL2162, NSF-4, CAN/CGA-1.8 Dual, ANSI-Z83.11 Dual, ANSI-Z83.11 Dual, ANSI-Z221.58-CSA 1.6-2007
For more information about our certifications, click here: www.fornobravo.com/ul-certified

WARNING:

READ ALL INSTRUCTIONS IN INSTALLATION MANUAL BEFORE INSTALLING AND USING APPLIANCE. FAILURE TO FOLLOW INSTRUCTIONS MAY RESULT IN PROPERTY DAMAGE, BODILY INJURY OR EVEN DEATH
Installation manual can be found by clicking on this link: www.fornobravo.com/PDF/residential_install.pdf

5

4

3

2

1

Side Elevation

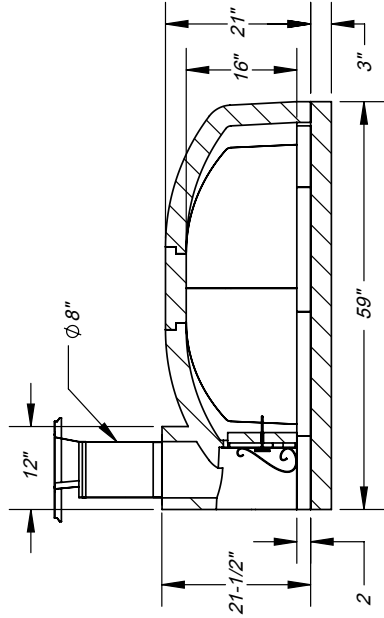

**SECTION A-A
SCALE 1 : 25**

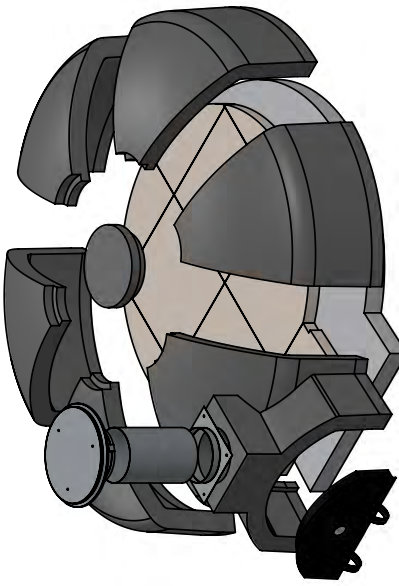

Top View

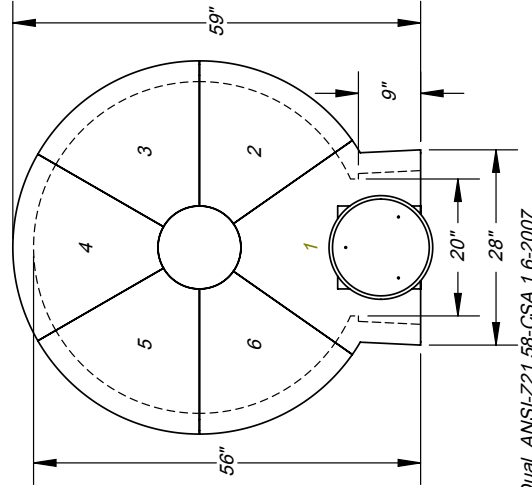

Made in the U.S.A. Residential Wood Fired Pizza Oven

FORNO BRAVO®
THE WORLD'S FINEST PIZZA OVENS



Intertek



Intertek

Premio2G 120W

Wood Fired Pizza Oven
Architect Drawings

Revision 6/22/2016 Sheet: 5 of 6

ISO View

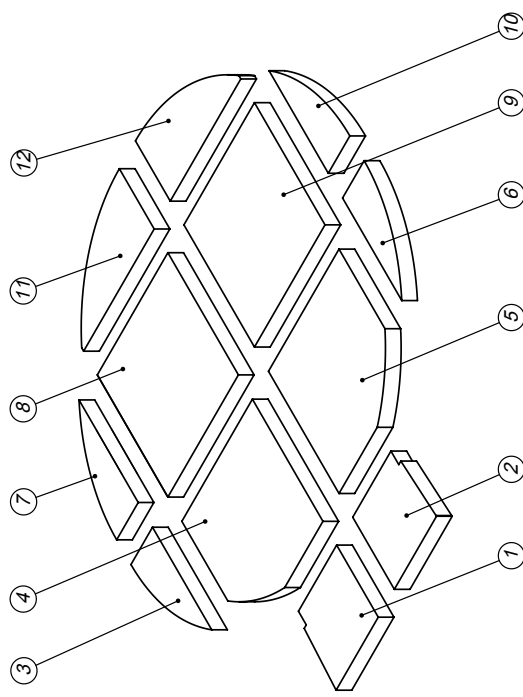

When ordering replacement tiles, reference tile number, pizza oven model and purchase date.

Top View

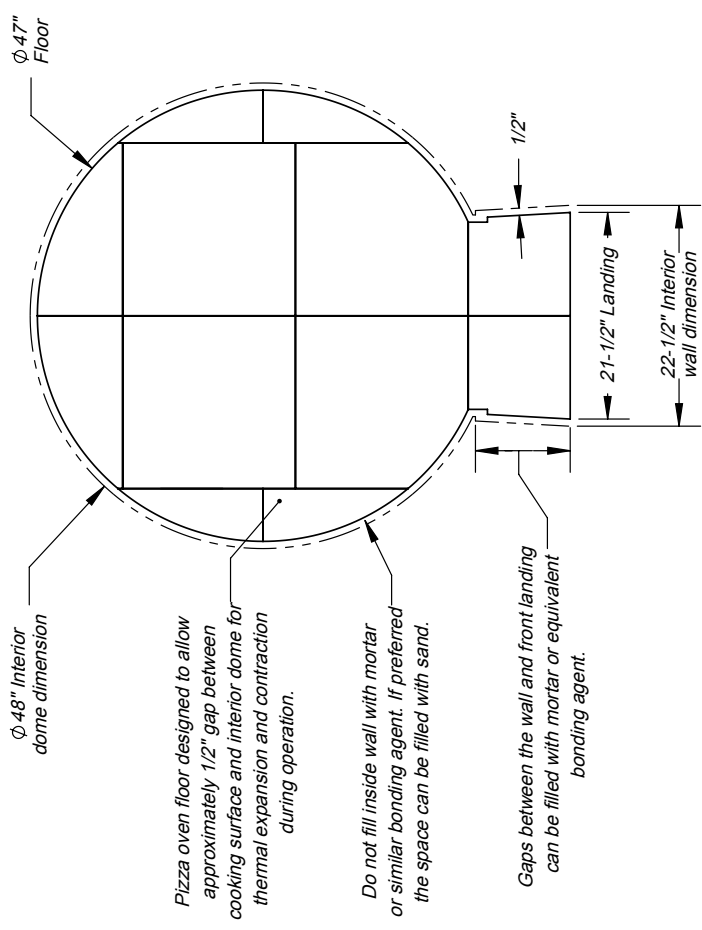

Pizza oven floor designed to allow approximately 1/2" gap between cooking surface and interior dome for thermal expansion and contraction during operation.

Do not fill inside wall with mortar or similar bonding agent. If preferred the space can be filled with sand.

Gaps between the wall and front landing can be filled with mortar or equivalent bonding agent.

Side Elevation

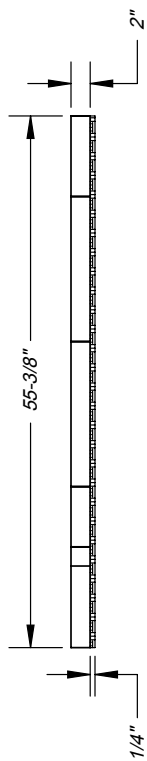

1/4" mortar, sairset, or #60 mesh sand to level pizza oven floor.

Specifications:

Pizza oven floor is NSF-4 rated with 2" thick surface.

Use 1/4" mortar, sairset, or #60 mesh sand to level the pizza oven floor.

No more than 3/8" filler around landing or door may not fit.

WARNING:
READ ALL INSTRUCTIONS IN INSTALLATION MANUAL BEFORE INSTALLING AND USING APPLIANCE. FAILURE TO FOLLOW INSTRUCTIONS MAY RESULT IN PROPERTY DAMAGE, BODILY INJURY OR EVEN DEATH.

ETL Intertek
UL Intertek

www.fornobravo.com
www.fornobravo.com/PDF/residential_install.pdf

FORNO BRAVO
 THE WORLD'S FINEST PIZZA OVENS
 Residential Wood Fired Pizza Oven
Premio2G 120W
 Pizza Oven Floor Tile Layout
 Architect Drawings
 Revision 6/22/2016 Sheet: 6 of 6

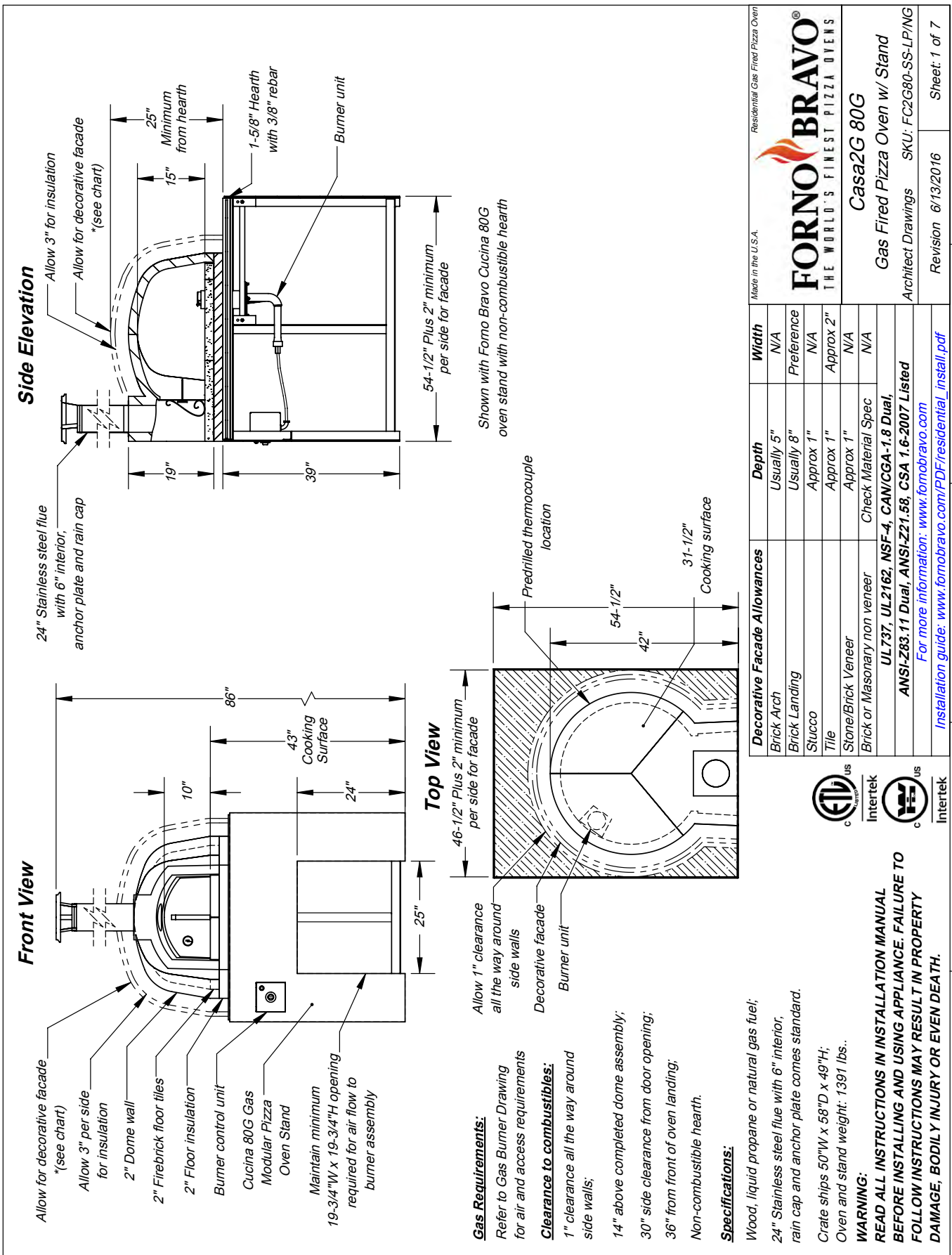

Front View

Side Elevation

Top View

Gas Requirements:

Refer to Gas Burner Drawing for air and access requirements

Clearance to combustibles:

- 1" clearance all the way around side walls;
- 14" above completed dome assembly;
- 30" side clearance from door opening;
- 36" from front of oven landing;
- Non-combustible hearth.

Specifications:

- Wood, liquid propane or natural gas fuel;
- 24" Stainless steel flue with 6" interior, rain cap and anchor plate comes standard.
- Crate ships 50"W x 58"D x 49"H;
- Oven and stand weight: 1391 lbs..

WARNING:

READ ALL INSTRUCTIONS IN INSTALLATION MANUAL BEFORE INSTALLING AND USING APPLIANCE. FAILURE TO FOLLOW INSTRUCTIONS MAY RESULT IN PROPERTY DAMAGE, BODILY INJURY OR EVEN DEATH.

Shown with Forno Bravo Cucina 80G oven stand with non-combustible hearth

Made in the U.S.A.		Residential Gas Fired Pizza Oven	
FORNO BRAVO® THE WORLD'S FINEST PIZZA OVENS			
Casa2G 80G			
Gas Fired Pizza Oven w/ Stand		Architect Drawings SKU: FC2G80-SS-LP/NG	
Revision 6/13/2016		Sheet: 1 of 7	
Decorative Facade Allowances	Depth	Width	
Brick Arch	Usually 5"	N/A	
Brick Landing	Usually 8"	Preference	
Stucco	Approx 1"	N/A	
Tile	Approx 1"	Approx 2"	
Stone/Brick Veneer	Approx 1"	N/A	
Brick or Masonry non veneer	Check Material Spec	N/A	
UL737, UL2162, NSF-4, CAN/CGA-1.8 Dual, ANSI-Z83.11 Dual, ANSI-Z21.58, CSA 1.6-2007 Listed			
For more information: www.fornobravo.com			
Installation guide: www.fornobravo.com/PDF/residential_install.pdf			



Detailed view of burner placement

SCALE 1:4

1-1/2" Floor to top of ignitor
 *(Minimum)

3/4" Floor to top of burner housing
 *(Minimum)

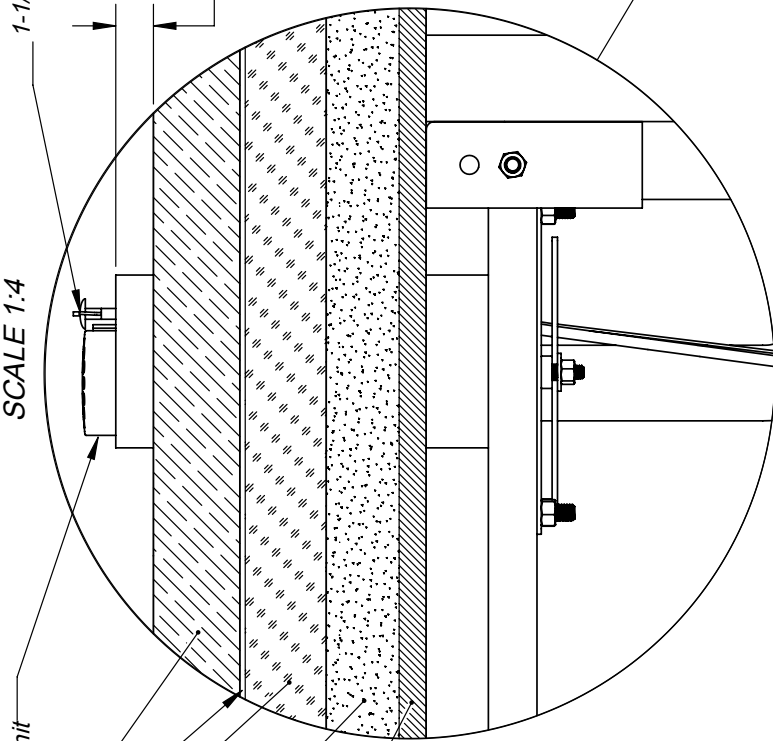

- Drago P1 Plus Burner unit
- 2" Firebrick tiles
- 1/8" - 3/8" Mortar, sisset, or #60 sand used for leveling floor
- 2" Ceramic board floor insulation
- 1-5/8" Concrete hearth with rebar
- 1/2" Backer board

Specifications:

Cucina stand, concrete CMU stand, or equivalent non-combustible structure's front opening requires a minimum of 19-3/4"W x 19-3/4"H for air flow to burner assembly

Gas line should be 1/2" pipe then reduced to 3/8" union

Liquid Propane line pressure 10 to 12 WC

Natural Gas line pressure 5 to 10 WC

Factory settings:

Natural Gas - 2.75 orifice, air shutter at #2 position

Liquid Propane - 2.25 orifice, air shutter at #3 position

WARNING: DO NOT CHANGE FACTORY SETTINGS WITHOUT CONSULTING MANUFACTURER OR CERTIFIED TECHNICIAN.

WARNING: READ ALL INSTRUCTIONS IN INSTALLATION MANUAL BEFORE INSTALLING AND USING APPLIANCE. FAILURE TO FOLLOW INSTRUCTIONS MAY RESULT IN PROPERTY DAMAGE, BODILY INJURY OR EVEN DEATH.

UL approved settings for gas orifices		NG	LP
Input rate w/ 2.5 orifice and air shutter at #2 setting (Btu/hr)		32000	
Input rate w/ 2.7 orifice and air shutter at #2 setting (Btu/hr)		38000	
Input rate w/ 1.75 orifice and air shutter at #3 setting (Btu/hr)			32000
Input rate w/ 2.0 orifice and air shutter at #3 setting (Btu/hr)			43000
Input rate w/ 2.25 orifice and air shutter at #3 setting (Btu/hr)			51000
Input rate w/ 2.5 orifice and air shutter at #4 setting (Btu/hr)			46000

For more information: www.fornobravo.com

Installation guide: www.fornobravo.com/PDF/residential_install.pdf

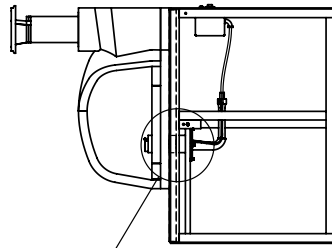

Forno Bravo Casa2G 80G Pizza oven
 and Cucina 80G Modular Pizza Oven Stand

Made in the U.S.A. Residential Gas Fired Pizza Oven



Casa2G 80G	
Gas Burner Detailed View	
Architect Drawings	
Revision 6/13/2016	Sheet: 2 of 7



2

3

4

5

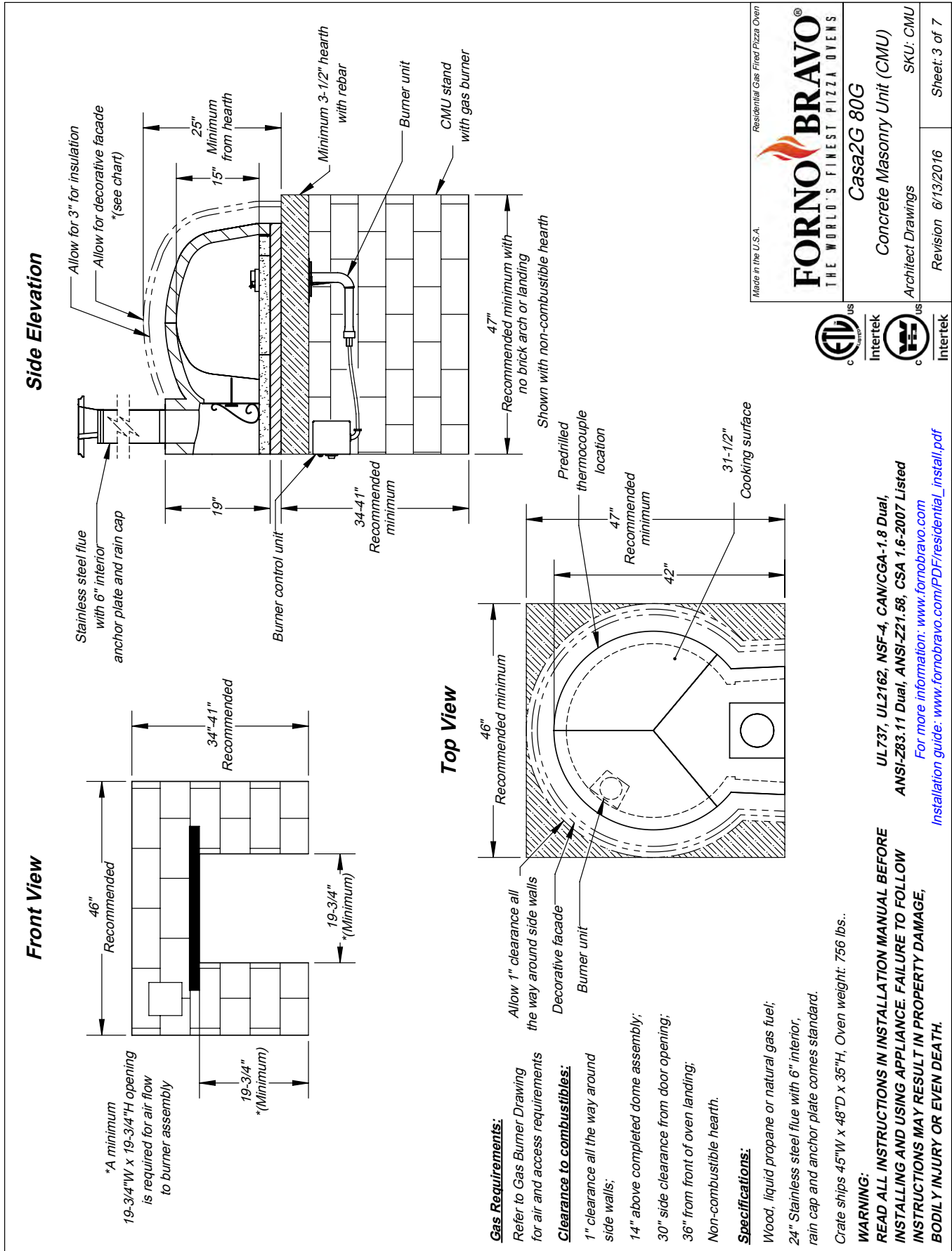

Made in the U.S.A. Residential Gas Fired Pizza Oven

FORNO BRAVO®
 THE WORLD'S FINEST PIZZA OVENS

Casa2G 80G

Concrete Masonry Unit (CMU)

Architect Drawings SKU: CMU

Revision 6/13/2016 Sheet: 3 of 7



1
2
3
4
5

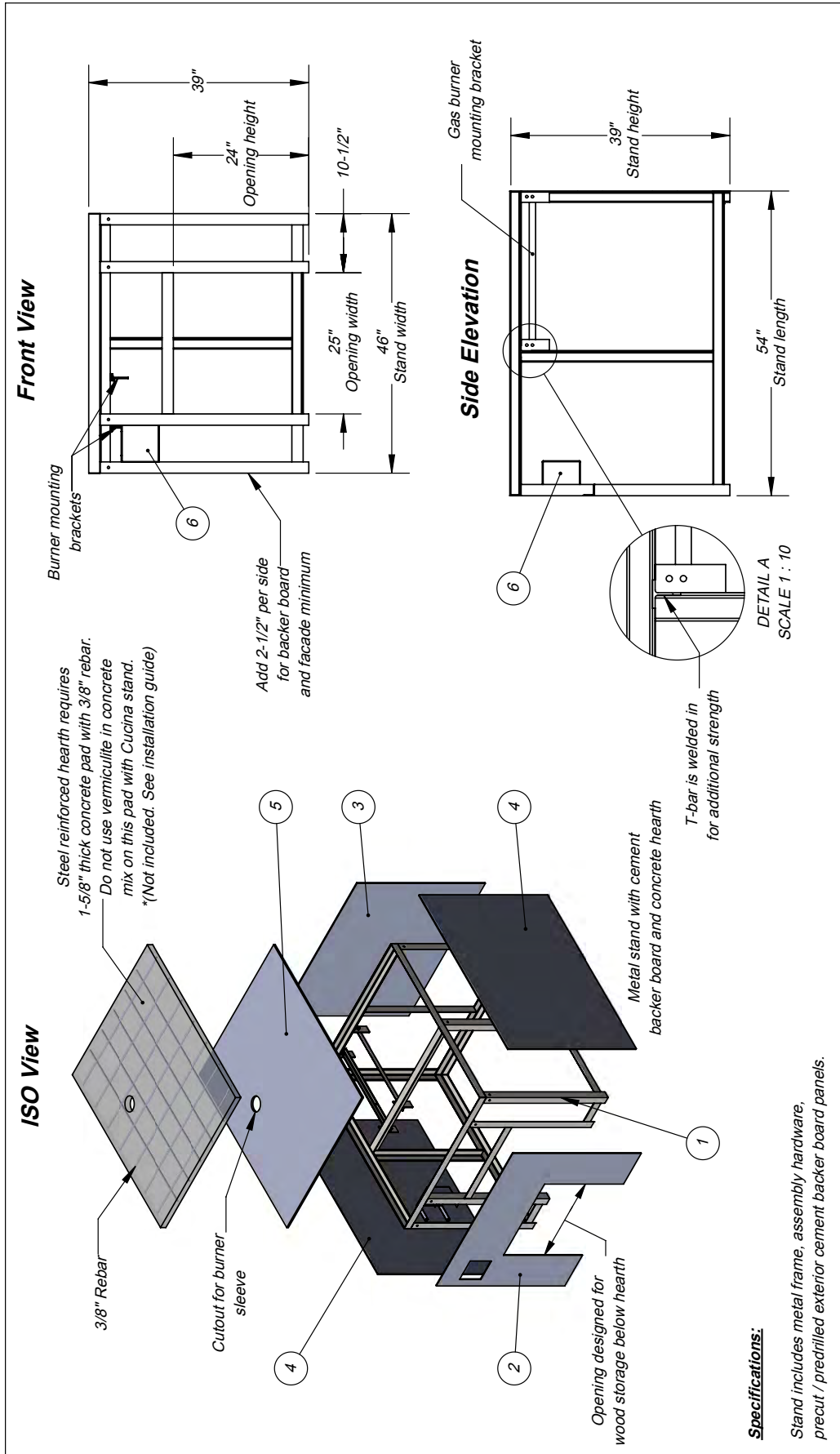

ITEM#	PART NAME	DESCRIPTION	QTY
1	Cucina2G 80G	Metal frame substructure	1
2	Front Panel	1/4" Pre-cut Backer Board	1
3	Back Panel	1/4" Pre-cut Backer Board	1
4	Side Panel	1/4" Pre-cut Backer Board	2
5	Top Panel	1/2" Pre-cut Backer Board	1
6	Control Box Mount	Secures burner control unit	1
7	Hex Bolt, 3/8" x 1"	*Not displayed	10
8	Hex Nut, 3/8"	*Not displayed	10
9	Self Tapping Screw	*Not displayed	55
	*Concrete Hearth	* See installation guide	
	*Rebar	* See installation guide	

Made in the U.S.A.
 Residential Gas Fired Pizza Oven

FORNO BRAVO®
 THE WORLD'S FINEST PIZZA OVENS

Cucina 80G
 Gas Fired Pizza Oven Stand

Architect Drawings
 Revision 6/13/2016
 SKU: ICS80G
 Sheet: 4 of 7

Specifications:
 Stand includes metal frame, assembly hardware, precut / prefilled exterior cement backer board panels.

The Cucina 80G stand works with Casa2G 80G oven.

* Hearth materials not included. See installation guide.

WARNING:
 READ ALL INSTRUCTIONS IN INSTALLATION MANUAL BEFORE INSTALLING AND USING APPLIANCE. FAILURE TO FOLLOW INSTRUCTIONS MAY RESULT IN PROPERTY DAMAGE, BODILY INJURY OR EVEN DEATH.

For more information: www.fornobravo.com
 Installation guide: www.fornobravo.com/PDF/residential_install.pdf



ISO View

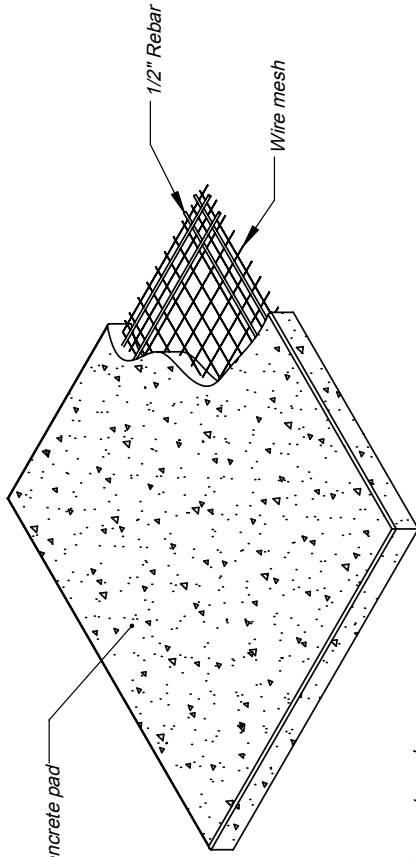

5-1/2" Reinforced concrete pad

1/2" Rebar

Wire mesh

Minimum 5-1/2" deep concrete pad;

Reinforced with 1/2" rebar and wire mesh. * wire mesh is not shown in some views for print clarity;

Cut rebar and wire mesh short to conceal inside concrete pad;

*CMU stand requires a minimum cement foundation pad of 54"W x 57"D

Slab dimensions:

Minimum 8" wider than oven stand and hearth;

Minimum 10" deeper than oven stand and hearth;

Finished slab should be 2" to 3" above ground level;

Refer to local building codes for recommendations regarding soil compaction, frost line and other considerations. Depending on local conditions, you may have to excavate down 18" or more of topsoil to reach stable substrate.

WARNING:
READ ALL INSTRUCTIONS IN INSTALLATION MANUAL BEFORE INSTALLING AND USING APPLIANCE. FAILURE TO FOLLOW INSTRUCTIONS MAY RESULT IN PROPERTY DAMAGE, BODILY INJURY OR EVEN DEATH.

Top View

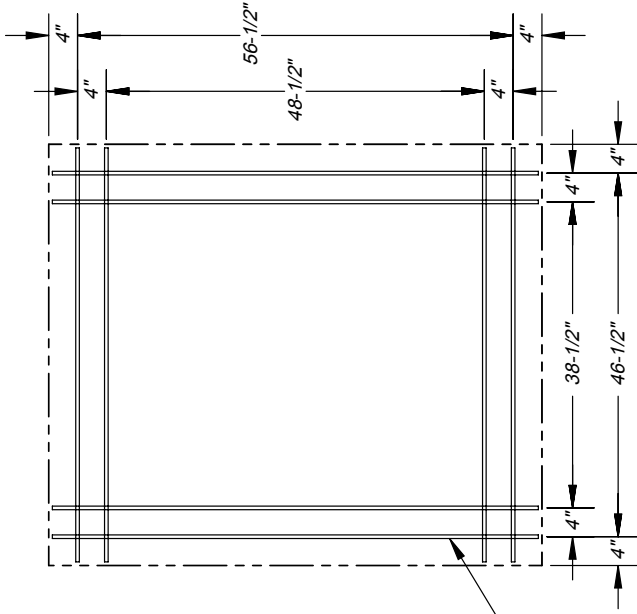

Side Elevation

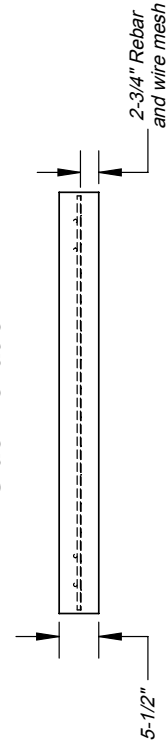

Casa2G 80G oven stand footprint
 (*See specifications for CMU stand)

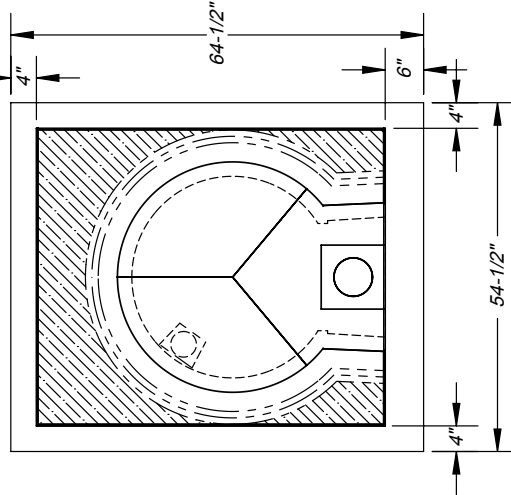

Made in the U.S.A.

FORNO BRAVO®
 THE WORLD'S FINEST PIZZA OVENS

Residential Gas Fired Pizza Oven

Casa2G 80G
 Gas Fired Pizza Oven Pad
 Architect Drawings

Revision 6/13/2016

Sheet 5 of 7



For more information: www.fornobravo.com
 Installation guide: www.fornobravo.com/PDF/residential_install.pdf

Front View

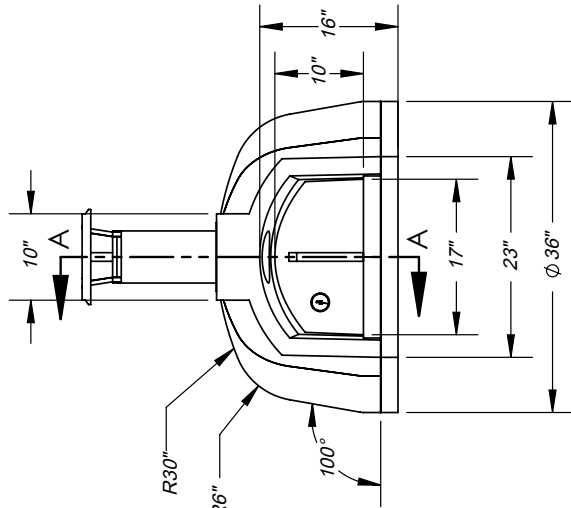

Casa2G 80G Pizza Oven Kit includes:

- Commercial grade refractory oven dome with integral vent
- 2" ceramic fiber insulation board
- 3" ceramic fiber insulation blanket (multiple 1" thick blankets)
- NSF-4 rated fireclay cooking surface
- High temp refractory mortar to seal dome joints
- Single wall stove pipe, anchor plate, 24" pipe and cap
- Single wall steel powder coated door
- Door thermometer

Home Gas Features includes:

- Fuel: Wood, liquid propane or natural gas
- Drago P1 Plus burner assembly (specify, natural gas or liquid propane)
- Burner ignition box with four settings (off, pilot, low and high flame)
- Stainless steel ash guard for burner
- Remote thermometer
- Gas leak detector
- Propane Gas valve regulator. *(Note: Natural gas regulator must be supplied by local certified installer.)

Sold separately:

- UL certified spark arrester
- Decorative brick arch
- Double wall insulated steel door to retain heat longer
- Cucina stand with steel frame and hardie-backer board precut
- Stove pipe extensions
- Upgrade to double wall chimney for indoor installations / covered patios
- Pizza Oven Tools, infrared thermometer, gloves and other items

To be provided by customer / contractor:

- Concrete support pad with rebar (or equivalent structure)
- Concrete masonry stand (CMU) or equivalent non-combustible structure
- Decorative facade materials (stucco, brick, tile, steel, etc.)

Certifications:

Tested and compliant with:
UL737, UL2162, NSF-4, CAN/CGA-1.8 Dual, ANSI-Z83.11 Dual, ANSI-Z21.58, CSA 1.6-2007
For more information about our certifications, click here: www.fornobravo.com/ul-certified

WARNING:

READ ALL INSTRUCTIONS IN INSTALLATION MANUAL BEFORE INSTALLING AND USING APPLIANCE. FAILURE TO FOLLOW INSTRUCTIONS MAY RESULT IN PROPERTY DAMAGE, BODILY INJURY OR EVEN DEATH.
Installation manual can be found by clicking on this link: www.fornobravo.com/PDF/residential_install.pdf

Side Elevation

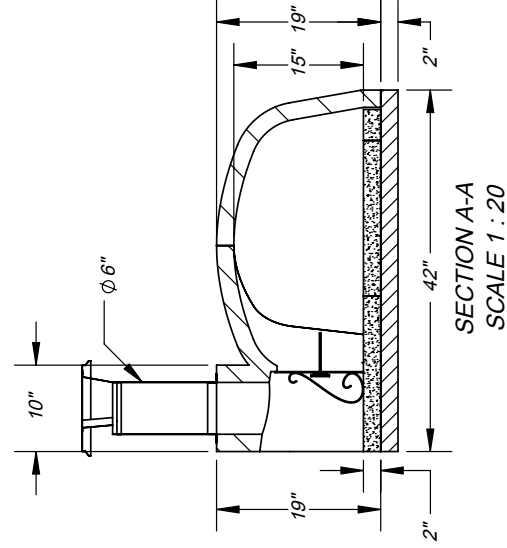

SECTION A-A
SCALE 1 : 20

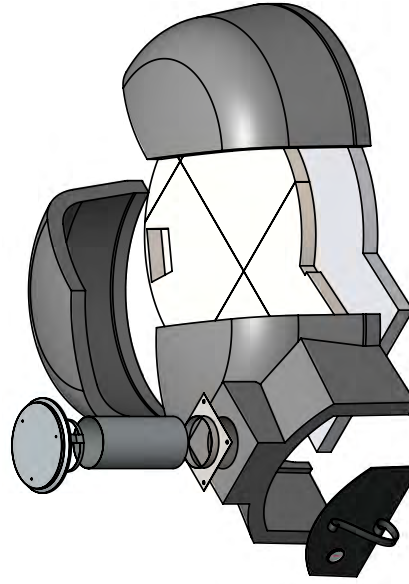

Top View

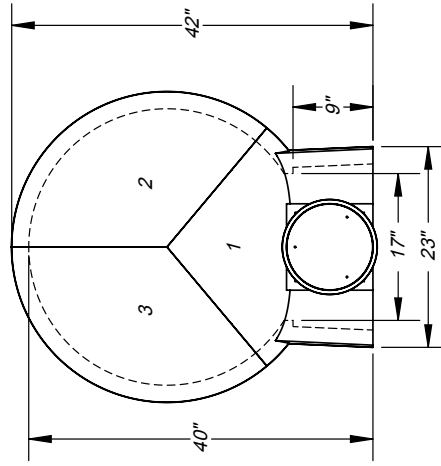

Made in the U.S.A. Residential Gas Fired Pizza Oven

FORNO BRAVO®
THE WORLD'S FINEST PIZZA OVENS

Casa2G 80G
Gas Fired Pizza Oven
Architect Drawings

Revision 6/13/2016 Sheet: 6 of 7



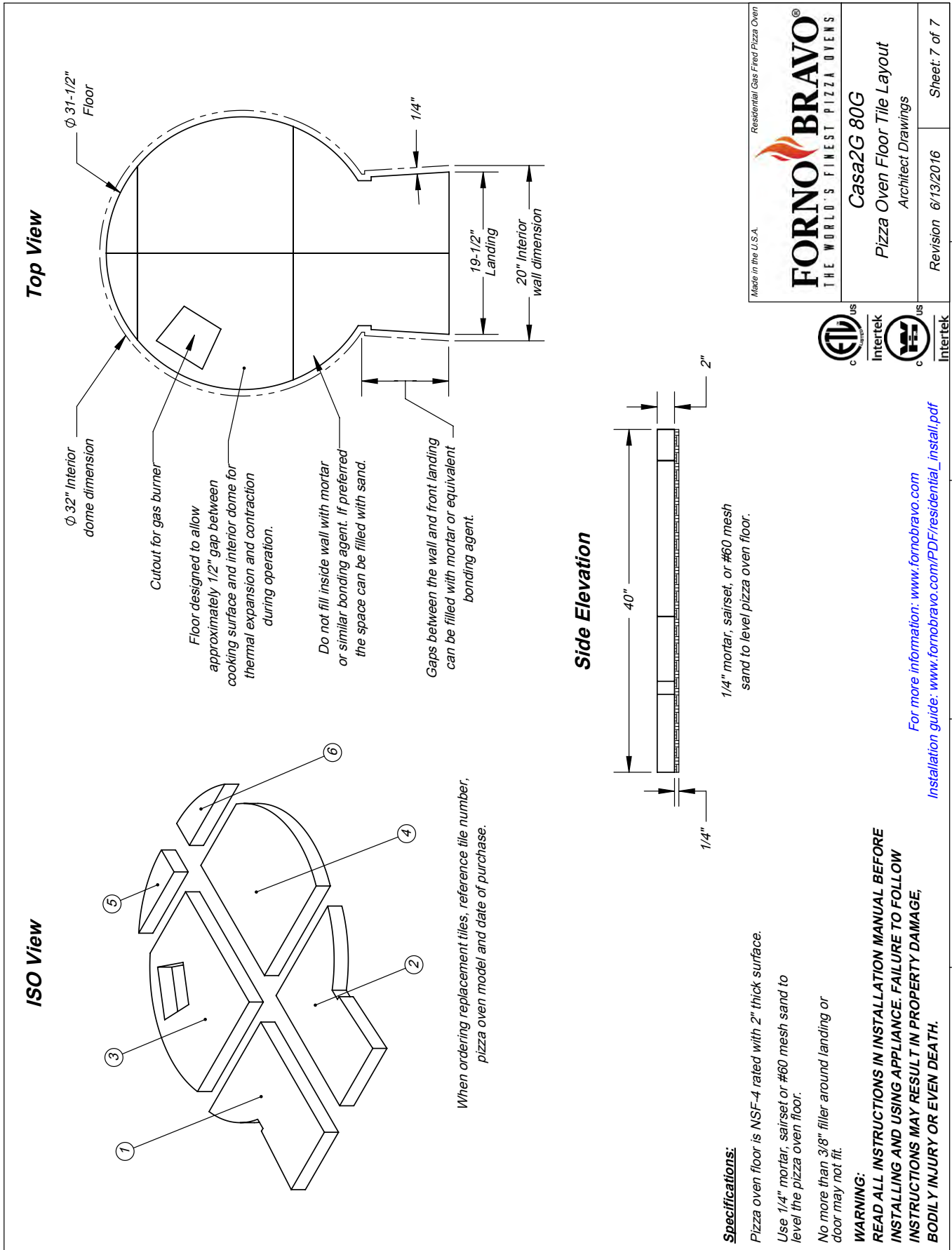

Made in the U.S.A.

FORNO BRAVO®
 THE WORLD'S FINEST PIZZA OVENS

Residential Gas Fired Pizza Oven

Casa2G 80G

Pizza Oven Floor Tile Layout
 Architect Drawings

Revision 6/13/2016

Sheet: 7 of 7



1 2 3 4 5

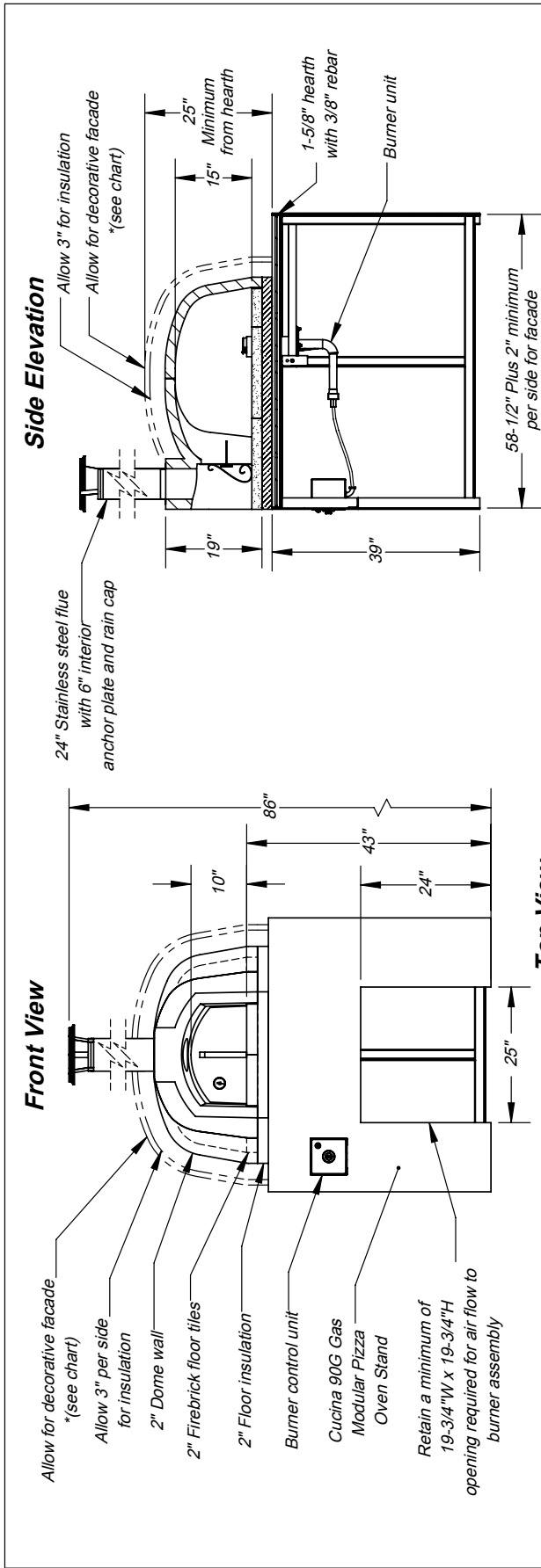

Shown with Forno Bravo Cucina 90G oven stand with non-combustible hearth

Gas Requirements:

Refer to Gas Burner Drawing for air and access requirements

Clearance to combustibles:

- 1" clearance all the way around side walls;
- 14" above completed dome assembly;
- 30" Side clearance from door opening;
- 36" from front of oven landing to combustibles.
- Non-combustible hearth.

Specifications:

- Wood, liquid gas or propane fuel;
- 24" Stainless steel flue with 6" interior, rain cap and anchor plate comes standard.
- Crate ships 54"W x 62"L x 49"H;
- Oven and stand weight: 1510 lbs..

WARNING:

READ ALL INSTRUCTIONS IN INSTALLATION MANUAL BEFORE INSTALLING AND USING APPLIANCE. FAILURE TO FOLLOW INSTRUCTIONS MAY RESULT IN PROPERTY DAMAGE, BODILY INJURY OR EVEN DEATH.

Made in the U.S.A.		Residential Gas Fired Pizza Oven	
FORNO BRAVO® THE WORLD'S FINEST PIZZA OVENS		Casa2G 90G	
Gas Fired Pizza Oven w/ Stand		Architect Drawings SKU: FC2G90-SS-LPING	
Revision 6/13/2016		Sheet: 1 of 7	
Decorative Facade Allowances	Depth	Width	
Brick Arch	Usually 5"	N/A	
Brick Landing	Usually 8"	Preference	
Situcco	Approx 1"	N/A	
Tile	Approx 1"	Approx 2"	
US Stone/Brick Veneer	Approx 1"	N/A	
Brick or Masonry non veneer	Check Material Spec	N/A	
UL737, UL2162, NSF-4, CAN/CGA-1.8 Dual, ANSI-Z83.11 Dual, ANSI Z21.58, CSA 1.6-2007 Listed			
For more information: www.fornobravo.com			
Installation guide: www.fornobravo.com/PDF/residential_install.pdf			

Detailed view of burner placement
SCALE 1:4

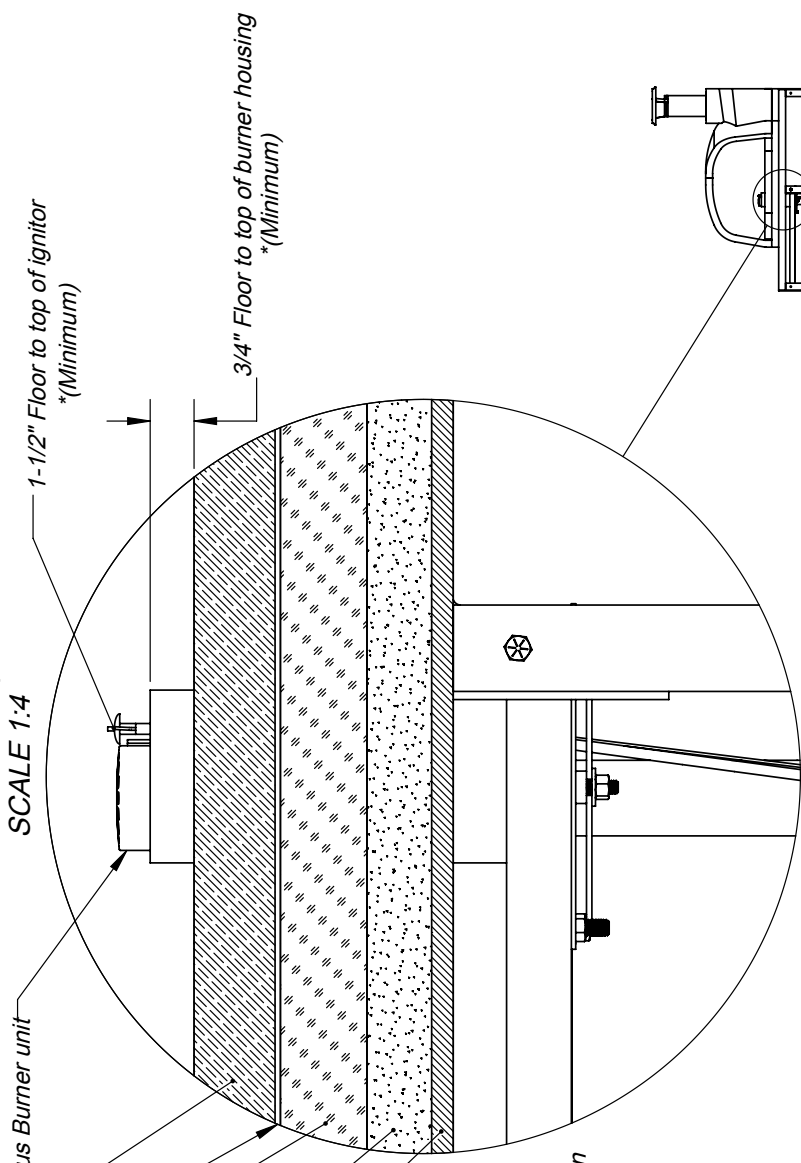

- Drago P1 Plus Burner unit
- 2" Firebrick tiles
- 1/8" - 3/8" Mortar, sairset, or #60 sand used for leveling floor
- 2" Ceramic board floor insulation
- 1-5/8" Concrete hearth with rebar
- 1/2" Backer board

Specifications:

Cucina stand, concrete CMU stand, or equivalent non-combustible structure's front opening requires a minimum of 19-3/4"W x 19-3/4"H for air flow to burner assembly

Gas line should be 1/2" pipe then reduced to 3/8" union

Liquid Propane line pressure 10 to 12 WC

Natural Gas line pressure 5 to 10 WC

Factory settings:

- Natural Gas - 2.75 orifice, air shutter at #2 position
- Liquid Propane - 2.25 orifice, air shutter at #3 position

WARNING: DO NOT CHANGE FACTORY SETTINGS WITHOUT CONSULTING MANUFACTURER OR CERTIFIED TECHNICIAN.

WARNING: READ ALL INSTRUCTIONS IN INSTALLATION MANUAL BEFORE INSTALLING AND USING APPLIANCE. FAILURE TO FOLLOW INSTRUCTIONS MAY RESULT IN PROPERTY DAMAGE, BODILY INJURY OR EVEN DEATH.

UL approved settings for gas orifices	
NG	LP
Input rate w/ 2.5 orifice and air shutter at #2 setting (Btu/hr)	32000
Input rate w/ 2.7 orifice and air shutter at #2 setting (Btu/hr)	38000
Input rate w/ 1.75 orifice and air shutter at #3 setting (Btu/hr)	32000
Input rate w/ 2.0 orifice and air shutter at #3 setting (Btu/hr)	43000
Input rate w/ 2.25 orifice and air shutter at #3 setting (Btu/hr)	51000
Input rate w/ 2.5 orifice and air shutter at #4 setting (Btu/hr)	46000

For more information: www.fornobravo.com

Installation guide: www.fornobravo.com/PDF/residential_install.pdf

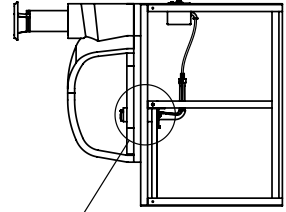

Forno Bravo Casa2G 90G Pizza Oven
and Cucina 90G Modular Pizza Oven Stand

Made in the U.S.A. Residential Gas Fired Pizza Oven



Casa2G 90G
Gas Burner Detailed View
Architect Drawings

Revision 6/13/2016 Sheet: 2 of 7



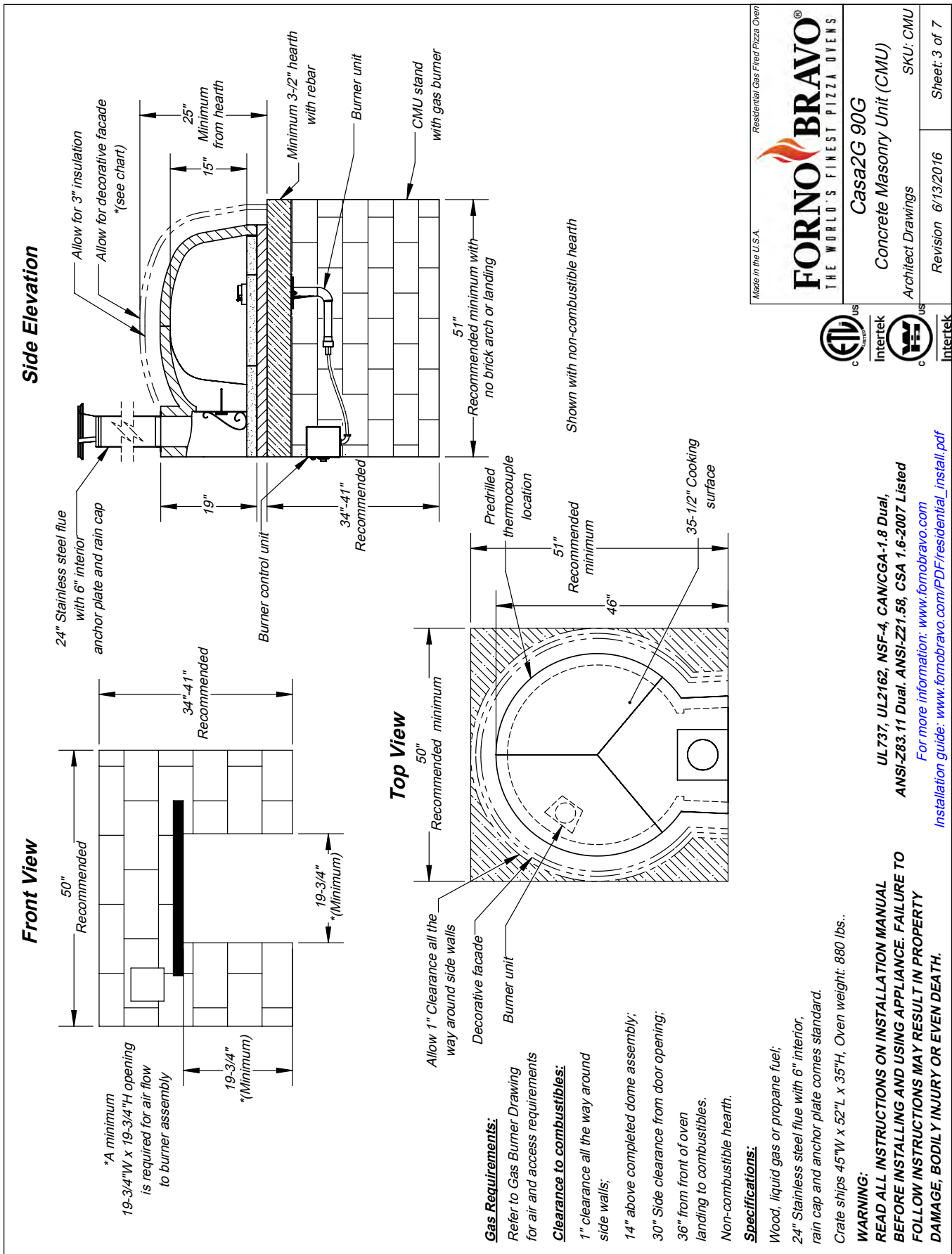

Made in the U.S.A.

Residential Gas Fired Pizza Oven

FORNO BRAVO®
 THE WORLD'S FINEST PIZZA OVENS

Casa2G 90G

Concrete Masonry Unit (CMU)

Architect Drawings

Revision 6/13/2016

SKU: CMU

Sheet: 3 of 7



UL737, UL2162, NSF-4, CAN/CGA-1.8 Dual, ANSI-Z83.11 Dual, ANSI-Z21.58, CSA 1.6-2007 Listed

For more information: www.fornobravo.com

Installation guide: www.fornobravo.com/PDF/residential_install.pdf

ISO View

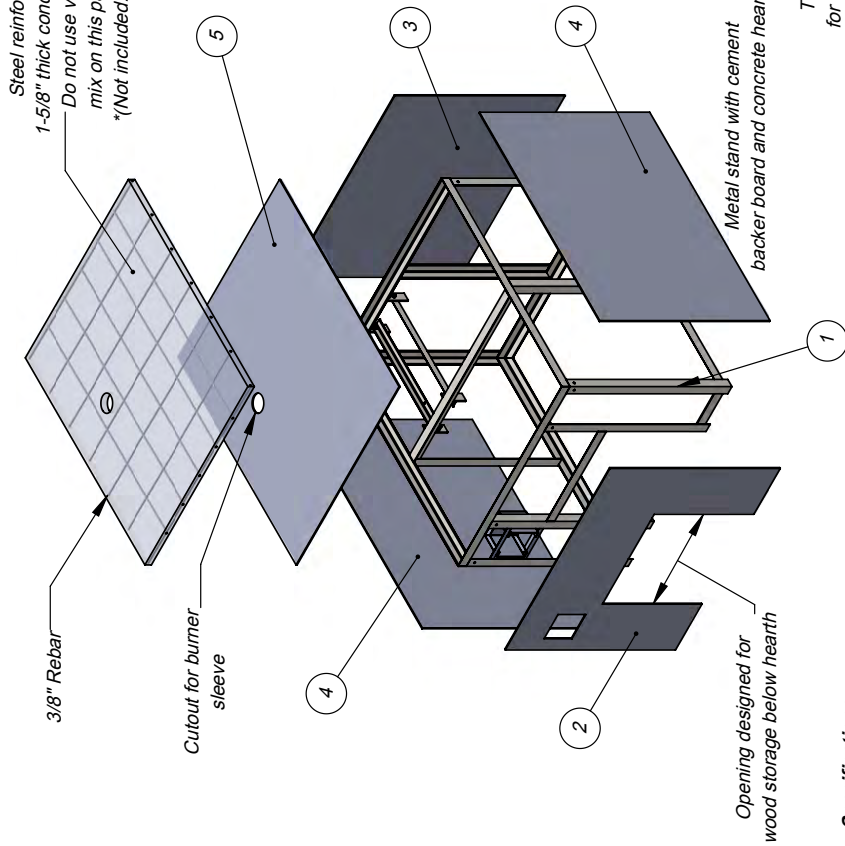

Specifications:

Stand includes metal frame, assembly hardware, pre-cut / predrilled exterior cement backer board panels.

The Cucina 90G stand works with Casa2G 90G oven.

* Hearth materials not included. See installation guide.

WARNING:

READ ALL INSTRUCTIONS IN INSTALLATION MANUAL BEFORE INSTALLING AND USING APPLIANCE. FAILURE TO FOLLOW INSTRUCTIONS MAY RESULT IN PROPERTY DAMAGE, BODILY INJURY OR EVEN DEATH.

For more information: www.fornobravo.com

Installation guide: www.fornobravo.com/PDF/residential_install.pdf

Front View

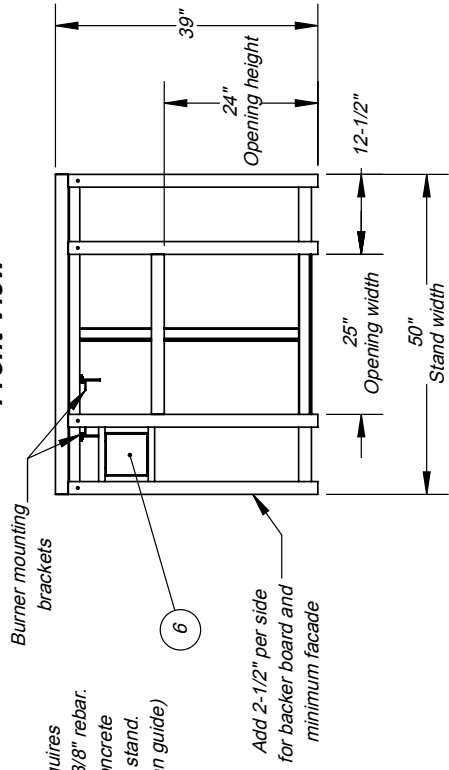

Side Elevation

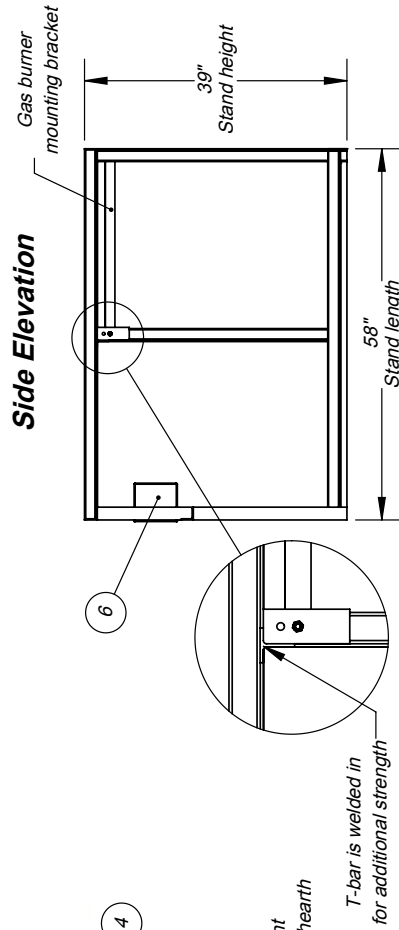

DETAIL A
SCALE 1 : 10

ITEM#	PART NAME	DESCRIPTION	QTY
1	Cucina2G 90G	Metal frame substructure	1
2	Front Panel	1/4" Pre-cut Backer Board	1
3	Back Panel	1/4" Pre-cut Backer Board	1
4	Side Panel	1/4" Pre-cut Backer Board	2
5	Top Panel	1/2" Pre-cut Backer Board	1
6	Control Box Mount	Secures burner control unit	1
7	Hex Bolt, 3/8" x 1"	*Not displayed	10
8	Hex Nut, 3/8"	*Not displayed	10
9	Self Tapping Screw	*Not displayed	55
	*Concrete Hearth	* See installation guide	
	*Rebar	* See installation guide	



Made in the U.S.A.

FORNO BRAVO®
THE WORLD'S FINEST PIZZA OVENS

Cucina 90G
Gas Fired Pizza Oven Stand
SKU: ICS90G

Architect Drawings
Revision 6/13/2016
Sheet: 4 of 7

ISO View

5-1/2" Reinforced concrete pad

1/2" Rebar

Wire mesh

Top View

60-1/2"

52-1/2"

42-1/2"

50-1/2"

4"

4"

4"

4"

4"

4"

Side Elevation

5-1/2"

2-3/4" Rebar and wire mesh

ISO View

68-1/2"

58-1/2"

4"

Casa2G 90G oven stand footprint
 (*See specifications for CMU stand)

Specifications:

- Minimum 5-1/2" deep concrete pad;
- Reinforced with 1/2" rebar and wire mesh. * wire mesh is not shown in some views for print clarity;
- Cut rebar and wire mesh short to conceal inside concrete pad;
- *CMU stand requires a minimum cement foundation pad of 58"W x 61"D

Slab dimensions:

- Minimum 8" wider than oven stand and hearth;
- Minimum 10" deeper than oven stand and hearth;
- Finished slab should be 2" to 3" above ground level;

Refer to local building codes for recommendations regarding soil compaction, frost line and other considerations. Depending on local conditions, you may have to excavate down 18" or more of topsoil to reach stable substrate.

WARNING:
READ ALL INSTRUCTIONS IN INSTALLATION MANUAL BEFORE INSTALLING AND USING APPLIANCE. FAILURE TO FOLLOW INSTRUCTIONS MAY RESULT IN PROPERTY DAMAGE, BODILY INJURY OR EVEN DEATH.

Made in the U.S.A.

Residential Gas Fired Pizza Oven

FORNO BRAVO®
 THE WORLD'S FINEST PIZZA OVENS

Casa2G 90G
 Gas Fired Pizza Oven Pad
 Architect Drawings

Revision 6/13/2016

Sheet 5 of 7

ETL Intertek
 ETL Intertek

For more information: www.fornobravo.com
 Installation guide: www.fornobravo.com/PDF/residential_install.pdf

Side Elevation

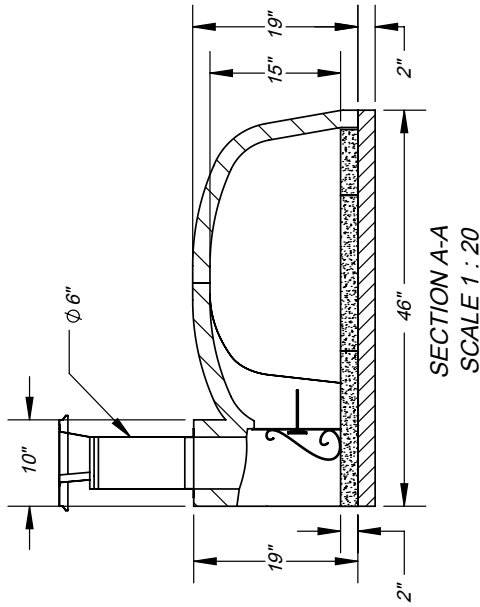

SECTION A-A
SCALE 1 : 20

Front View

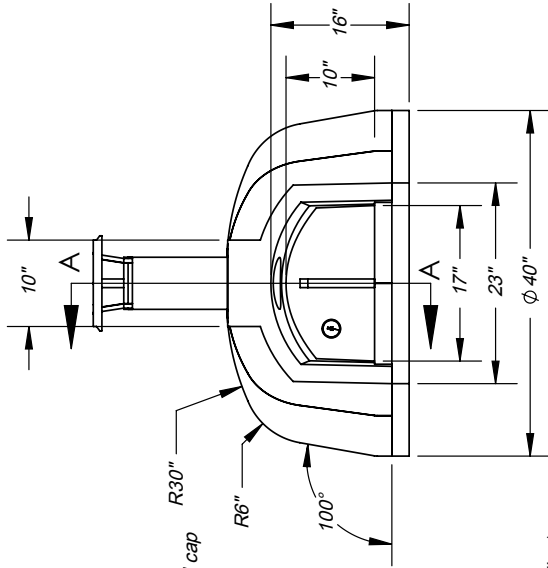

Top View

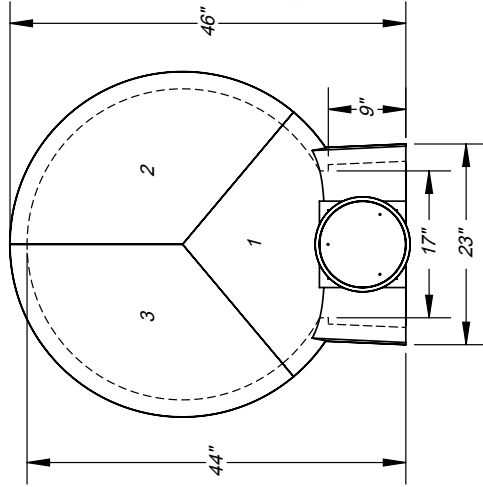

Casa2G 90G Pizza Oven Kit includes:

- Commercial grade refractory oven dome with integral vent
- 2" ceramic fiber insulation board
- 3" ceramic fiber insulation blanket (multiple 1" thick blankets)
- NSF-4 rated fireclay cooking surface
- High temp refractory mortar to seal dome joints
- Single wall stove pipe, anchor plate, 24" pipe and cap
- Single wall steel powder coated door
- Door thermometer

Home Gas Features includes:

- Fuel: Wood, liquid propane or natural gas
- Drago P1 Plus burner assembly (specify, natural gas or liquid propane)
- Burner ignition box with four settings (off, pilot, low and high flame)
- Stainless steel ash guard for burner
- Remote thermometer
- Gas leak detector
- Propane Gas valve regulator. *(Note: Natural gas regulator must be supplied by local certified installer.)

Sold separately:

- UL certified spark arrester
- Decorative brick arch
- Double wall insulated steel door to retain heat longer
- Cucina stand with steel frame and hardie-backer board precut
- Stove pipe extensions
- Upgrade to double wall chimney for indoor installations / covered patios
- Pizza Oven Tools, infrared thermometer, gloves and other items

To be provided by customer / contractor:

- Concrete support pad with rebar (or equivalent structure)
- Concrete masonry stand (CMU) or equivalent non-combustible structure
- Decorative facade materials (stucco, brick, tile, steel, etc.)

Certifications:

Tested and compliant with:
UL737, UL2162, NSF-4, CAN/CGA-1.8 Dual, ANSI-Z83.11 Dual, ANSI-Z21.58-CSA 1.6-2007
For more information about our certifications, click here: www.fornobravo.com/ul-certified

WARNING:

READ ALL INSTRUCTIONS IN INSTALLATION MANUAL BEFORE INSTALLING AND USING APPLIANCE. FAILURE TO FOLLOW INSTRUCTIONS MAY RESULT IN PROPERTY DAMAGE, BODILY INJURY OR EVEN DEATH
Installation manual can be found by clicking on this link: www.fornobravo.com/PDF/residential_install.pdf

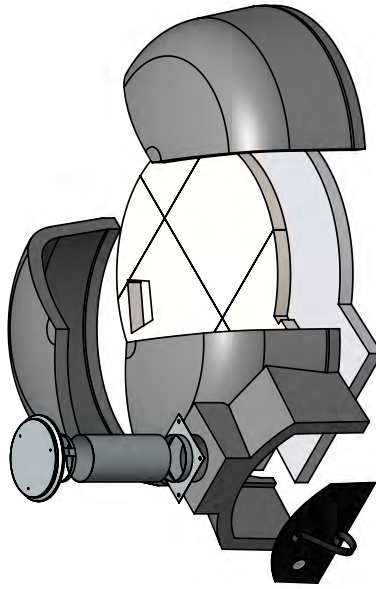

Made in the U.S.A.

Residential Gas Fired Pizza Oven

FORNO BRAVO®
THE WORLD'S FINEST PIZZA OVENS

Casa2G 90G
Gas Fired Pizza Oven
Architect Drawings

Revision 6/13/2016

Sheet: 6 of 7



1 2 3 4 5

ISO View

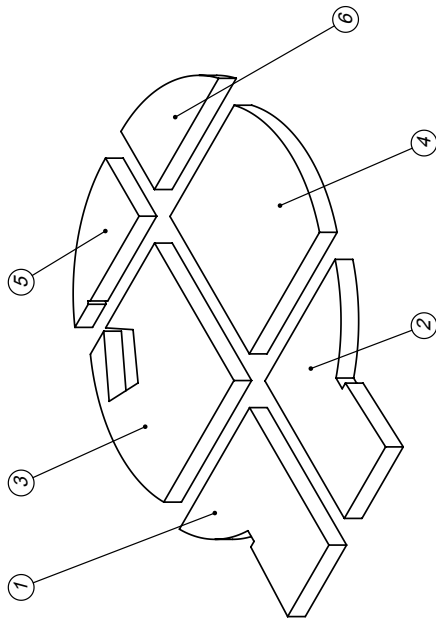

Top View

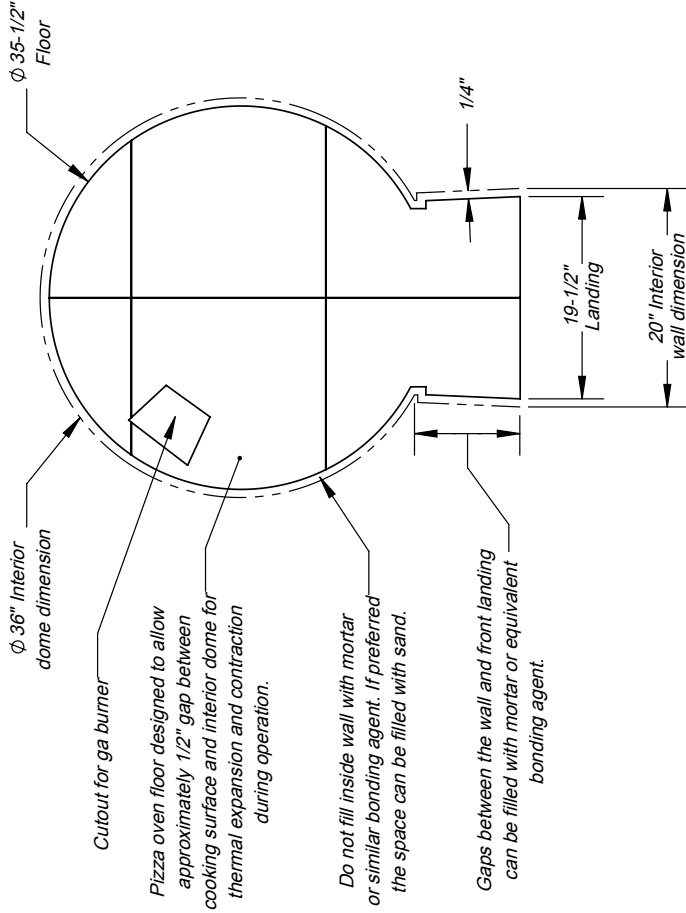

Side Elevation

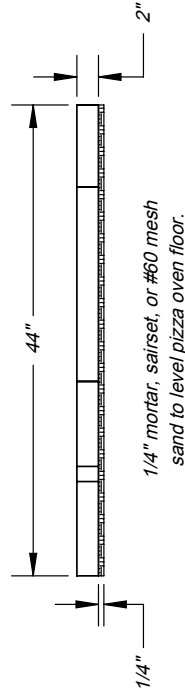

When ordering replacement tiles, reference tile number, pizza oven model and date of purchase.

Specifications:

Pizza oven floor is NSF-4 rated with 2" thick surface.

Use 1/4" mortar, salsset, or #60 mesh sand to level the floor.

No more than 3/8" filler around landing or door may not fit.

WARNING:
 READ ALL INSTRUCTIONS IN INSTALLATION MANUAL BEFORE INSTALLING AND USING APPLIANCE. FAILURE TO FOLLOW INSTRUCTIONS MAY RESULT IN PROPERTY DAMAGE, BODILY INJURY OR EVEN DEATH.

Made in the U.S.A. Residential Gas Fired Pizza Oven

FORNO BRAVO®
 THE WORLD'S FINEST PIZZA OVENS

Casa2G 90G
 Pizza Oven Floor Tile Layout
 Architect Drawings

Revision 6/13/2016 Sheet: 7 of 7



For more information: www.fornobravo.com
 Installation guide: www.fornobravo.com/PDF/residential_install.pdf

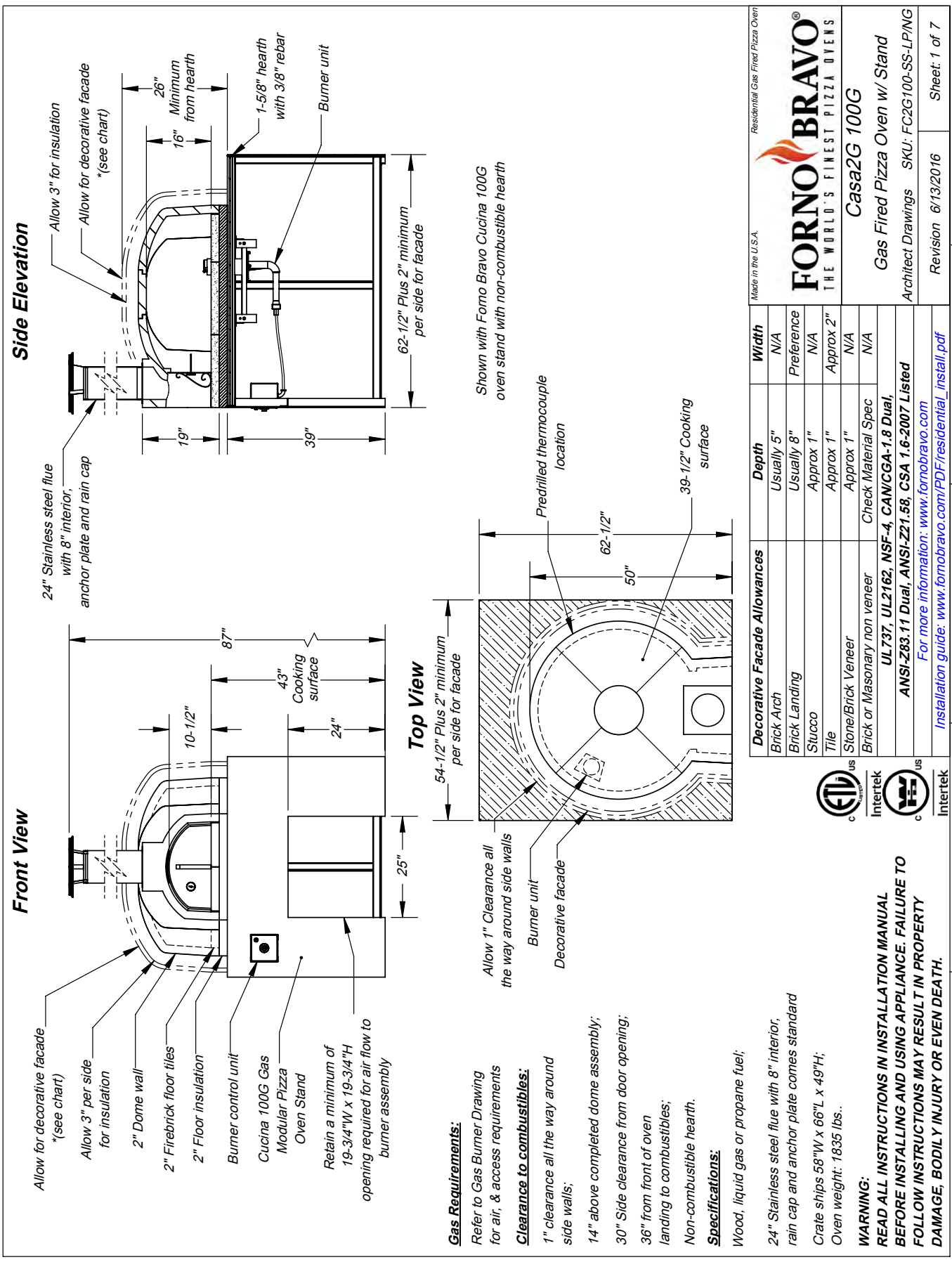

Front View

Side Elevation

Top View

Allow for decorative facade *(see chart)
 Allow 3" per side for insulation
 2" Dome wall
 2" Firebrick floor tiles
 2" Floor insulation
 Burner control unit
 Cucina 100G Gas Modular Pizza Oven Stand
 Retain a minimum of 19-3/4"W x 19-3/4"H opening required for air flow to burner assembly

24" Stainless steel flue with 8" interior, anchor plate and rain cap
 Allow 3" for insulation *(see chart)
 26" Minimum from hearth
 1-5/8" hearth with 3/8" rebar
 Burner unit
 62-1/2" Plus 2" minimum per side for facade

87"
 10-1/2"
 43" Cooking surface
 24"
 25"
 54-1/2" Plus 2" minimum per side for facade
 50"
 62-1/2"
 39-1/2" Cooking surface
 Predrilled thermocouple location

Gas Requirements:

Refer to Gas Burner Drawing for air, & access requirements

Clearance to combustibles:

- 1" clearance all the way around side walls;
- 14" above completed dome assembly;
- 30" Side clearance from door opening;
- 36" from front of oven landing to combustibles;
- Non-combustible hearth.

Specifications:

- Wood, liquid gas or propane fuel;
- 24" Stainless steel flue with 8" interior, rain cap and anchor plate comes standard
- Crate ships 58"W x 66"L x 49"H;
- Oven weight: 1835 lbs..

WARNING:

READ ALL INSTRUCTIONS IN INSTALLATION MANUAL BEFORE INSTALLING AND USING APPLIANCE. FAILURE TO FOLLOW INSTRUCTIONS MAY RESULT IN PROPERTY DAMAGE, BODILY INJURY OR EVEN DEATH.

Made in the U.S.A.		Residential Gas Fired Pizza Oven	
		Width	N/A
		Depth	Usually 5" Preference Approx 1" Approx 1" Approx 1"
Decorative Facade Allowances	Brick Arch Brick Landing Stucco Tile Stone/Brick Veneer Brick or Masonry non veneer	Depth	Check Material Spec UL737, UL2162, NSF-4, CAN/CGA-1.8 Dual, ANSI-Z83.11 Dual, ANSI-Z21.58, CSA 1.6-2007 Listed For more information: www.fornobravo.com Installation guide: www.fornobravo.com/PDF/residential_install.pdf
		Width	N/A
		Depth	Check Material Spec UL737, UL2162, NSF-4, CAN/CGA-1.8 Dual, ANSI-Z83.11 Dual, ANSI-Z21.58, CSA 1.6-2007 Listed For more information: www.fornobravo.com Installation guide: www.fornobravo.com/PDF/residential_install.pdf
Casa2G 100G Gas Fired Pizza Oven w/ Stand Architect Drawings SKU: FC2G100-SS-LPING Revision 6/13/2016		Width	N/A
Sheet: 1 of 7		Depth	Approx 1"

Detailed view of burner placement
 SCALE 1:4

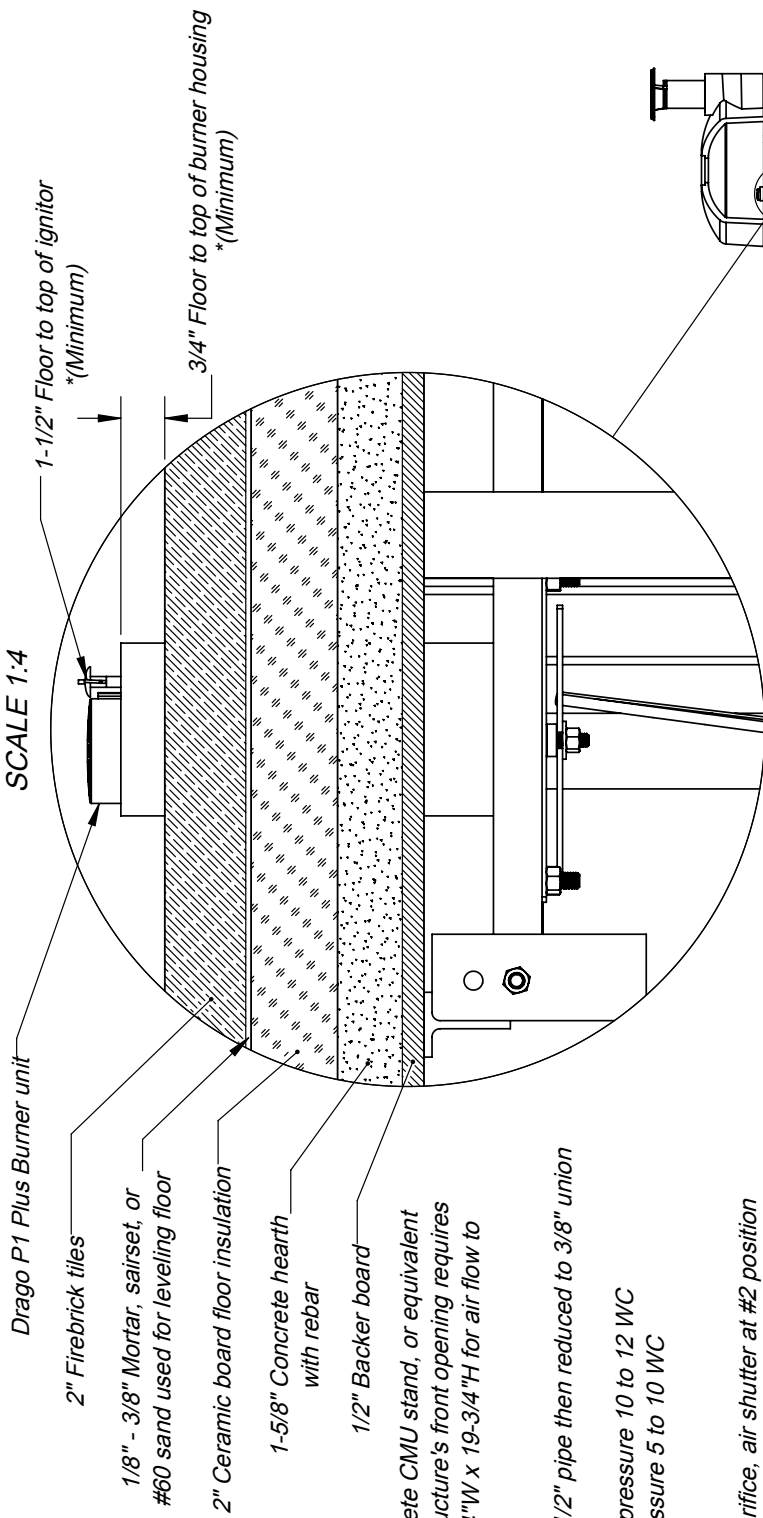

- Drago P1 Plus Burner unit
- 2" Firebrick tiles
- 1/8" - 3/8" Mortar, salsiset, or #60 sand used for leveling floor
- 2" Ceramic board floor insulation
- 1-5/8" Concrete hearth with rebar
- 1/2" Backer board

Specifications:

Cucina stand, concrete CMU stand, or equivalent non-combustible structure's front opening requires a minimum of 19-3/4"W x 19-3/4"H for air flow to burner assembly

Gas line should be 1/2" pipe then reduced to 3/8" union

Liquid Propane line pressure 10 to 12 WC

Natural Gas line pressure 5 to 10 WC

Factory settings:

Natural Gas - 2.75 orifice, air shutter at #2 position

Liquid Propane - 2.25 orifice, air shutter at #3 position

WARNING: DO NOT CHANGE FACTORY SETTINGS WITHOUT CONSULTING MANUFACTURER OR CERTIFIED TECHNICIAN.

WARNING: READ ALL INSTRUCTIONS IN INSTALLATION MANUAL BEFORE INSTALLING AND USING APPLIANCE. FAILURE TO FOLLOW INSTRUCTIONS MAY RESULT IN PROPERTY DAMAGE, BODILY INJURY OR EVEN DEATH.

UL approved settings for gas orifices		NG	LP
Input rate w/ 2.5 orifice and air shutter at #2 setting (Btu/hr)		32000	
Input rate w/ 2.7 orifice and air shutter at #2 setting (Btu/hr)		38000	
Input rate w/ 1.75 orifice and air shutter at #3 setting (Btu/hr)			32000
Input rate w/ 2.0 orifice and air shutter at #3 setting (Btu/hr)			43000
Input rate w/ 2.25 orifice and air shutter at #3 setting (Btu/hr)			51000
Input rate w/ 2.5 orifice and air shutter at #4 setting (Btu/hr)			46000

For more information: www.fornobravo.com

Installation guide: www.fornobravo.com/PDF/residential_install.pdf

Forno Bravo Casa2G 100G Pizza Oven
 and Cucina 100G Modular Pizza Oven Stand

Made in the U.S.A.

Residential Gas Fired Pizza Oven



FORNO BRAVO
 THE WORLD'S FINEST PIZZA OVENS

Casa2G 100G

Gas Burner Detailed View

Architect Drawings

Revision 6/13/2016

Sheet: 2 of 7

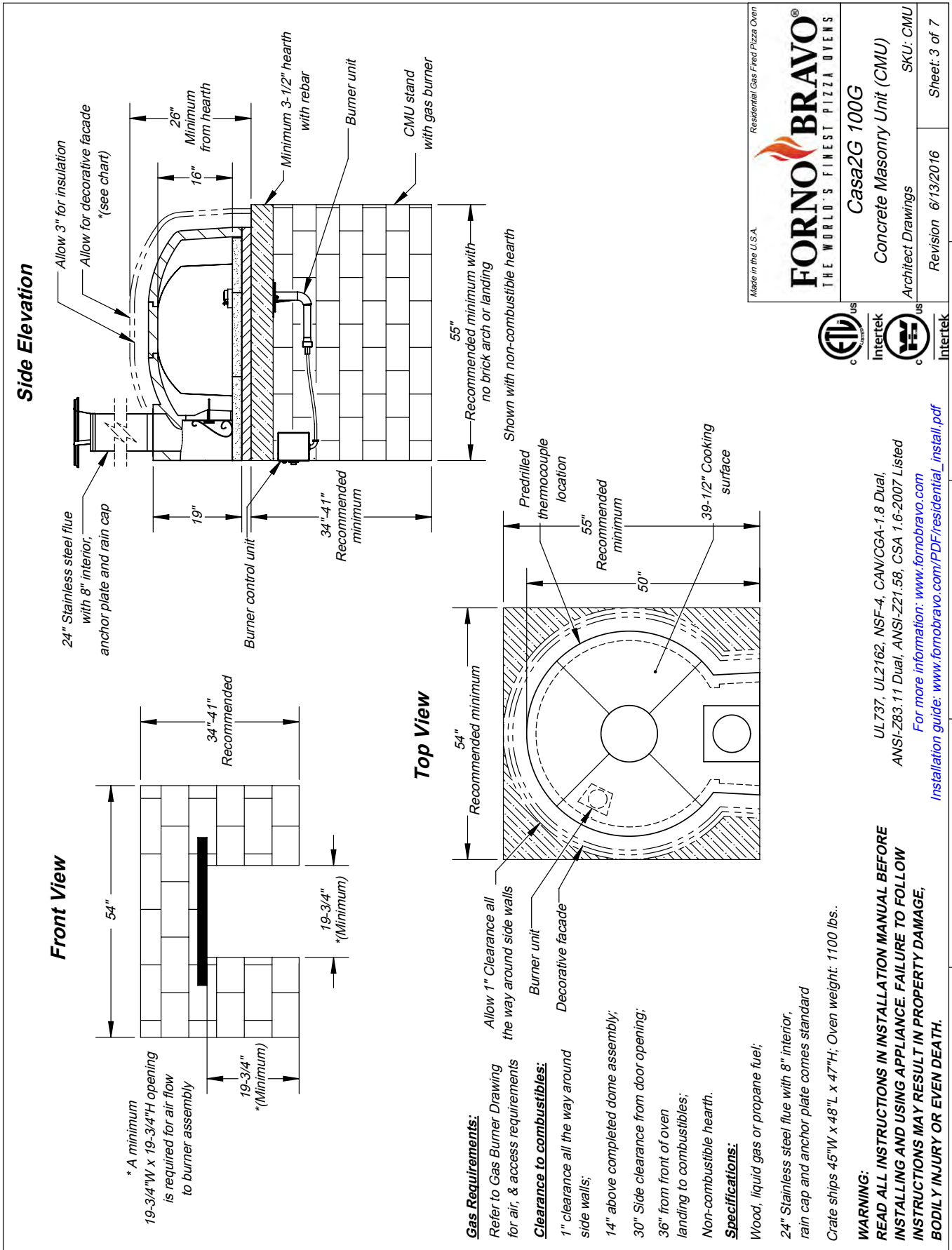

Made in the U.S.A. Residential Gas Fired Pizza Oven

FORNO BRAVO®
 THE WORLD'S FINEST PIZZA OVENS

Casa2G 100G
 Concrete Masonry Unit (CMU)
 Architect Drawings SKU: CMU
 Revision 6/13/2016 Sheet: 3 of 7



UL737, UL2162, NSF-4, CAN/CGA-1.8 Dual, ANSI-Z83.11 Dual, ANSI-Z21.58, CSA 1.6-2007 Listed
 For more information: www.fornobravo.com
 Installation guide: www.fornobravo.com/PDF/residential_install.pdf

ISO View

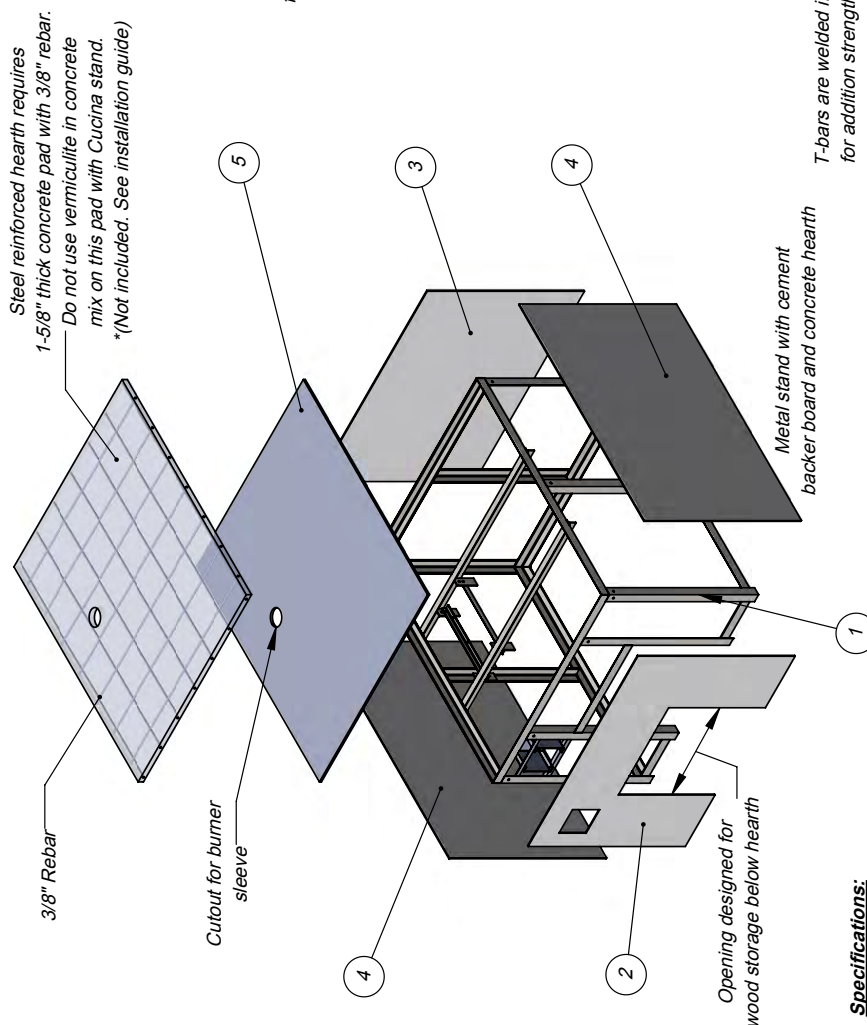

Specifications:

Stand includes metal frame, assembly hardware, pre-cut / pre-drilled exterior cement backer board panels.

The Cucina 100G stand works with Casa2G 100G oven.

* Hearth materials not included. See installation guide.

WARNING:
READ ALL INSTRUCTIONS IN INSTALLATION MANUAL BEFORE INSTALLING AND USING APPLIANCE. FAILURE TO FOLLOW INSTRUCTIONS MAY RESULT IN PROPERTY DAMAGE, BODILY INJURY OR EVEN DEATH.

For more information: www.fornobravo.com
 Installation guide: www.fornobravo.com/PDF/residential_install.pdf



Front View

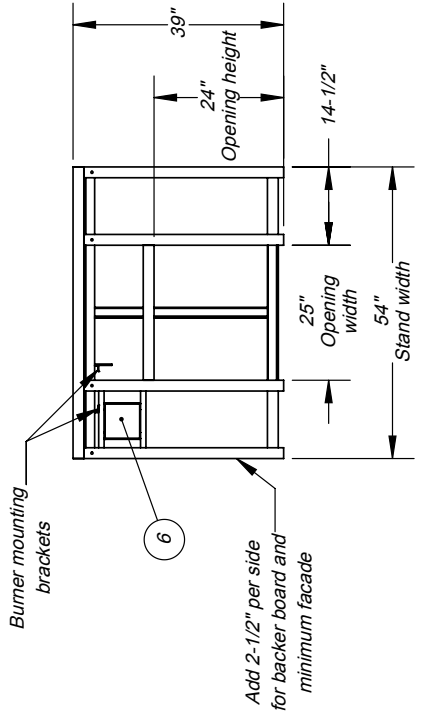

Side Elevation

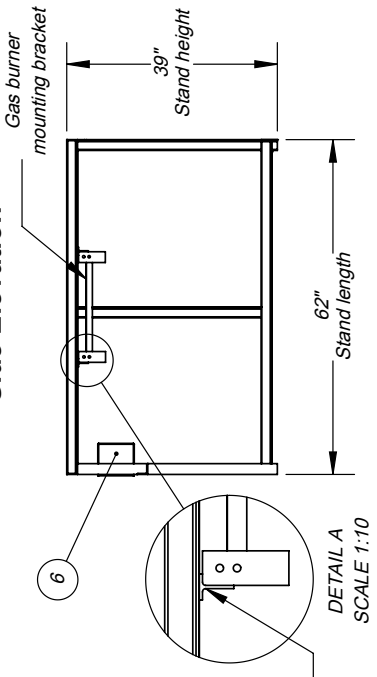

ITEM#	PART NAME	DESCRIPTION	QTY
1	Cucina2G 100G	Metal frame substructure	1
2	Front Panel	1/4" Pre-cut Backer Board	1
3	Back Panel	1/4" Pre-cut Backer Board	1
4	Side Panel	1/4" Pre-cut Backer Board	2
5	Top Panel	1/2" Pre-cut Backer Board	1
6	Control Box Mount	Secures burner control unit	1
7	Hex Bolt, 3/8" x 1"	*Not displayed	10
8	Hex Nut, 3/8"	*Not displayed	10
9	Self Tapping Screw	*Not displayed	55
	*Concrete Hearth	* See installation guide	
	*Rebar	* See installation guide	

Made in the U.S.A.
 Residential Gas Fired Pizza Oven
FORNO BRAVO®
 THE WORLD'S FINEST PIZZA OVENS

Cucina 100G
 Gas Fired Pizza Oven Stand
 Architect Drawings
 Revision 6/13/2016
 SKU: ICS100G
 Sheet: 4 of 7

ISO View

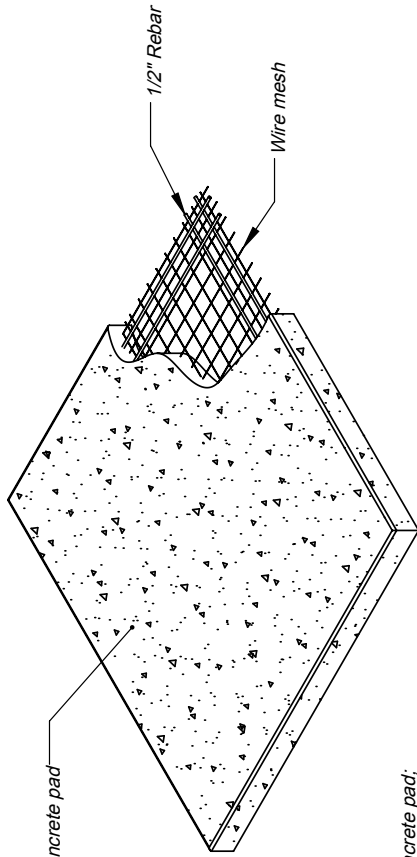

Top View

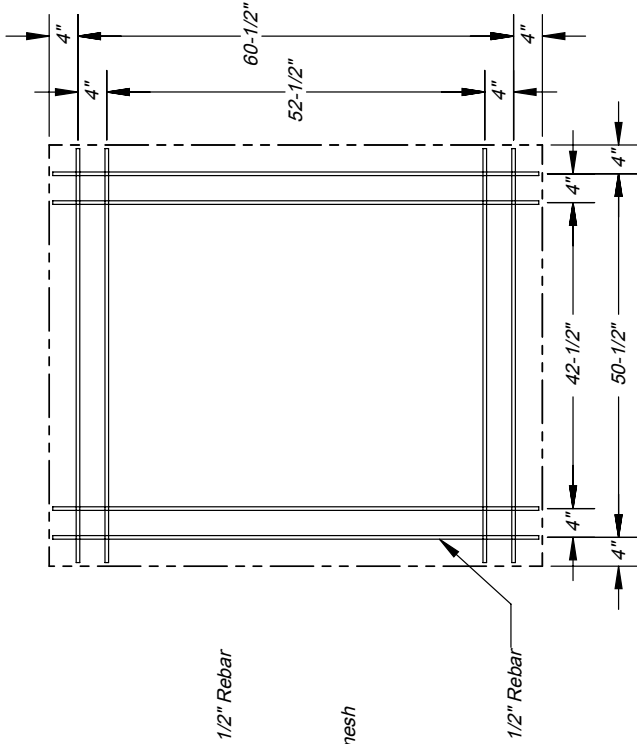

Side Elevation

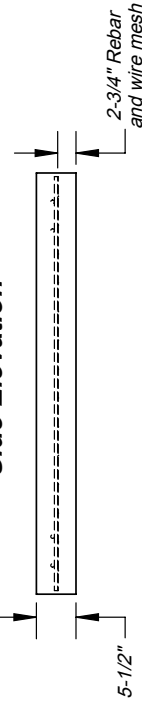

Casa2G 100G oven stand footprint
(*See specifications for CMU stand)

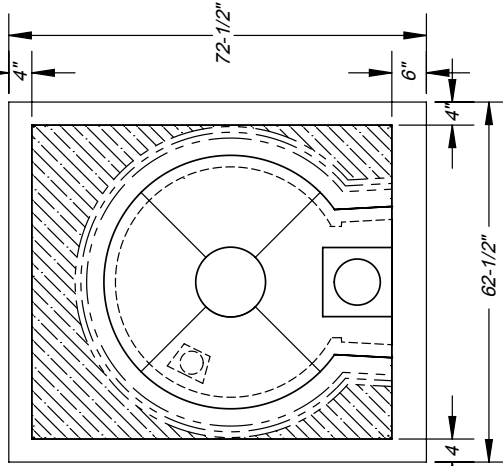

Specifications:

Minimum 5-1/2" deep concrete pad;

Reinforced with 1/2" rebar and wire mesh. * wire mesh is not shown in some views for print clarity;

Cut rebar and wire mesh short to conceal inside concrete pad;

*CMU stand requires a minimum cement foundation pad of 62"W x 65"D

Slab dimensions:

Minimum 8" wider than oven stand and hearth;

Minimum 10" deeper than oven stand and hearth;

Finished slab should be 2" to 3" above ground level;

Refer to local building codes for recommendations regarding soil compaction, frost line and other considerations. Depending on local conditions, you may have to excavate down 18" or more of topsoil to reach stable substrate.

WARNING:
READ ALL INSTRUCTIONS IN INSTALLATION MANUAL BEFORE INSTALLING AND USING APPLIANCE. FAILURE TO FOLLOW INSTRUCTIONS MAY RESULT IN PROPERTY DAMAGE, BODILY INJURY OR EVEN DEATH.

Made in the U.S.A.

FORNO BRAVO®
THE WORLD'S FINEST PIZZA OVENS

Residential Gas Fired Pizza Oven

Casa2G 100G
Gas Fired Pizza Oven Pad

Architect Drawings

Revision 6/13/2016

Sheet: 5 of 7



For more information: www.fornobravo.com
Installation guide: www.fornobravo.com/PDF/residential_install.pdf

Front View

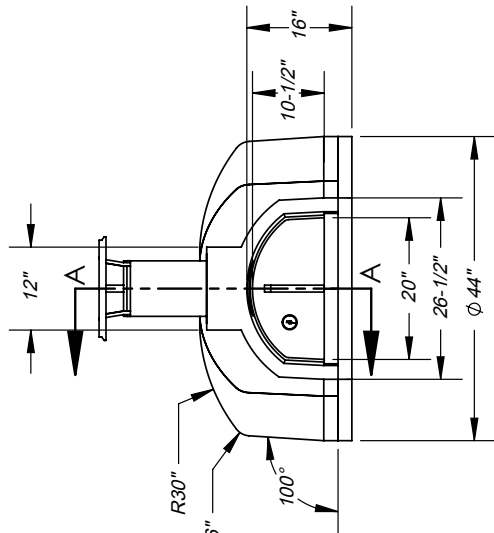

Side Elevation

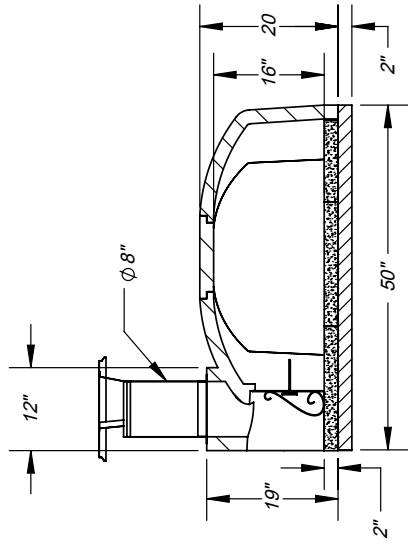

SECTION A-A
 SCALE 1 : 25

Top View

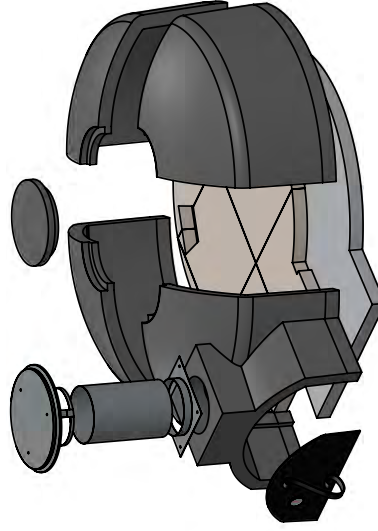
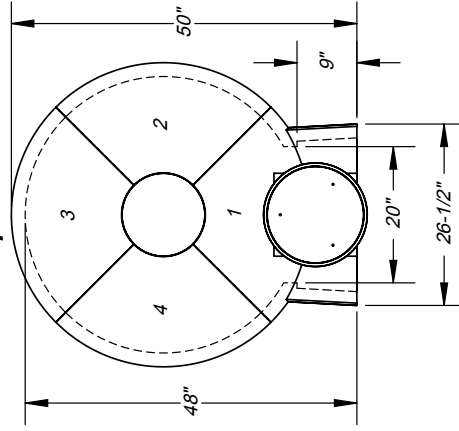

Casa2G 100G Pizza Oven Kit includes:

- Commercial grade refractory oven dome with integral vent
- 2" ceramic fiber insulation board
- 3" ceramic fiber insulation blanket (multiple 1" thick blankets)
- NSF-4 rated fireclay cooking surface
- High temp refractory mortar to seal dome joints
- Single wall stove pipe, anchor plate, 24" pipe and cap
- Single wall steel powder coated door
- Door thermometer

Home Gas Features includes:

- Fuel: Wood, liquid propane or natural gas
- Drago P1 Plus burner assembly (specify, natural gas or liquid propane)
- Burner ignition box with four settings (off, pilot, low and high flame)
- Stainless steel ash guard for burner
- Remote thermometer
- Gas leak detector
- Propane Gas valve regulator. *(Note: Natural gas regulator must be supplied by local certified installer.)

Sold separately:

- UL certified spark arrester
- Decorative brick arch
- Double wall insulated steel door to retain heat longer
- Cucina stand with steel frame and hardie-backer board precut
- Stove pipe extensions
- Upgrade to double wall chimney for indoor installations / covered patios
- Pizza Oven Tools, infrared thermometer, gloves and other items

To be provided by customer / contractor:

- Concrete support pad with rebar (or equivalent structure)
- Concrete masonry stand (CMU) or equivalent non-combustible structure
- Decorative facade materials (stucco, brick, tile, steel, etc.)

Certifications:

Tested and compliant with:
 UL737, UL2162, NSF-4, CAN/CGA-1.8 Dual, ANSI-Z83.11 Dual, ANSI-Z21.58-CSA 1.6-2007
 For more information about our certifications, click here: www.fornobravo.com/ul-certified

WARNING:
READ ALL INSTRUCTIONS IN INSTALLATION MANUAL BEFORE INSTALLING AND USING APPLIANCE.
FAILURE TO FOLLOW INSTRUCTIONS MAY RESULT IN PROPERTY DAMAGE, BODILY INJURY OR EVEN DEATH
 Installation manual can be found by clicking on this link: www.fornobravo.com/PDF/residential_install.pdf

Made in the U.S.A. Residential Gas Fired Pizza Oven

FORNO BRAVO®
 THE WORLD'S FINEST PIZZA OVENS

Casa2G 100G
 Gas Fired Pizza Oven
 Architect Drawings

Revision 6/13/2016 Sheet: 6 of 7



ISO View

When ordering replacement tiles, reference tile number, pizza oven model and date of purchase.

Top View

ϕ 40" Interior dome dimension
 ϕ 39-1/2" Floor
 1/4"
 23" Landing
 23-1/2" Interior wall dimension

Cutout for gas burner
 Pizza oven floor designed to allow approximately 1/2" gap between cooking surface and interior dome for thermal expansion and contraction during operation.
 Do not fill inside wall with mortar or similar bonding agent. If preferred the space can be filled with sand.
 Gaps between the wall and front landing can be filled with mortar or equivalent bonding agent.

Side Elevation

48"
 2"
 1/4" mortar, sairsset, or #60 mesh sand to level pizza oven floor.

Specifications:

Pizza oven floor is NSF-4 rated with 2" thick surface.

Use 1/4" mortar, sairsset, or #60 mesh sand to level the floor.

No more than 3/8" filler around landing or door may not fit.

WARNING:
 READ ALL INSTRUCTIONS IN INSTALLATION MANUAL BEFORE INSTALLING AND USING APPLIANCE. FAILURE TO FOLLOW INSTRUCTIONS MAY RESULT IN PROPERTY DAMAGE, BODILY INJURY OR EVEN DEATH.

For more information: www.fornobravo.com
 Installation guide: www.fornobravo.com/PDF/residential_install.pdf

Made in the U.S.A. Residential Gas Fired Pizza Oven

FORNO BRAVO
 THE WORLD'S FINEST PIZZA OVENS

Casa2G 100G
 Pizza Oven Floor Tile Layout
 Architect Drawings

Revision 6/13/2016 Sheet 7 of 7

1 2 3 4 5

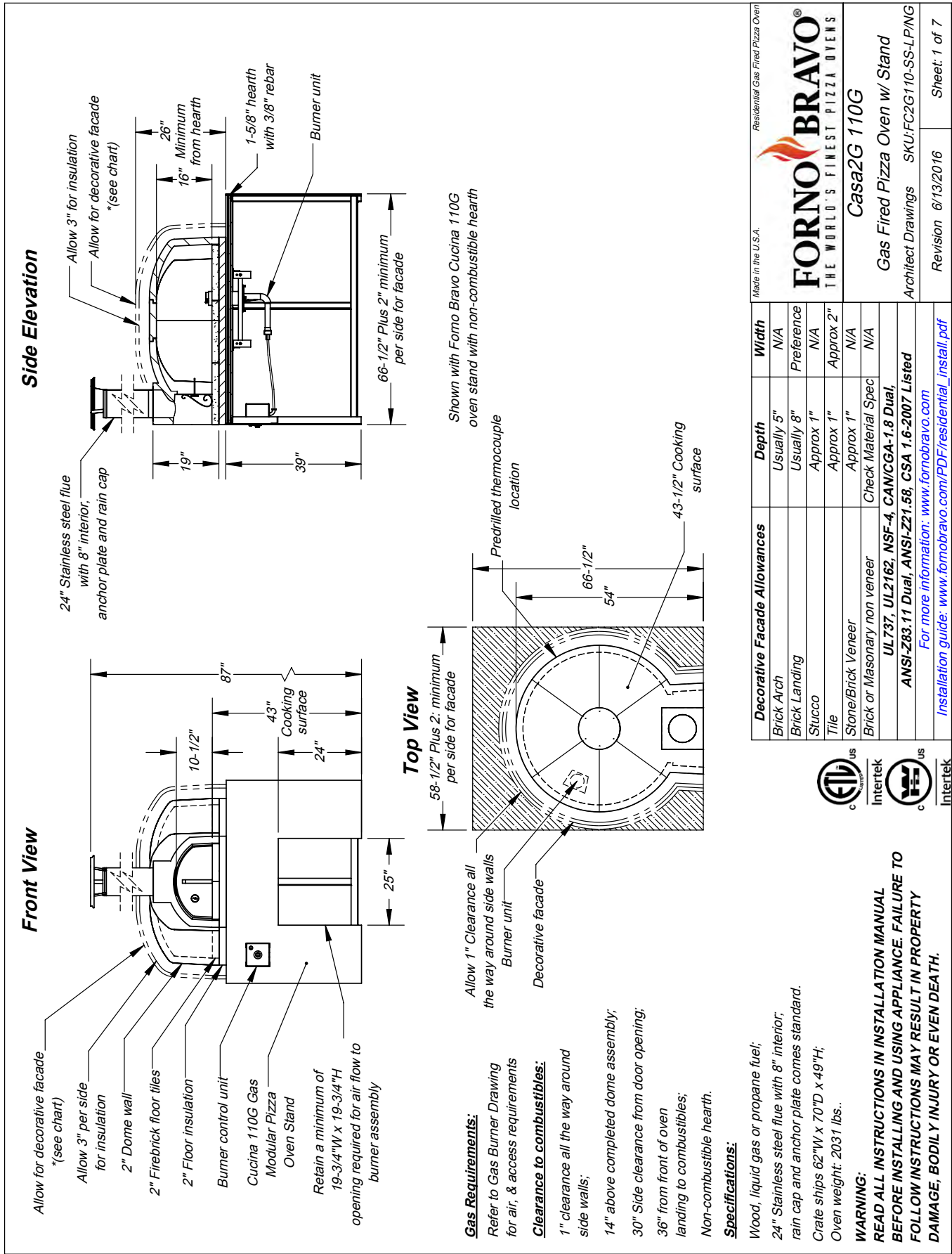

Made in the U.S.A.		Residential Gas Fired Pizza Oven	
FORNO BRAVO® THE WORLD'S FINEST PIZZA OVENS		Casa2G 110G	
Gas Fired Pizza Oven w/ Stand		Architect Drawings SKU:FC2G110-SS-LP/NG	
Revision 6/13/2016		Sheet: 1 of 7	
Decorative Facade Allowances	Depth	Width	
Brick Arch	Usually 5"	N/A	
Brick Landing	Usually 8"	Preference	
Stucco	Approx 1"	N/A	
Tile	Approx 1"	Approx 2"	
Stone/Brick Veneer	Approx 1"	N/A	
Brick or Masonry non veneer	Check Material Spec	N/A	
UL737, UL2162, NSF-4, CAN/CGA-1.8 Dual, ANSI-Z83.11 Dual, ANSI-Z21.58, CSA 1.6-2007 Listed			
For more information: www.fornobravo.com			
Installation guide: www.fornobravo.com/PDF/residential_install.pdf			



Detailed view of burner placement
SCALE 1:4

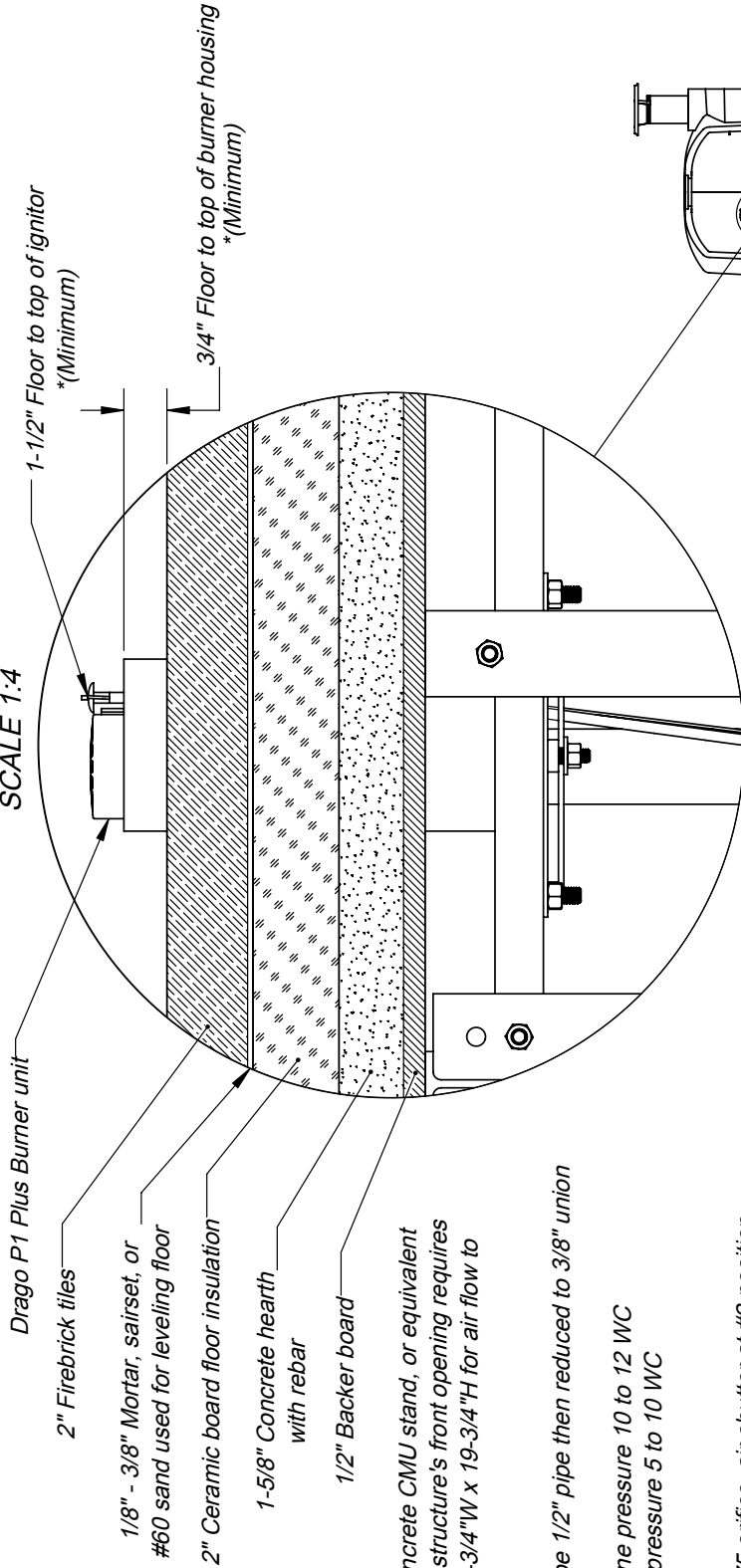

- Drago P1 Plus Burner unit
- 2" Firebrick tiles
- 1/8" - 3/8" Mortar, sarsset, or #60 sand used for leveling floor
- 2" Ceramic board floor insulation
- 1-5/8" Concrete hearth with rebar
- 1/2" Backer board

Specifications:
Cucina stand, concrete CMU stand, or equivalent non-combustible structure's front opening requires a minimum of 19-3/4"W x 19-3/4"H for air flow to burner assembly

Gas line should be 1/2" pipe then reduced to 3/8" union

Liquid Propane line pressure 10 to 12 WC

Natural Gas line pressure 5 to 10 WC

Factory settings:

Natural Gas - 2.75 orifice, air shutter at #2 position

Liquid Propane - 2.25 orifice, air shutter at #3 position

WARNING: DO NOT CHANGE FACTORY SETTINGS WITHOUT CONSULTING MANUFACTURER OR CERTIFIED TECHNICIAN.

WARNING: READ ALL INSTRUCTIONS IN INSTALLATION MANUAL BEFORE INSTALLING AND USING APPLIANCE. FAILURE TO FOLLOW INSTRUCTIONS MAY RESULT IN PROPERTY DAMAGE, BODILY INJURY OR EVEN DEATH.

UL approved settings for gas orifices		NG	LP
Input rate w/ 2.5 orifice and air shutter at #2 setting (Btu/hr)		32000	
Input rate w/ 2.7 orifice and air shutter at #2 setting (Btu/hr)		38000	
Input rate w/ 1.75 orifice and air shutter at #3 setting (Btu/hr)			32000
Input rate w/ 2.0 orifice and air shutter at #3 setting (Btu/hr)			43000
Input rate w/ 2.25 orifice and air shutter at #3 setting (Btu/hr)			51000
Input rate w/ 2.5 orifice and air shutter at #4 setting (Btu/hr)			46000

For more information: www.fornobravo.com

Installation guide: www.fornobravo.com/PDF/residential_install.pdf

Forno Bravo Casa2G 110G Pizza Oven
and Cucina 110G Modular Pizza Oven Stand

Made in the U.S.A.
Residential Gas Fired Pizza Oven



Casa2G 110G	
Gas Burner Detailed View	
Architect Drawings	
Revision 6/13/2016	Sheet: 2 of 7



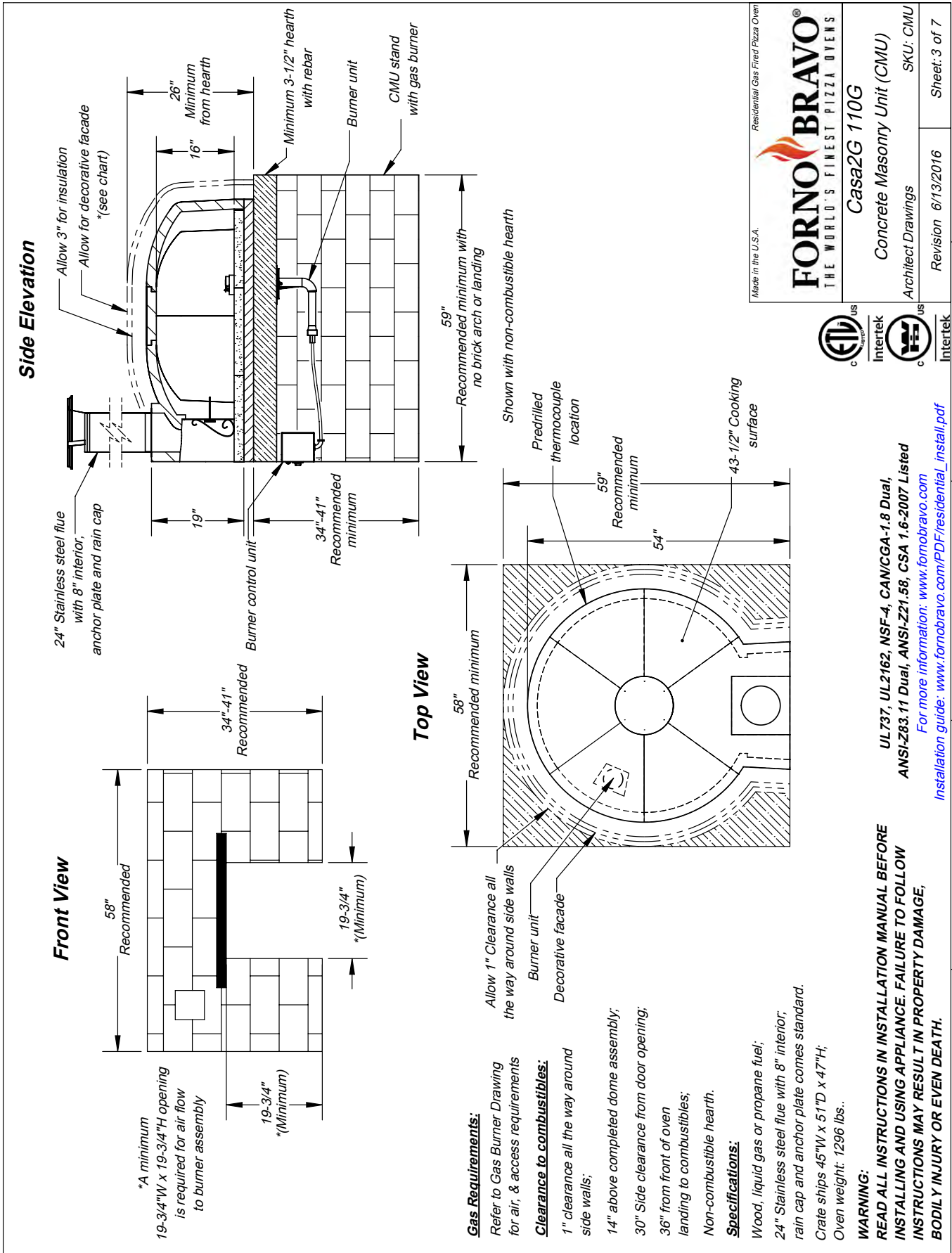

1 2 3 4 5

ISO View

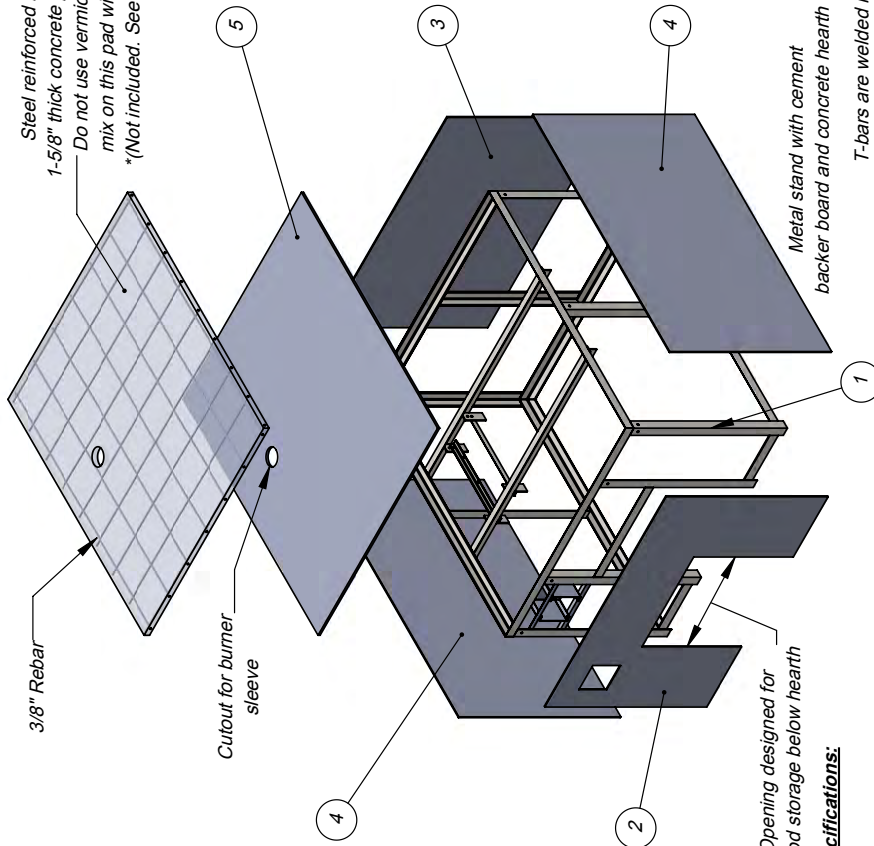

Steel reinforced hearth requires 1-5/8" thick concrete pad with 3/8" rebar. Do not use vermiculite in concrete mix on this pad with Cucina stand. *(Not included. See installation guide)

5

Cutout for burner sleeve

4

3

2

Opening designed for wood storage below hearth
Specifications:
 Stand includes metal frame, assembly hardware, pre-cut / predrilled exterior cement backer board panels.

Metal stand with cement backer board and concrete hearth
 T-bars are welded in for additional strength

DETAIL A
 SCALE 1 : 10

Front View

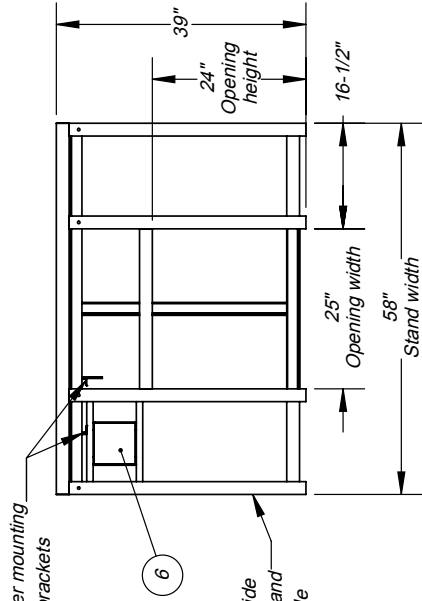

Burner mounting brackets

6

Add 2-1/2" per side for backer board and minimum facade

Side Elevation

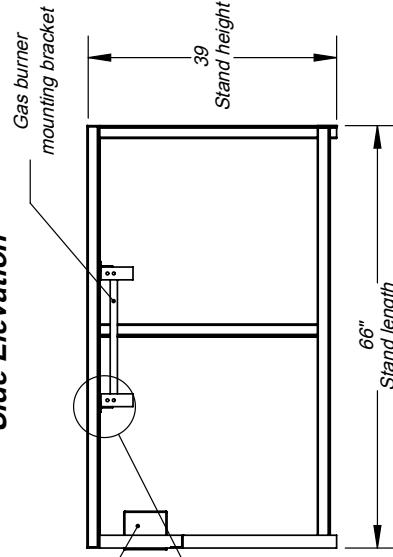

6

Gas burner mounting bracket

6

DETAIL A
 SCALE 1 : 10

The Cucina 110G stand works with Casa2G 110G and Premio2G 100G ovens.

* Hearth materials not included. See installation guide.

WARNING:
 READ ALL INSTRUCTIONS ON INSTALLATION MANUAL BEFORE INSTALLING AND USING APPLIANCE. FAILURE TO FOLLOW INSTRUCTIONS MAY RESULT IN PROPERTY DAMAGE, BODILY INJURY OR EVEN DEATH.

For more information: www.fornobravo.com

Installation guide: www.fornobravo.com/PDF/residential_install.pdf

ITEM#	PART NAME	DESCRIPTION	QTY
1	Cucina2G 110G	Metal frame substructure	1
2	Front Panel	1/4" Pre-cut Backer Board	1
3	Back Panel	1/4" Pre-cut Backer Board	1
4	Side Panel	1/4" Pre-cut Backer Board	2
5	Top Panel	1/2" Pre-cut Backer Board	1
6	Control Box Mount	Secures burner control unit	1
7	Hex Bolt, 3/8" x 1"	*Not displayed	10
8	Hex Nut, 3/8"	*Not displayed	10
9	Self Tapping Screw	*Not displayed	55
	*Concrete Hearth	* See installation guide	
	*Rebar	* See installation guide	



Made in the U.S.A.

Residential Gas Fired Pizza Oven



Cucina 110G

Gas Fired Pizza Oven Stand

Architect Drawings

SKU: ICS110G

Revision 6/13/2016

Sheet: 4 of 7

5 4 3 2 1

ISO View

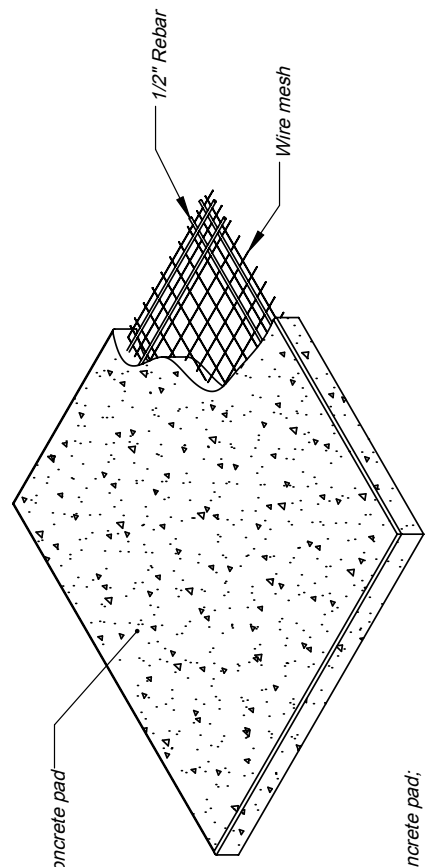

Top View

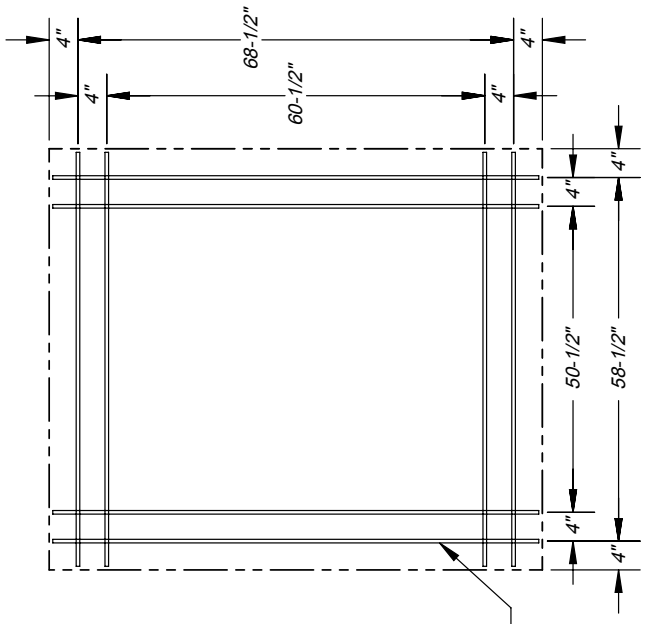

Side Elevation

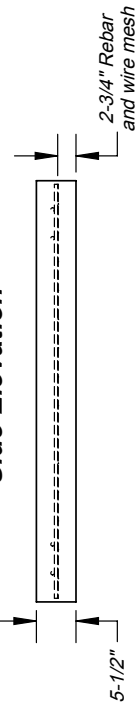

Casa2G 110G oven stand footprint
(*See specifications for CMU stand)

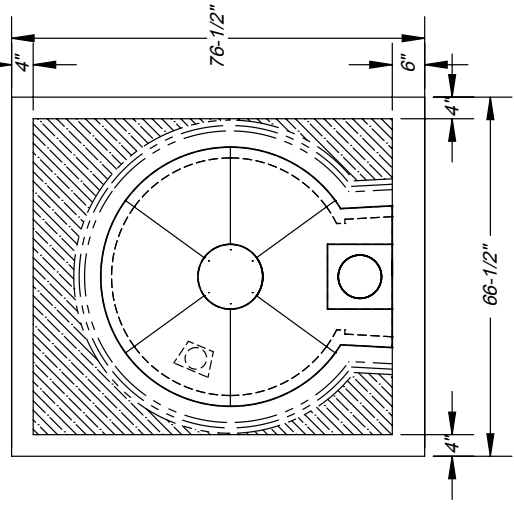

5-1/2" Reinforced concrete pad

1/2" Rebar

Wire mesh

1/2" Rebar

Specifications:

Minimum 5-1/2" deep concrete pad;

Reinforced with 1/2" rebar and wire mesh. * wire mesh is not shown in some views for print clarity;

Cut rebar and wire mesh short to conceal inside concrete pad;

*CMU stand requires a minimum cement foundation pad of 66"W x 69"D

Slab dimensions:

Minimum 8" wider than oven stand and hearth;

Minimum 10" deeper than oven stand and hearth;

Finished slab should be 2" to 3" above ground level;

Refer to local building codes for recommendations regarding soil compaction, frost line and other considerations. Depending on local conditions, you may have to excavate down 18" or more of topsoil to reach stable substrate.

WARNING:
READ ALL INSTRUCTIONS IN INSTALLATION MANUAL BEFORE INSTALLING AND USING APPLIANCE. FAILURE TO FOLLOW INSTRUCTIONS MAY RESULT IN PROPERTY DAMAGE, BODILY INJURY OR EVEN DEATH.

Made in the U.S.A.

Residential Gas Fired Pizza Oven

Casa2G 110G
Gas Fired Pizza Oven Pad
Architect Drawings

Revision 6/13/2016 Sheet: 5 of 7

For more information: www.fornobravo.com
Installation guide: www.fornobravo.com/PDF/residential_install.pdf

Front View

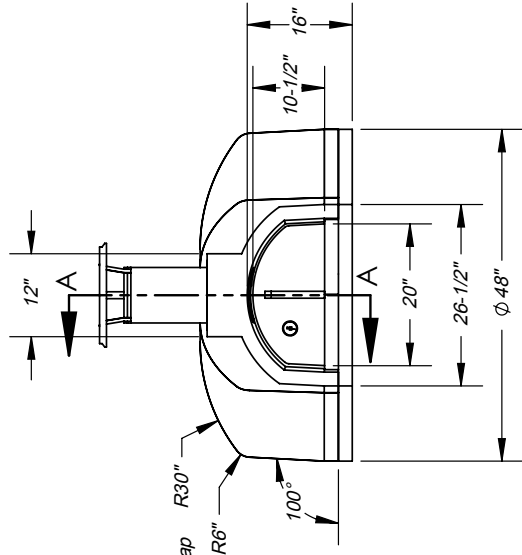

Casa2G 110G Pizza Oven Kit includes:

- Commercial grade refractory oven dome with integral vent
- 2" ceramic fiber insulation board
- 3" ceramic fiber insulation blanket (multiple 1" thick blankets)
- NSF-4 rated fireclay cooking surface
- High temp refractory mortar to seal dome joints
- Single wall stove pipe, anchor plate, 24" pipe and cap
- Single wall steel powder coated door
- Door thermometer

Home Gas Features includes:

- Fuel: Wood, liquid propane or natural gas
- Drago P1 Plus burner assembly (specify, natural gas or liquid propane)
- Burner ignition box with four settings (off, pilot, low and high flame)
- Stainless steel ash guard for burner
- Remote thermometer
- Gas leak detector
- Gas valve regulator

Sold separately:

- UL certified spark arrester
 - Decorative brick arch
 - Double wall insulated steel door to retain heat longer
 - Cucina stand with steel frame and handle-backer board precut
 - Stove pipe extensions
 - Upgrade to double wall chimney for indoor installations / covered patios
 - Pizza Oven Tools, infrared thermometer, gloves and other items
- To be provided by customer / contractor:**
- Concrete support pad with rebar (or equivalent structure)
 - Concrete masonry stand (CMU) or equivalent non-combustible structure
 - Decorative facade materials (stucco, brick, tile, steel, etc.)

Certifications:

Tested and compliant with:
 UL737, UL2162, NSF-4, CAN/CGA-1.8 Dual, ANSI-Z83.11 Dual, ANSI-Z21.58-CSA 1.6-2007
 For more information about our certifications, click here: www.fornobravo.com/ul-certified

WARNING:

**READ ALL INSTRUCTIONS IN INSTALLATION MANUAL BEFORE INSTALLING AND USING APPLIANCE.
 FAILURE TO FOLLOW INSTRUCTIONS MAY RESULT IN PROPERTY DAMAGE, BODILY INJURY OR EVEN DEATH**

Installation manual can be found by clicking on this link: www.fornobravo.com/PDF/residential_install.pdf

Side Elevation

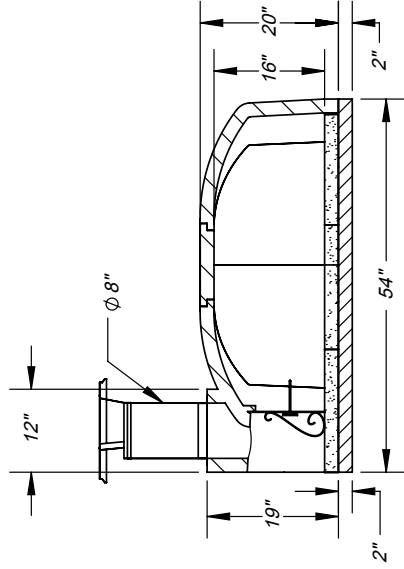

SECTION A-A SCALE 1 : 25

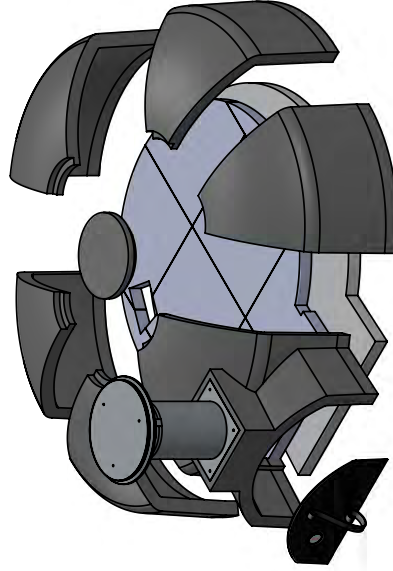

Top View

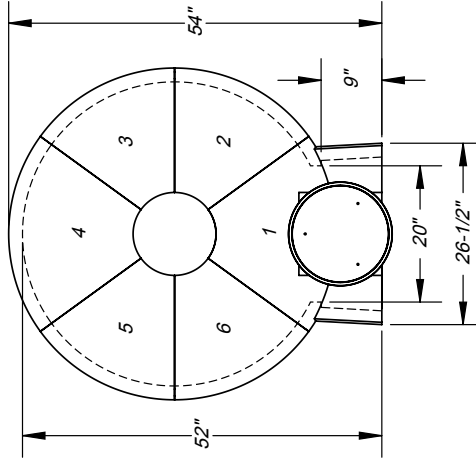

Made in the U.S.A. Residential Gas Fired Pizza Oven

FORNO BRAVO®
 THE WORLD'S FINEST PIZZA OVENS

Casa2G 110G

Gas Fired Pizza Oven

Architect Drawings

Revision 6/13/2016 Sheet: 6 of 7



2 3 4 5 1

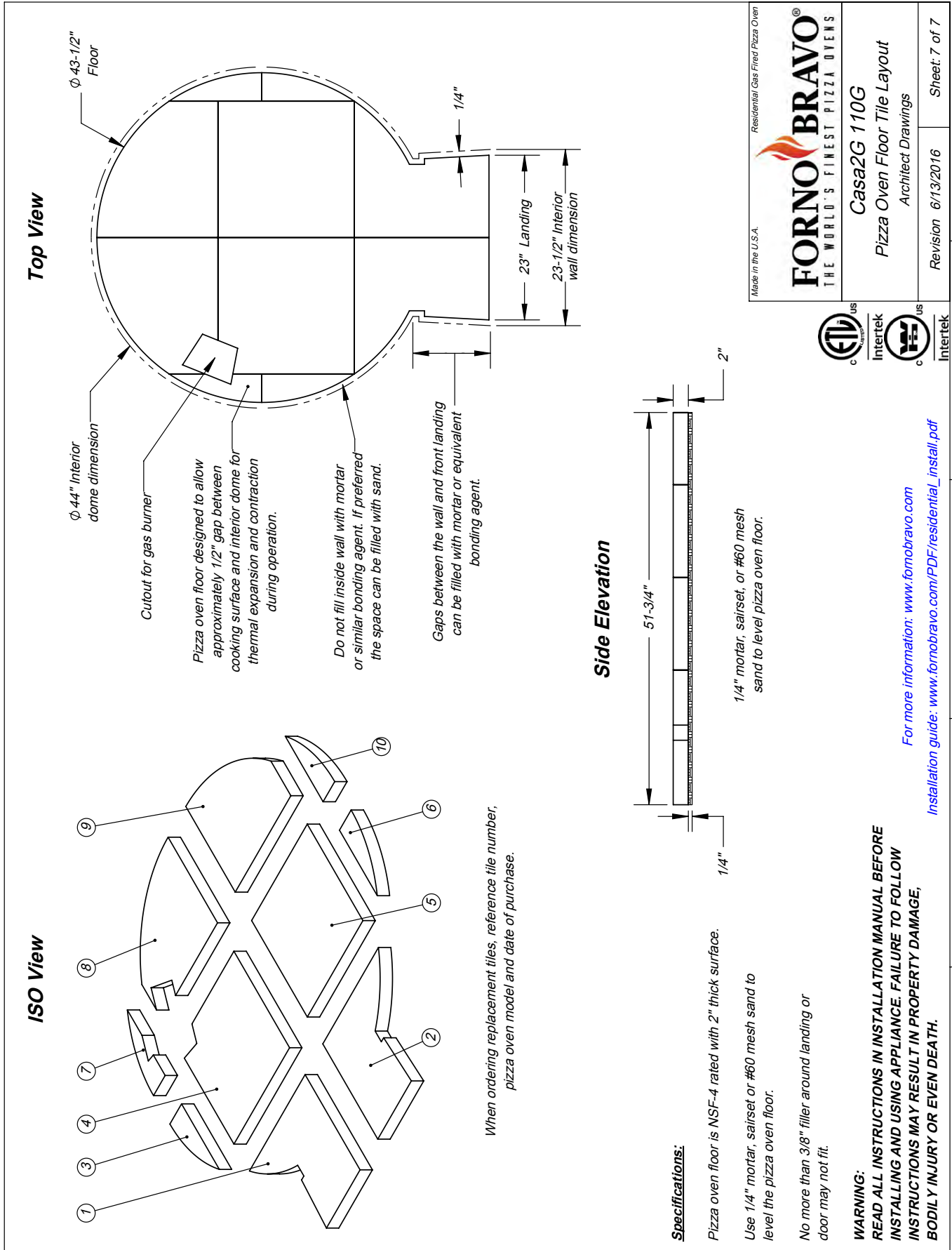

Made in the U.S.A.

FORNO BRAVO
 THE WORLD'S FINEST PIZZA OVENS

Residential Gas Fired Pizza Oven

Casa2G 110G
 Pizza Oven Floor Tile Layout
 Architect Drawings

Revision 6/13/2016 Sheet 7 of 7



1 2 3 4

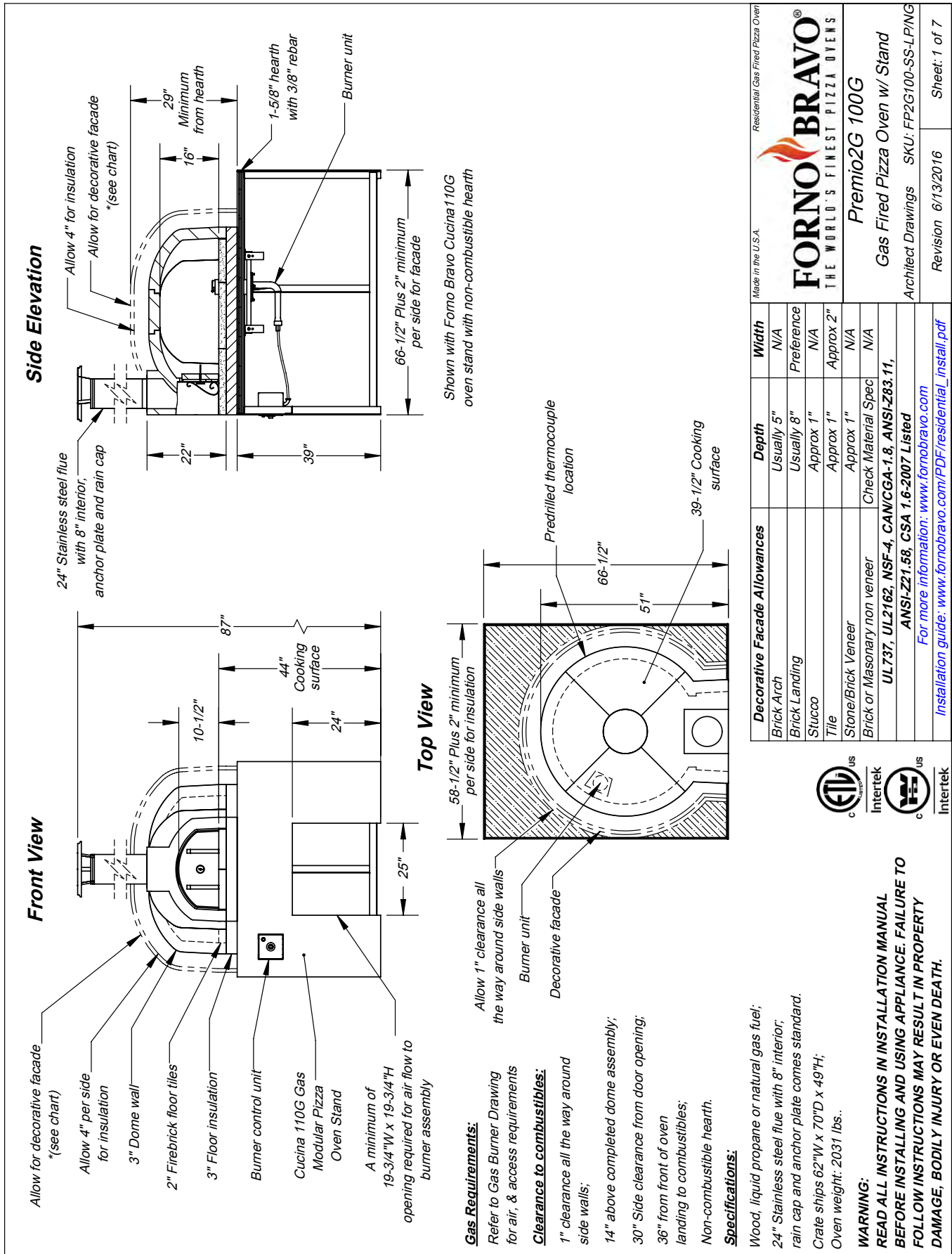

Detailed view of burner placement

SCALE 1:4

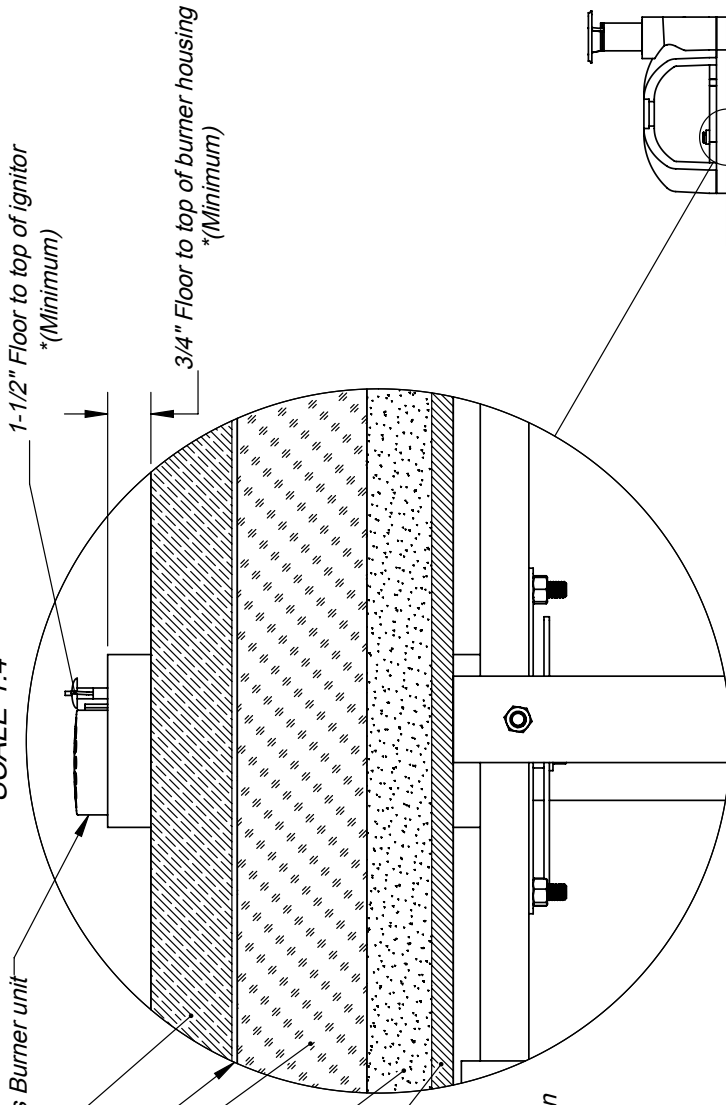

Drago P1 Plus Burner unit

2" Firebrick tiles

1/8" - 3/8" Mortar, sairset, or #60 sand used for leveling floor

3" Ceramic board floor insulation

1-5/8" Concrete hearth with rebar

1/2" Backer board

Specifications:

Cucina stand, concrete CMU stand, or equivalent non-combustible structure's front opening requires a minimum of 19-3/4"W x 19-3/4"H for air flow to burner assembly

Gas line should be 1/2" pipe then reduced to 3/8" union

Liquid Propane line pressure 10 to 12 WC

Natural Gas line pressure 5 to 10 WC

Factory settings:

Natural Gas - 2.75 orifice, air shutter at #2 position

Liquid Propane - 2.25 orifice, air shutter at #3 position

WARNING: DO NOT CHANGE FACTORY SETTINGS WITHOUT CONSULTING MANUFACTURER OR CERTIFIED TECHNICIAN.

WARNING: READ ALL INSTRUCTIONS IN INSTALLATION MANUAL BEFORE INSTALLING AND USING APPLIANCE. FAILURE TO FOLLOW INSTRUCTIONS MAY RESULT IN PROPERTY DAMAGE, BODILY INJURY OR EVEN DEATH.

UL approved settings for gas orifices		NG	LP
Input rate w/ 2.5 orifice and air shutter at #2 setting (Btu/hr)		32000	
Input rate w/ 2.7 orifice and air shutter at #2 setting (Btu/hr)		38000	
Input rate w/ 1.75 orifice and air shutter at #3 setting (Btu/hr)			32000
Input rate w/ 2.0 orifice and air shutter at #3 setting (Btu/hr)			43000
Input rate w/ 2.25 orifice and air shutter at #3 setting (Btu/hr)			51000
Input rate w/ 2.5 orifice and air shutter at #4 setting (Btu/hr)			46000

For more information: www.fornobravo.com

Installation guide: www.fornobravo.com/PDF/residential_install.pdf

Forno Bravo Premio2G 100G Pizza Oven and Cucina 110G Modular Pizza Oven Stand

Made in the U.S.A.

Residential Gas Fired Pizza Oven



Premio2G 100G

Gas Burner Detailed View

Architect Drawings

Revision 6/13/2016 Sheet: 2 of 7



Intertek



Intertek

Front View

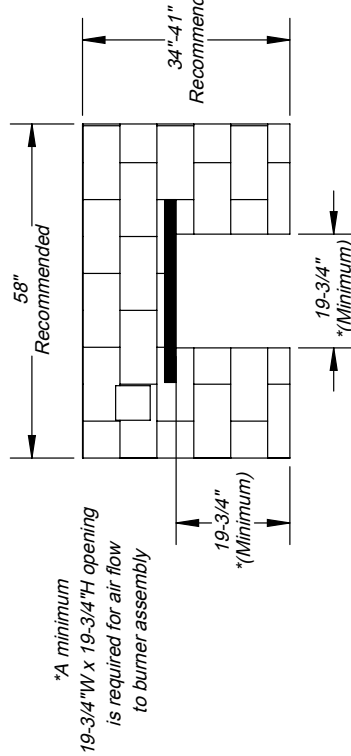

Side Elevation

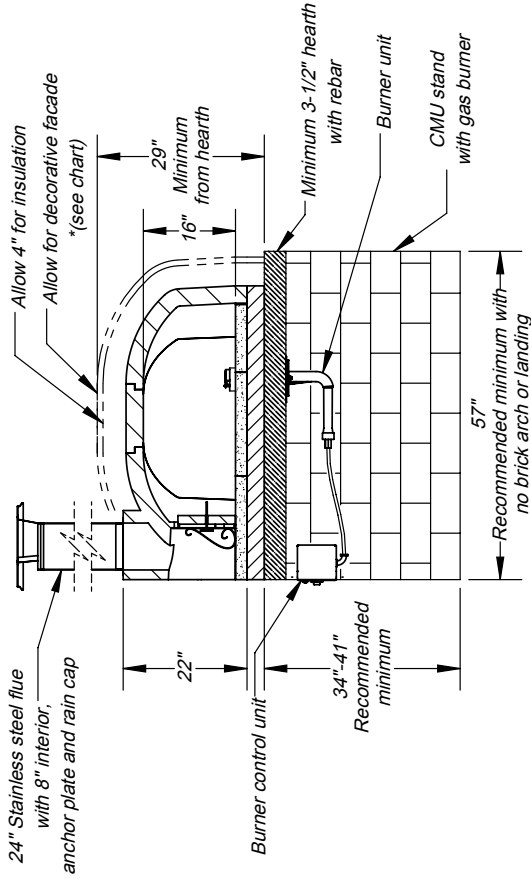

Top View

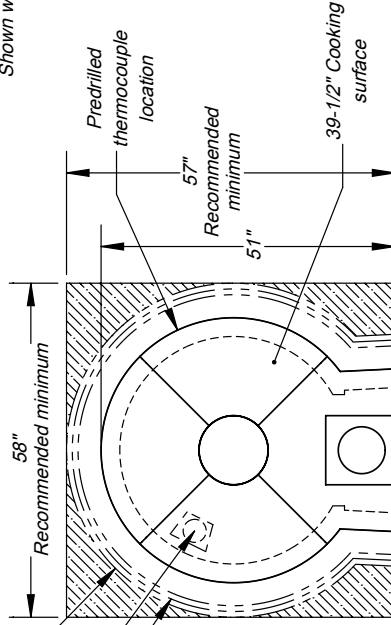

Gas Requirements:

Refer to Gas Burner Drawing for air, & access requirements

Clearance to combustibles:

- 1" clearance all the way around side walls;
- 14" above completed dome assembly;
- 30" Side clearance from door opening;
- 36" from front of oven landing to combustibles;
- Non-combustible hearth.

Specifications:

- Wood, liquid propane or natural gas fuel;
- 24" Stainless steel flue with 8" interior; rain cap and anchor plate comes standard.
- Crate ships 48"W x 54"D x 49"H;
- Oven weight: 1350 lbs..

WARNING:

READ ALL INSTRUCTIONS IN INSTALLATION MANUAL BEFORE INSTALLING AND USING APPLIANCE. FAILURE TO FOLLOW INSTRUCTIONS MAY RESULT IN PROPERTY DAMAGE, BODILY INJURY OR EVEN DEATH.

Shown with non-combustible hearth

Made in the U.S.A. Residential Gas Fired Pizza Oven

FORNO BRAVO®
THE WORLD'S FINEST PIZZA OVENS

Premio2G 100G

Concrete Masonry Unit (CMU)

Architect Drawings SKU: CMU

Revision 6/13/2016 Sheet: 3 of 7



UL737, UL2162, NSF-4, CAN/CGA-1.8 Dual, ANSI-Z83.11 Dual, ANSI-Z21.58, CSA 1.6-2007 Listed

For more information: www.fornobravo.com

Installation guide: www.fornobravo.com/PDF/residential_install.pdf

ISO View

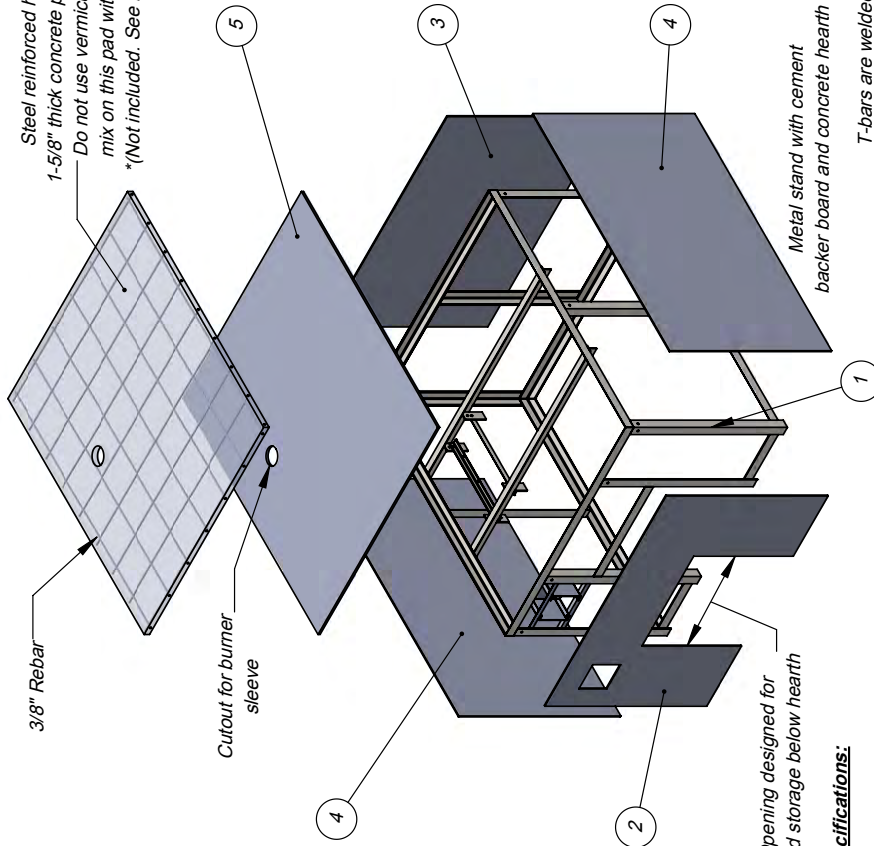

Opening designed for wood storage below hearth

Specifications:
Stand includes metal frame, assembly hardware, pre-cut / pre-filled exterior cement backer board panels.

The Cucina 110G stand works with Premio2G 100G and Casa2G 110G ovens.

* Hearth materials not included. See installation guide.

WARNING:
READ ALL INSTRUCTIONS IN INSTALLATION MANUAL BEFORE INSTALLING AND USING APPLIANCE. FAILURE TO FOLLOW INSTRUCTIONS MAY RESULT IN PROPERTY DAMAGE, BODILY INJURY OR EVEN DEATH.

For more information: www.fornobravo.com
Installation guide: www.fornobravo.com/PDF/residential_install.pdf



Front View

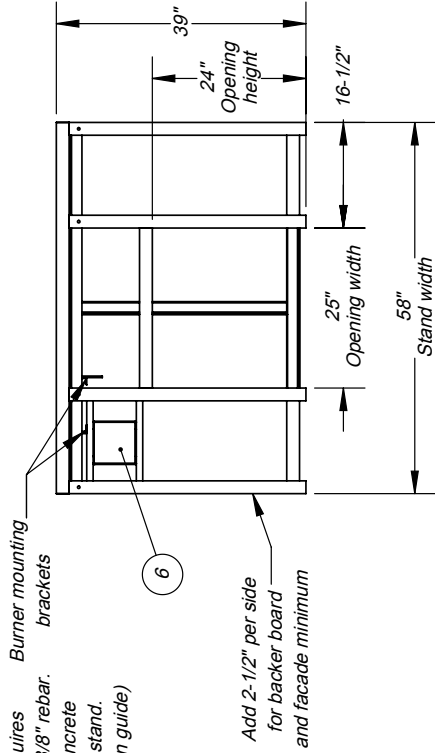

Side Elevation

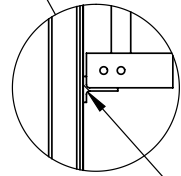
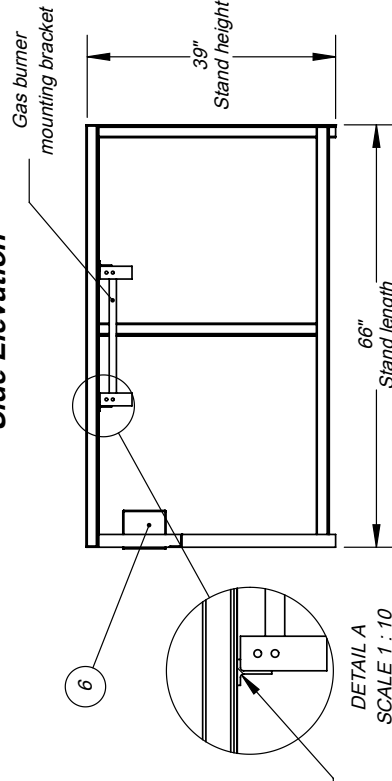

DETAIL A
SCALE 1 : 10

ITEM#	PART NAME	DESCRIPTION	QTY
1	Cucina2G 110G	Metal frame substructure	1
2	Front Panel	1/4\" Pre-cut Backer Board	1
3	Back Panel	1/4\" Pre-cut Backer Board	1
4	Side Panel	1/4\" Pre-cut Backer Board	2
5	Top Panel	1/2\" Pre-cut Backer Board	1
6	Control Box Mount	Secures burner control unit	1
7	Hex Bolt, 3/8\" x 1\"	*Not displayed	10
8	Hex Nut, 3/8\"	*Not displayed	10
9	Self Tapping Screw	*Not displayed	55
	Concrete Hearth	* See installation guide	
	*Rebar	* See installation guide	



Cucina 110G
Gas Fired Pizza Oven Stand
Architect Drawings
Revision 6/13/2016
SKU: ICS110G
Sheet: 4 of 7

ISO View

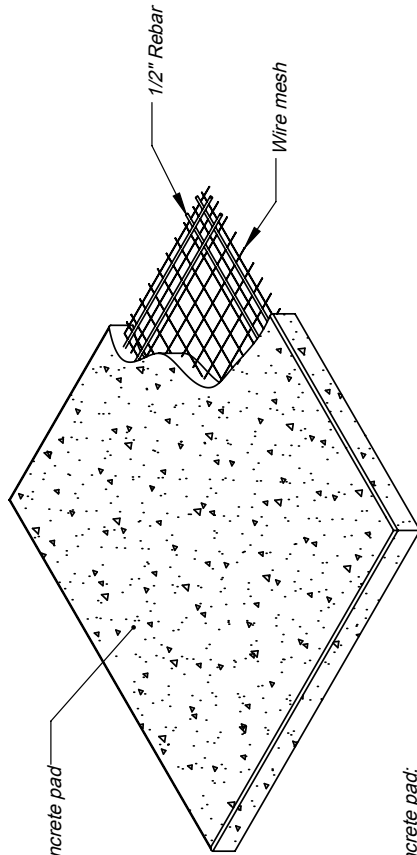

Top View

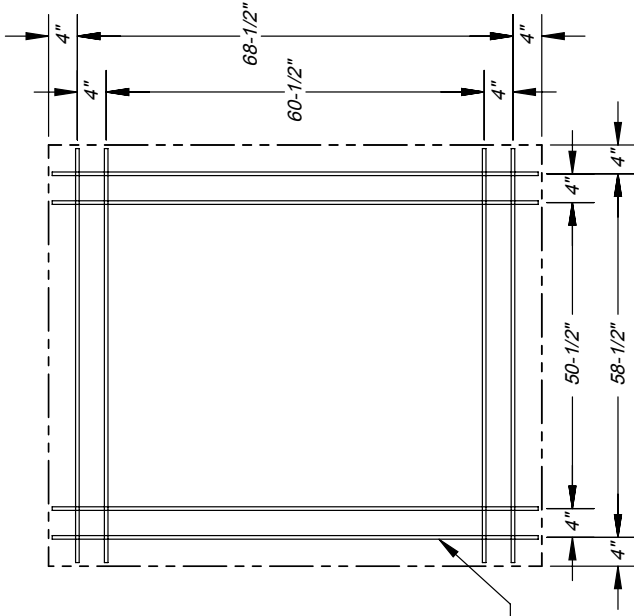

Side Elevation

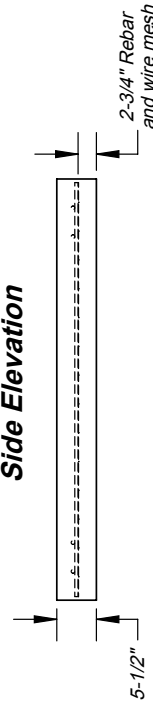

Premio2G 100G oven stand footprint
(*See specifications for CMU stand)

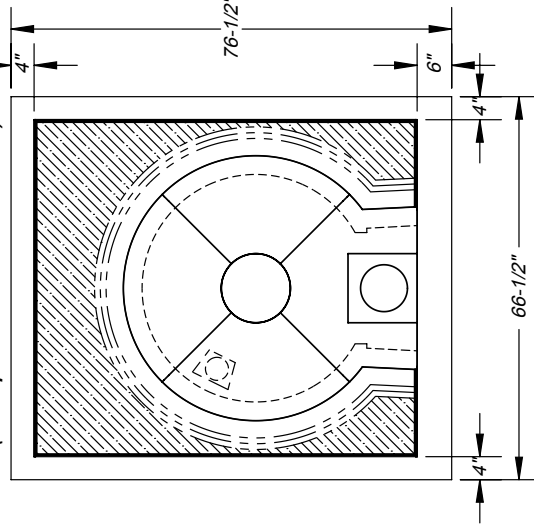

Specifications:

- Minimum 5-1/2" deep concrete pad;
- Reinforced with 1/2" rebar and wire mesh. * wire mesh is not shown in some views for print clarity;
- Cut rebar and wire mesh short to conceal inside concrete pad;
- *CMU stand requires a minimum cement foundation pad of 58"W x 57"D

Slab dimensions:

- Minimum 8" wider than oven stand and hearth;
- Minimum 10" deeper than oven stand and hearth;
- Finished slab should be 2" to 3" above ground level;

Refer to local building codes for recommendations regarding soil compaction, frost line and other considerations. Depending on local conditions, you may have to excavate down 18" or more of topsoil to reach stable substrate.

WARNING:

READ ALL INSTRUCTIONS IN INSTALLATION MANUAL BEFORE INSTALLING AND USING APPLIANCE. FAILURE TO FOLLOW INSTRUCTIONS MAY RESULT IN PROPERTY DAMAGE, BODILY INJURY OR EVEN DEATH.

For more information: www.fornobravo.com
Installation guide: www.fornobravo.com/PDF/residential_install.pdf

Made in the U.S.A. Residential Gas Fired Pizza Oven

FORNO BRAVO®
THE WORLD'S FINEST PIZZA OVENS

Premio2G 100G
Gas Fired Pizza Oven Pad
Architect Drawings

Revision 6/13/2016 Sheet: 5 of 7



Front View

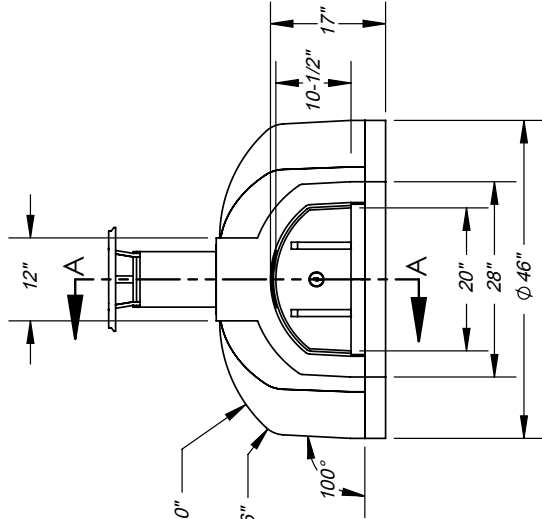

Premio2G 100G Pizza Oven Kit includes:

- Commercial grade refractory oven dome with integral vent
- 3" ceramic fiber insulation board
- 4" ceramic fiber insulation blanket (multiple 1" thick blankets)
- NSF-4 rated fireclay cooking surface
- High temp refractory mortar to seal dome joints
- Single wall stove pipe, anchor plate, 24" pipe and cap
- Double wall insulated steel door
- Door thermometer

Home Gas Features includes:

- Fuel: Wood, liquid propane or natural gas
- Drago P1 Plus burner assembly (specify, natural gas or liquid propane)
- Burner ignition box with four settings (off, pilot, low and high flame)
- Stainless steel ash guard for burner
- Remote thermometer
- Gas leak detector
- Propane Gas valve regulator. *(Note: Natural gas regulator must be supplied by local certified installer.)

Sold separately:

- UL certified spark arrestor
- Decorative brick arch
- Double wall insulated steel door to retain heat longer
- Cucina stand with steel frame and hardie-backer board pre-cut
- Stove pipe extension
- Upgrade to double wall chimney for indoor installations / covered patios
- Pizza Oven Tools, infrared thermometer, gloves and other items

To be provided by customer / contractor:

- Concrete support pad with rebar (or equivalent structure)
- Concrete masonry stand (CMU) or equivalent non-combustible structure
- Decorative facade materials (stucco, brick, tile, steel, etc.)

Certifications:

Tested and compliant with:
 UL737, UL2162, NSF-4, CAN/CGA-1.8 Dual, ANSI-Z83.11 Dual, ANSI-Z21.58-CSA 1.6-2007
 For more information about our certifications, click here: www.fornobravo.com/ul-certified

WARNING:

READ ALL INSTRUCTIONS IN INSTALLATION MANUAL BEFORE INSTALLING AND USING APPLIANCE. FAILURE TO FOLLOW INSTRUCTIONS MAY RESULT IN PROPERTY DAMAGE, BODILY INJURY OR EVEN DEATH
 Installation manual can be found by clicking on this link: www.fornobravo.com/PDF/residential_install.pdf

Side Elevation

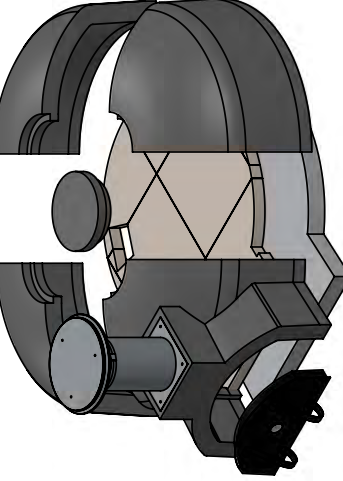
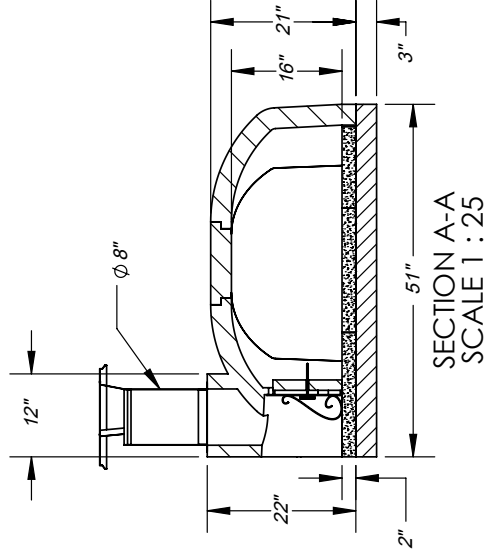

Top View

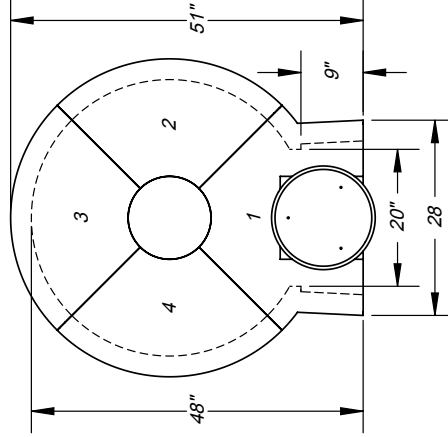

Made in the U.S.A. Residential Gas Fired Pizza Oven

FORNO BRAVO®
 THE WORLD'S FINEST PIZZA OVENS

Premio2G 100G
 Gas Fired Pizza Oven
 Architect Drawings

Revision 6/13/2016 Sheet: 6 of 7



1 2 3 4 5

ISO View

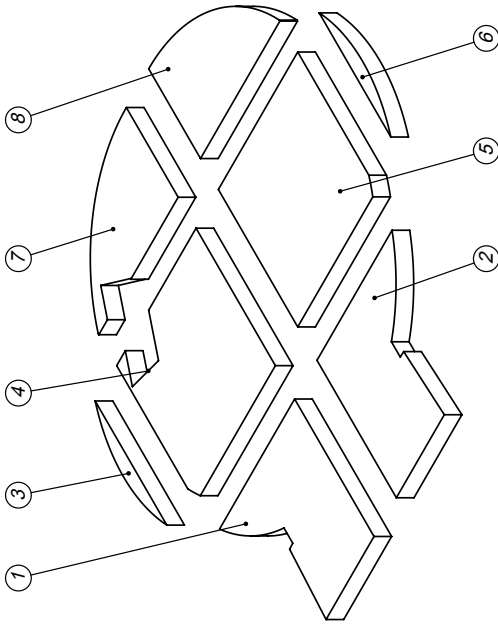

When ordering replacement tiles, reference tile number, pizza oven model and date of purchase.

Top View

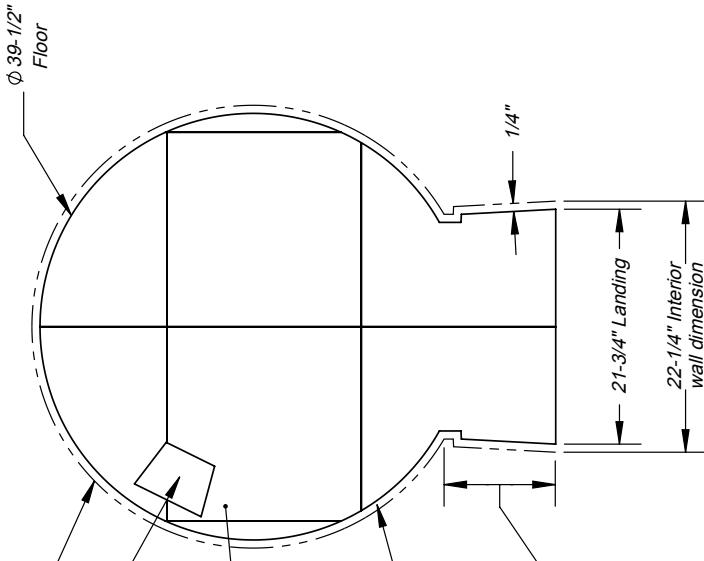

Side Elevation

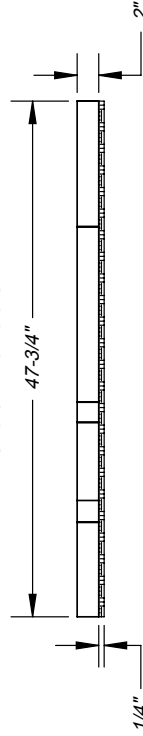

1/4" mortar, sairset, or #60 mesh sand to level pizza oven floor.

Specifications:

Pizza oven floor is NSF-4 rated with 2" thick surface.
 Use 1/4" mortar, sairset, or #60 mesh sand to level the pizza oven floor.
 No more than 3/8" filler around landing or door may not fit.

WARNING:
READ ALL INSTRUCTIONS IN INSTALLATION MANUAL BEFORE INSTALLING AND USING APPLIANCE. FAILURE TO FOLLOW INSTRUCTIONS MAY RESULT IN PROPERTY DAMAGE, BODILY INJURY OR EVEN DEATH.

For more information: www.fornobravo.com
 Installation guide: www.fornobravo.com/PDF/residential_install.pdf

Made in the U.S.A. Residential Gas Fired Pizza Oven



Premio2G 100G

Pizza Oven Floor Tile Layout
Architect Drawings

Revision 6/13/2016 Sheet: 7 of 7



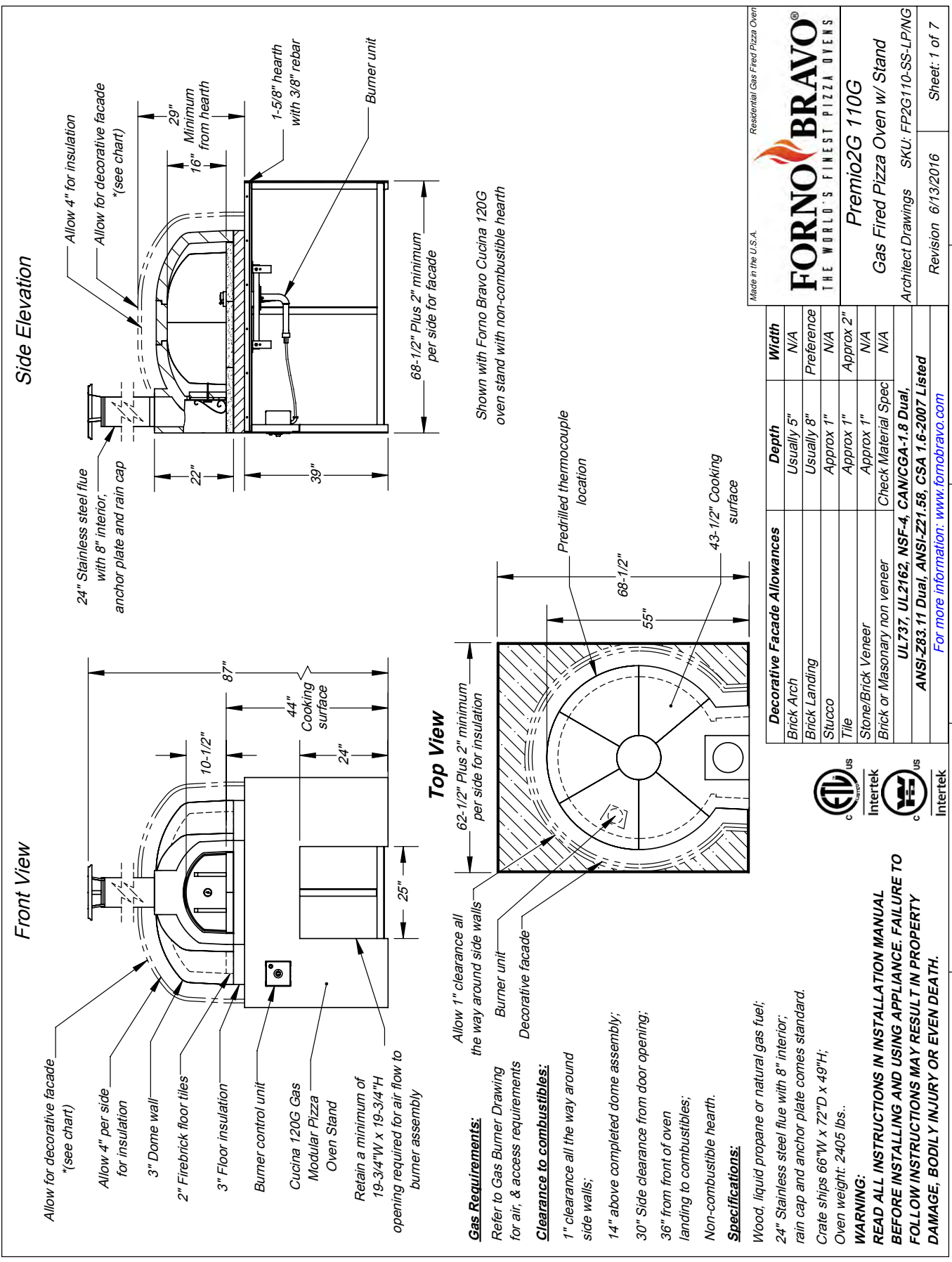

Side Elevation

Front View

Top View

Shown with Forno Bravo Cucina 120G oven stand with non-combustible hearth

- Allow for decorative facade *(see chart)
- Allow 4" per side for insulation
- 3" Dome wall
- 2" Firebrick floor tiles
- 3" Floor insulation
- Burner control unit
- Cucina 120G Gas Modular Pizza Oven Stand
- Retain a minimum of 19-3/4"W x 19-3/4"H opening required for air flow to burner assembly

Gas Requirements:
Refer to Gas Burner Drawing for air, & access requirements

Clearance to combustibles:
1" clearance all the way around side walls;
14" above completed dome assembly;
30" Side clearance from door opening;
36" from front of oven landing to combustibles;
Non-combustible hearth.

Specifications:
Wood, liquid propane or natural gas fuel;
24" Stainless steel flue with 8" interior;
rain cap and anchor plate comes standard.
Crate ships 66"W x 72"D x 49"H;
Oven weight: 2405 lbs..

WARNING:
READ ALL INSTRUCTIONS IN INSTALLATION MANUAL BEFORE INSTALLING AND USING APPLIANCE. FAILURE TO FOLLOW INSTRUCTIONS MAY RESULT IN PROPERTY DAMAGE, BODILY INJURY OR EVEN DEATH.

Made in the U.S.A. Residential Gas Fired Pizza Oven

FORNO BRAVO®
THE WORLD'S FINEST PIZZA OVENS

Premio2G 110G
Gas Fired Pizza Oven w/ Stand
Architect Drawings SKU: FP2G110-SS-LP/NG
Revision 6/13/2016 Sheet: 1 of 7

Decorative Facade Allowances	Depth	Width
Brick Arch	Usually 5"	N/A
Brick Landing	Usually 8"	Preference
Stucco	Approx 1"	N/A
Tile	Approx 1"	Approx 2"
Stone/Brick Veneer	Approx 1"	N/A
Brick or Masonry non veneer	Check Material Spec	N/A
UL737, UL2162, NSF-4, CAN/CGA-1.8 Dual, ANSI-Z83.11 Dual, ANSI-Z21.58, CSA 1.6-2007 Listed		
For more information: www.fornobravo.com		



Detailed view of burner placement
SCALE 1:4

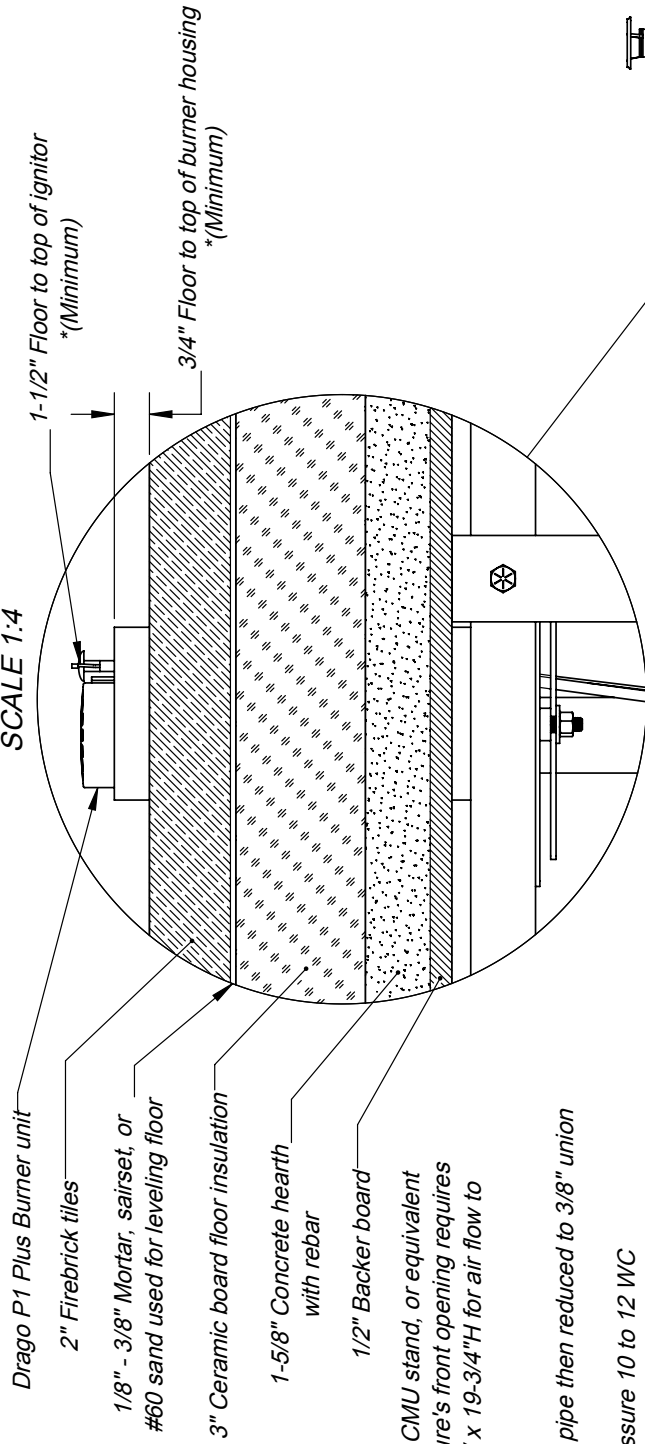

- Drago P1 Plus Burner unit
- 2" Firebrick tiles
- 1/8" - 3/8" Mortar, satsset, or #60 sand used for leveling floor
- 3" Ceramic board floor insulation
- 1-5/8" Concrete hearth with rebar
- 1/2" Backer board

Specifications:

Cucina stand, concrete CMU stand, or equivalent non-combustible structure's front opening requires a minimum of 19-3/4"W x 19-3/4"H for air flow to burner assembly

Gas line should be 1/2" pipe then reduced to 3/8" union

Liquid Propane line pressure 10 to 12 WC

Natural Gas line pressure 5 to 10 WC

Factory settings:

Natural Gas - 2.75 orifice, air shutter at #2 position

Liquid Propane - 2.25 orifice, air shutter at #3 position

WARNING: DO NOT CHANGE FACTORY SETTINGS WITHOUT CONSULTING MANUFACTURER OR CERTIFIED TECHNICIAN.

WARNING: READ ALL INSTRUCTIONS IN INSTALLATION MANUAL BEFORE INSTALLING AND USING APPLIANCE. FAILURE TO FOLLOW INSTRUCTIONS MAY RESULT IN PROPERTY DAMAGE, BODILY INJURY OR EVEN DEATH.

UL approved settings for gas orifices	
NG	LP
Input rate w/ 2.5 orifice and air shutter at #2 setting (Btu/hr)	32000
Input rate w/ 2.7 orifice and air shutter at #2 setting (Btu/hr)	38000
Input rate w/ 1.75 orifice and air shutter at #3 setting (Btu/hr)	32000
Input rate w/ 2.0 orifice and air shutter at #3 setting (Btu/hr)	43000
Input rate w/ 2.25 orifice and air shutter at #3 setting (Btu/hr)	51000
Input rate w/ 2.5 orifice and air shutter at #4 setting (Btu/hr)	46000

For more information: www.fornobravo.com

Installation guide: www.fornobravo.com/PDF/residential_install.pdf

Forno Bravo Premio2G 110G Pizza Oven
and Cucina 110G Modular Pizza Oven Stand

Made in the U.S.A.

Residential Gas Fired Pizza Oven



FORNO BRAVO
THE WORLD'S FINEST PIZZA OVENS

Premio2G 110G

Gas Burner Detailed View

Architect Drawings

Revision 6/13/2016

Sheet: 2 of 7

Front View

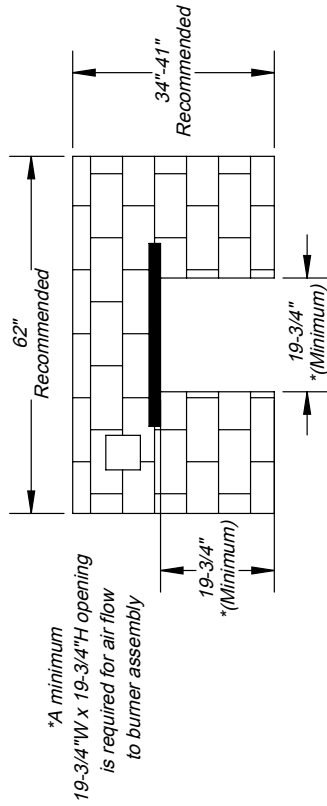

Side Elevation

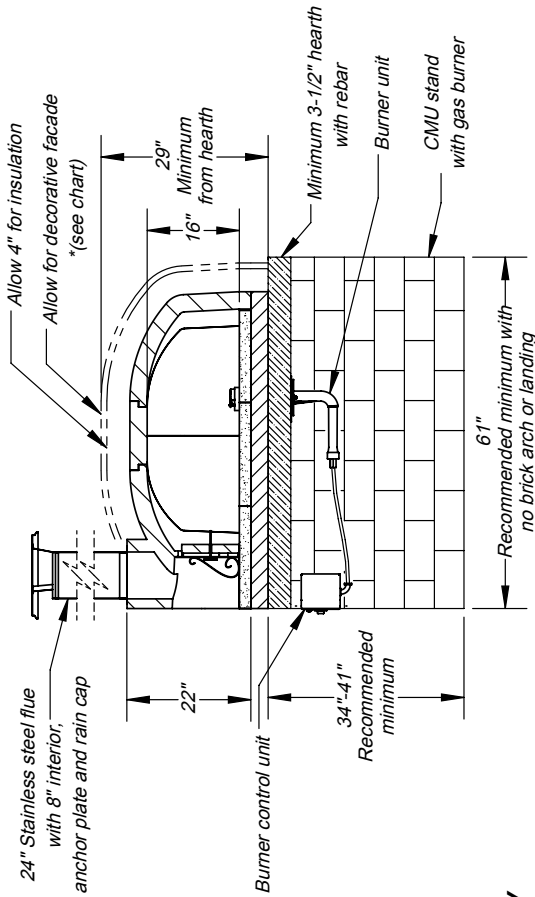

Top View

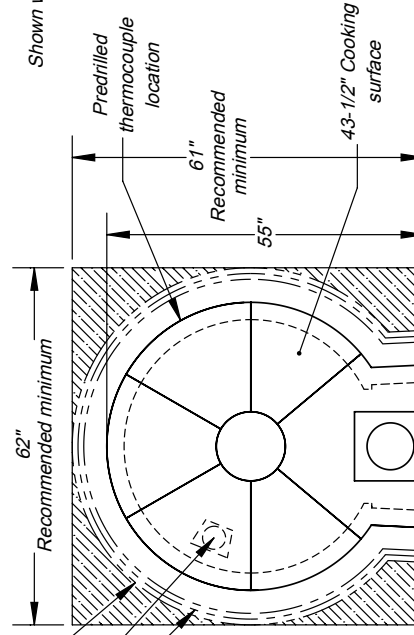

Gas Requirements:

Refer to Gas Burner Drawing for air, & access requirements

Clearance to combustibles:

1" clearance all the way around side walls;

14" above completed dome assembly;

30" Side clearance from door opening;

36" from front of oven landing to combustibles;

Non-combustible hearth.

Specifications:

Wood, liquid gas or propane fuel;

24" Stainless steel flue with 8" interior; rain cap and anchor plate comes standard.

Crate ships 49"W x 55"D x 49"H;

Oven weight: 1620 lbs..

WARNING:

READ ALL INSTRUCTIONS IN INSTALLATION MANUAL BEFORE INSTALLING AND USING APPLIANCE. FAILURE TO FOLLOW INSTRUCTIONS MAY RESULT IN PROPERTY DAMAGE, BODILY INJURY OR EVEN DEATH.

Shown with non-combustible hearth

Allow 1" clearance all the way around side walls

Burner unit

Decorative facade

62" Recommended minimum

Predrilled thermocouple location

61" Recommended minimum

43-1/2" Cooking surface

22"

34"-41" Recommended minimum

61"

Recommended minimum with no brick arch or landing

29" Minimum from hearth

16"

Minimum 3-1/2" hearth with rebar

Burner unit

CMU stand with gas burner

Allow 4" for insulation

Allow for decorative facade *(see chart)

Made in the U.S.A.

Residential Gas Fired Pizza Oven

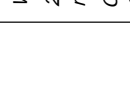
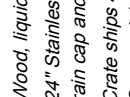
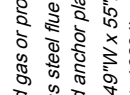
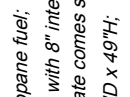
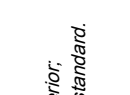
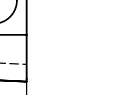
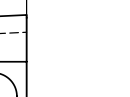
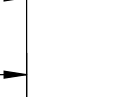

FORNO BRAVO®
THE WORLD'S FINEST PIZZA OVENS

Premio2G 110G

Concrete Masonry Unit (CMU)

Architect Drawings

Revision 6/13/2016

SKU: CMU

Sheet: 3 of 7

UL737, UL2162, NSF-4, CAN/CGA-1.8 Dual, ANSI-Z83.11 Dual, ANSI-Z21.58, CSA 1.6-2007 Listed
For more information: www.fornobravo.com
Installation guide: www.fornobravo.com/PDF/residential_install.pdf

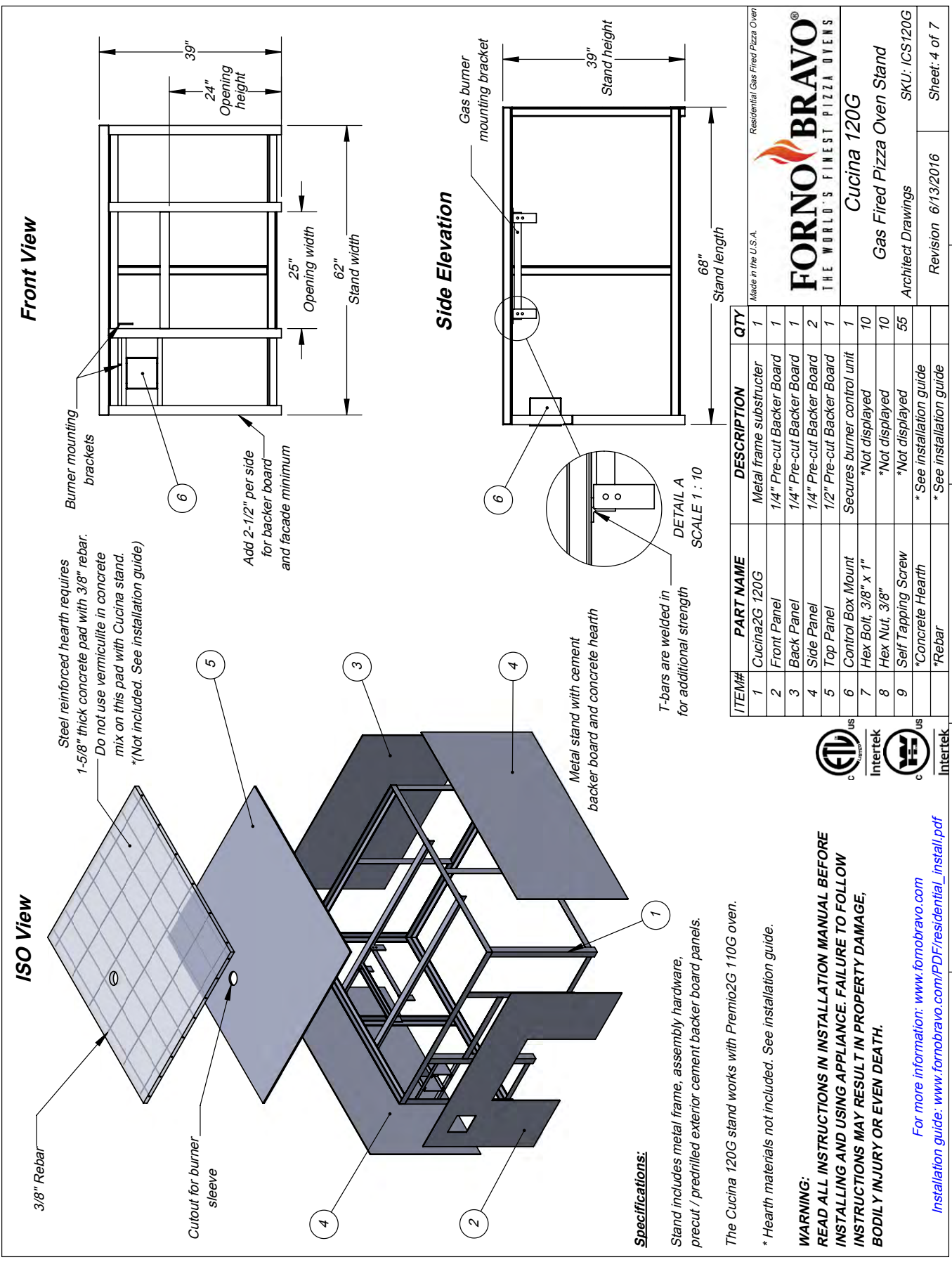

Front View

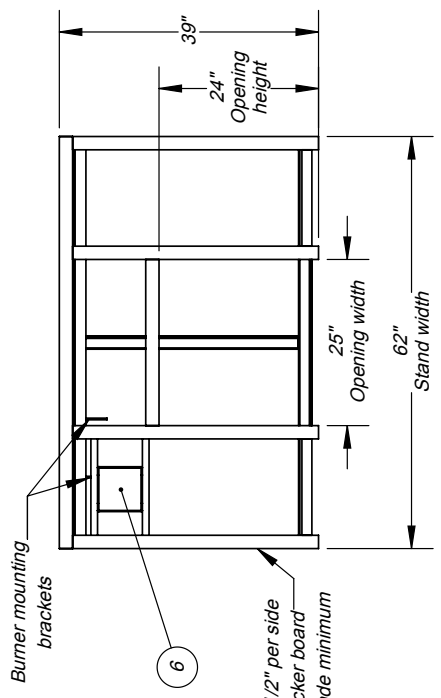

Side Elevation

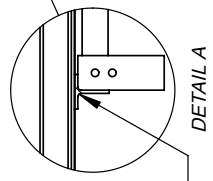
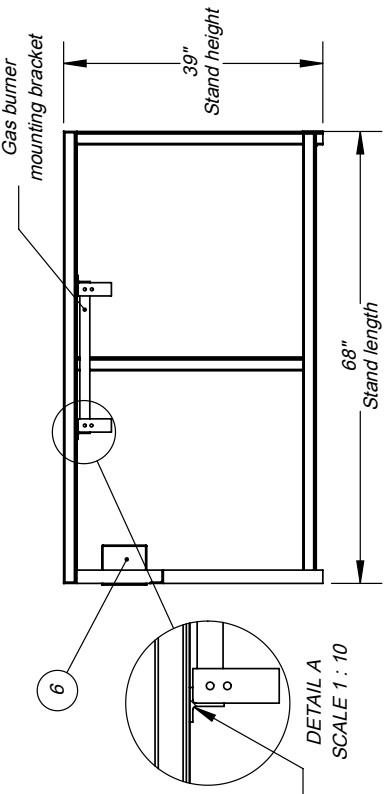

ITEM#	PART NAME	DESCRIPTION	QTY
1	Cucina2G 120G	Metal frame substructure	1
2	Front Panel	1/4\" Pre-cut Backer Board	1
3	Back Panel	1/4\" Pre-cut Backer Board	1
4	Side Panel	1/4\" Pre-cut Backer Board	2
5	Top Panel	1/2\" Pre-cut Backer Board	1
6	Control Box Mount	Secures burner control unit	1
7	Hex Bolt, 3/8\" x 1\"	*Not displayed	10
8	Hex Nut, 3/8\"	*Not displayed	10
9	Self Tapping Screw	*Not displayed	55
	*Concrete Hearth	* See installation guide	
	*Rebar	* See installation guide	

Made in the U.S.A.
Residential Gas Fired Pizza Oven

FORNO BRAVO®
THE WORLD'S FINEST PIZZA OVENS

Cucina 120G
Gas Fired Pizza Oven Stand

Architect Drawings
Revision 6/13/2016
SKU: ICS120G
Sheet: 4 of 7

ISO View

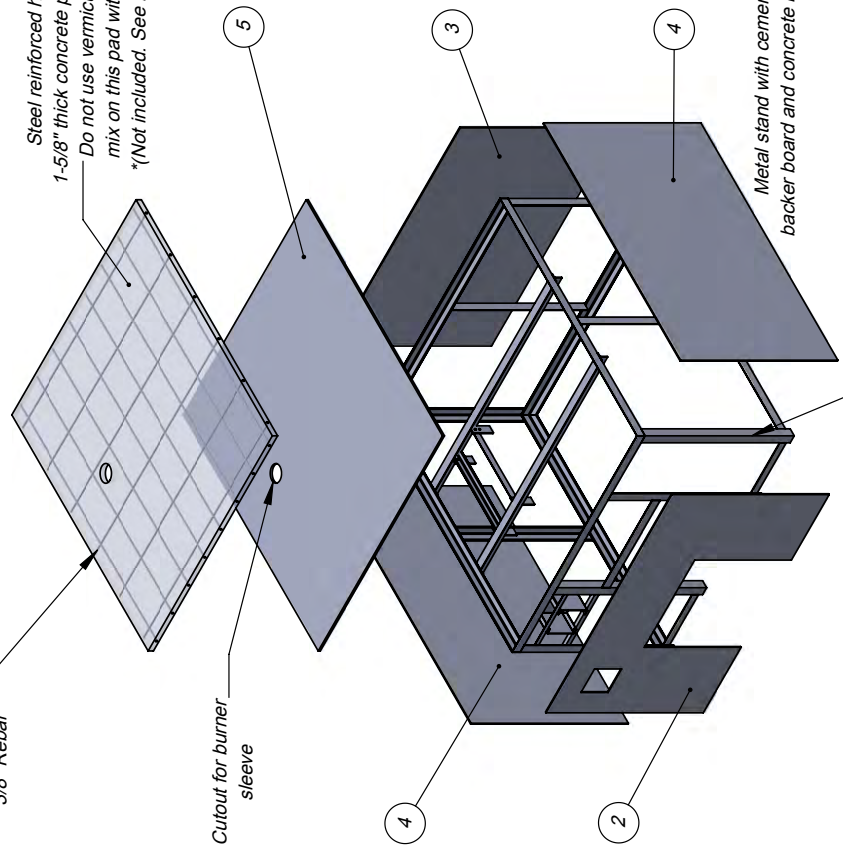

Specifications:

Stand includes metal frame, assembly hardware, precut / predrilled exterior cement backer board panels.

The Cucina 120G stand works with Premio2G 110G oven.

* Hearth materials not included. See installation guide.

WARNING:
READ ALL INSTRUCTIONS IN INSTALLATION MANUAL BEFORE INSTALLING AND USING APPLIANCE. FAILURE TO FOLLOW INSTRUCTIONS MAY RESULT IN PROPERTY DAMAGE, BODILY INJURY OR EVEN DEATH.

For more information: www.fornobravo.com
Installation guide: www.fornobravo.com/PDF/residential_install.pdf



ISO View

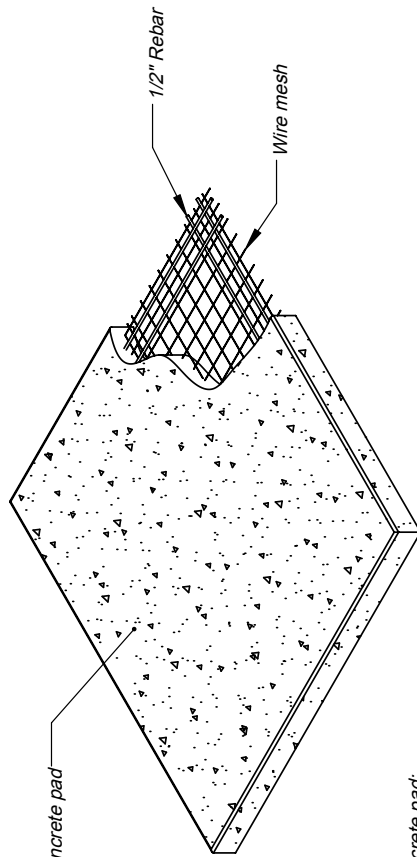

Top View

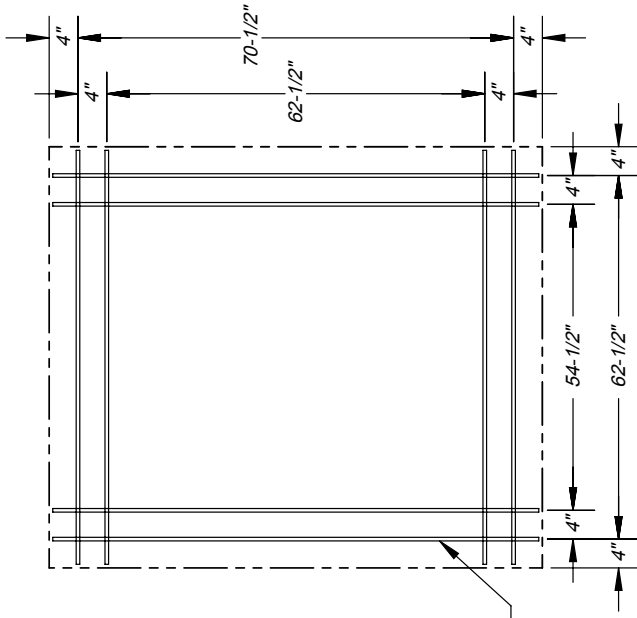

Side Elevation

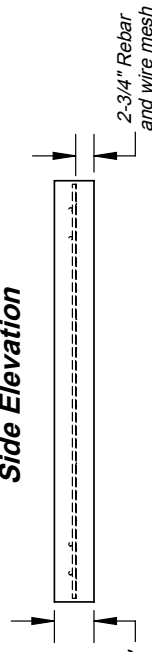

Premio2G 110G oven stand footprint
(*See specifications for CMU stand)

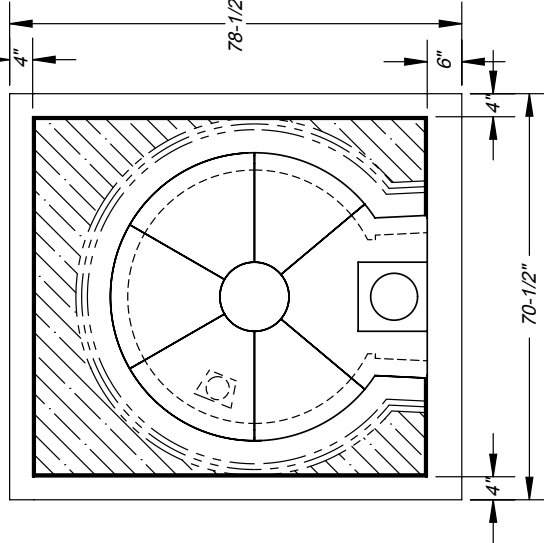

Specifications:

Minimum 5-1/2" deep concrete pad;

Reinforced with 1/2" rebar and wire mesh. * wire mesh is not shown in some views for print clarity;

Cut rebar and wire mesh short to conceal inside concrete pad;

*CMU stand requires a minimum cement foundation pad of 70"W x 71"D

Slab dimensions:

Minimum 8" wider than oven stand and hearth;

Minimum 10" deeper than oven stand and hearth;

Finished slab should be 2" to 3" above ground level;

Refer to local building codes for recommendations regarding soil compaction, frost line and other considerations. Depending on local conditions, you may have to excavate down 18" or more of topsoil to reach stable substrate.

WARNING:

READ ALL INSTRUCTIONS IN INSTALLATION MANUAL BEFORE INSTALLING AND USING APPLIANCE. FAILURE TO FOLLOW INSTRUCTIONS MAY RESULT IN PROPERTY DAMAGE, BODILY INJURY OR EVEN DEATH.

Made in the U.S.A.

Residential Gas Fired Pizza Oven

Premio2G 110G
Gas Fired Pizza Oven Pad
Architect Drawings

Revision 6/13/2016 Sheet: 5 of 7



For more information: www.fornobravo.com
Installation guide: www.fornobravo.com/PDF/residential_install.pdf

Front View

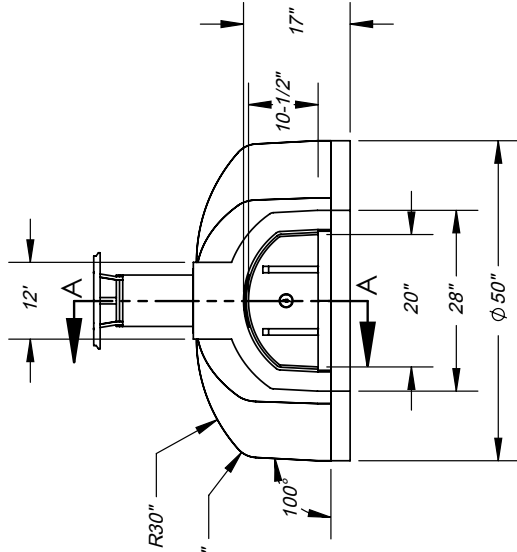

Premio2G 110G Pizza Oven Kit includes:

- Commercial grade refractory oven dome with integral vent
- 3" ceramic fiber insulation board
- 4" ceramic fiber insulation blanket (multiple 1" thick blankets)
- NSF-4 rated fireclay cooking surface
- High temp refractory mortar to seal dome joints
- Single wall stove pipe, anchor plate, 24" pipe and cap
- Double wall insulated steel door
- Door thermometer

Home Gas Features includes:

- Fuel: Wood, liquid propane or natural gas
- Drago P1 Plus burner assembly (specify, natural gas or liquid propane)
- Burner ignition box with four settings (off, pilot, low and high flame)
- Stainless steel ash guard for burner
- Remote thermometer
- Gas leak detector
- Propane Gas valve regulator. *(Note: Natural gas regulator must be supplied by local certified installer.)

Sold separately:

- UL certified spark arrestor
- Decorative brick arch
- Double wall insulated steel door to retain heat longer
- Cucina stand with steel frame and hardie-backer board pre-cut
- Stove pipe extension
- Upgrade to double wall chimney for indoor installations / covered patios
- Pizza Oven Tools, infrared thermometer, gloves and other items

To be provided by customer / contractor:

- Concrete support pad with rebar (or equivalent structure)
- Concrete masonry stand (CMU) or equivalent non-combustible structure
- Decorative facade materials (stucco, brick, tile, steel, etc.)

Certifications:

Tested and compliant with:
 UL737, UL2162, NSF-4, CAN/CGA-1.8 Dual, ANSI-Z83.11 Dual, ANSI-Z221.58-CSA 1.6-2007
 For more information about our certifications, click here: www.fornobravo.com/ul-certified

WARNING:
READ ALL INSTRUCTIONS IN INSTALLATION MANUAL BEFORE INSTALLING AND USING APPLIANCE.
FAILURE TO FOLLOW INSTRUCTIONS MAY RESULT IN PROPERTY DAMAGE, BODILY INJURY OR EVEN DEATH
 Installation manual can be found by clicking on this link: www.fornobravo.com/PDF/residential_install.pdf

Side Elevation

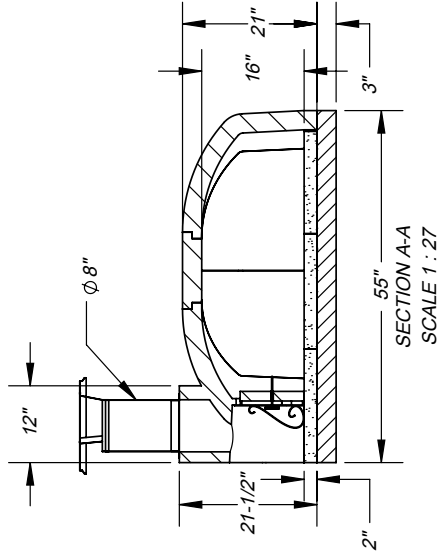

Top View

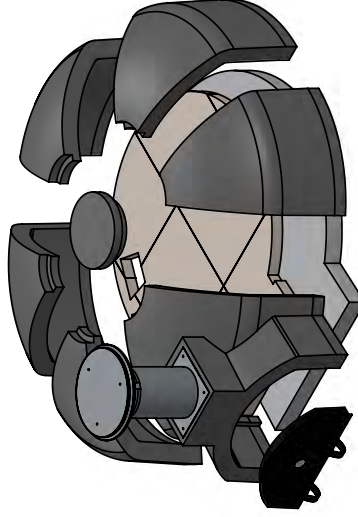
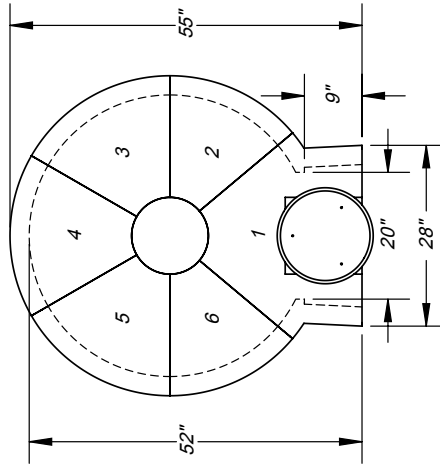

Made in the U.S.A. Residential Gas Fired Pizza Oven

FORNO BRAVO®
 THE WORLD'S FINEST PIZZA OVENS

Premio2G 110G
 Gas Fired Pizza Oven
 Architect Drawings

Revision 6/13/2016 Sheet: 6 of 7



1 2 3 4 5

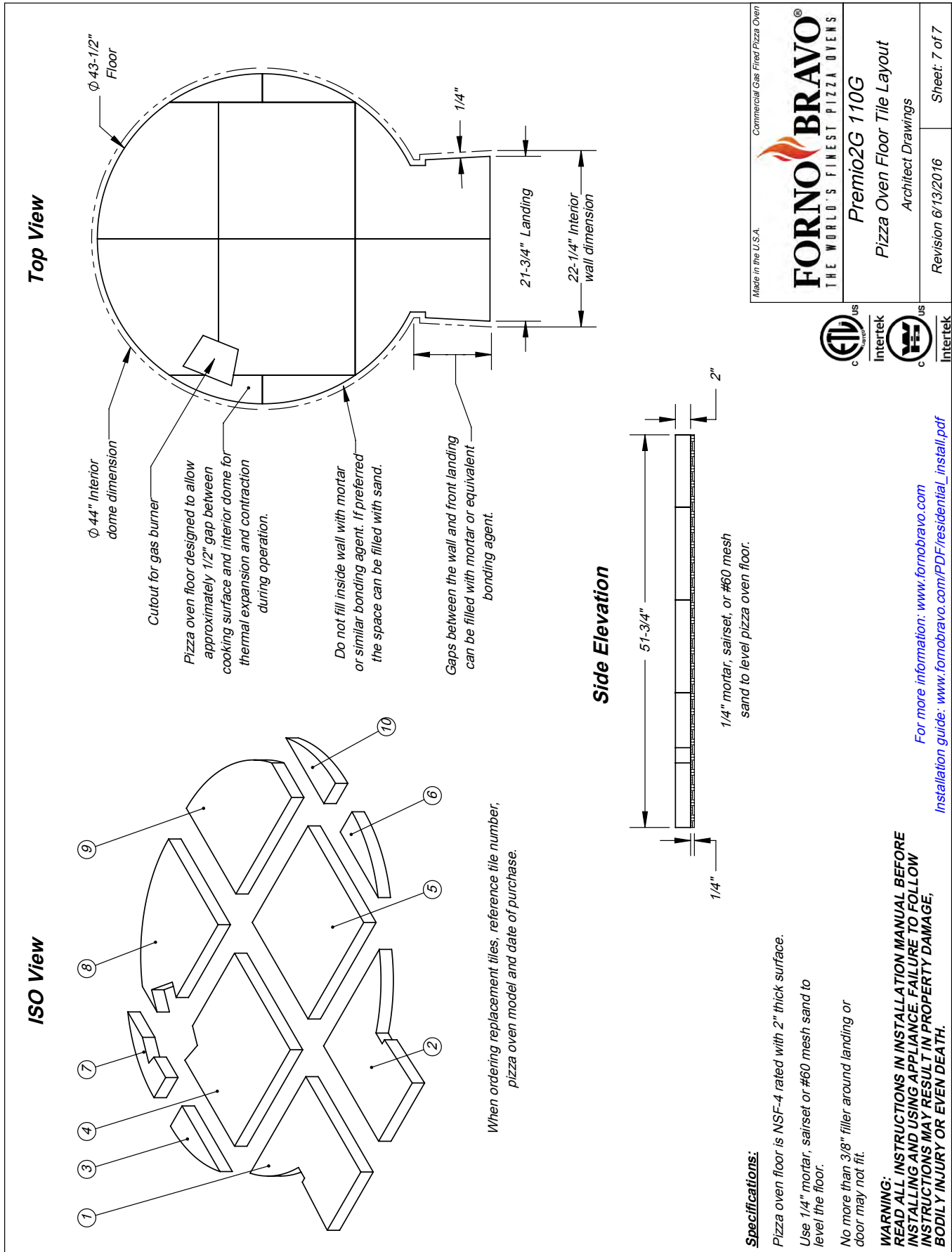

Made in the U.S.A. Commercial Gas Fired Pizza Oven

FORNO BRAVO
 THE WORLD'S FINEST PIZZA OVENS

Premio2G 110G
 Pizza Oven Floor Tile Layout
 Architect Drawings

Revision 6/13/2016 Sheet: 7 of 7



For more information: www.fornobravo.com
 Installation guide: www.fornobravo.com/PDF/residential_install.pdf

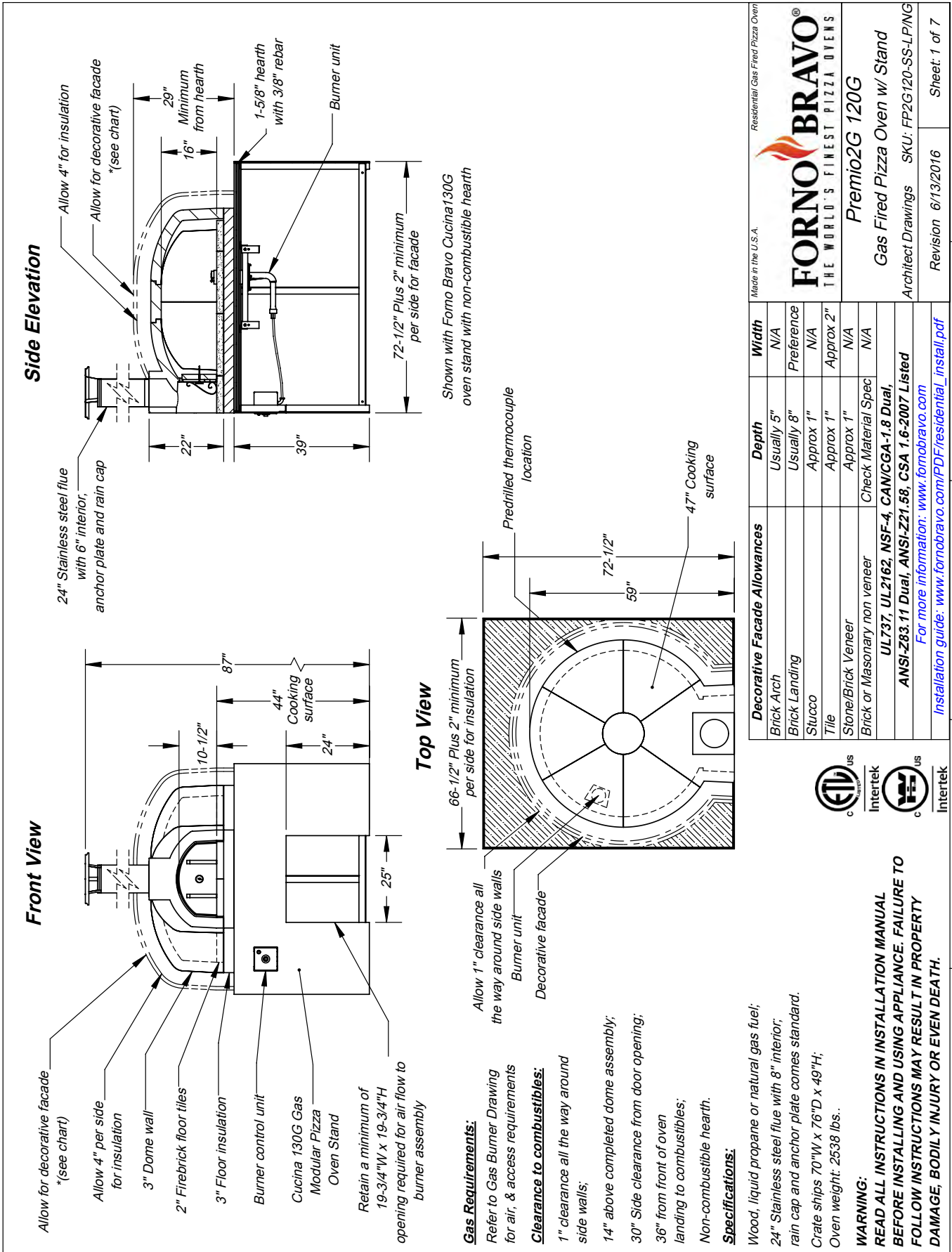

Side Elevation

Front View

Top View

Gas Requirements:

Refer to Gas Burner Drawing for air, & access requirements

Clearance to combustibles:

1" clearance all the way around side walls;

14" above completed dome assembly;

30" Side clearance from door opening;

36" from front of oven landing to combustibles;

Non-combustible hearth.

Specifications:

Wood, liquid propane or natural gas fuel;

24" Stainless steel flue with 8" interior rain cap and anchor plate comes standard.

Crate ships 70"W x 76"D x 49"H;

Oven weight: 2538 lbs..

WARNING:

READ ALL INSTRUCTIONS IN INSTALLATION MANUAL BEFORE INSTALLING AND USING APPLIANCE. FAILURE TO FOLLOW INSTRUCTIONS MAY RESULT IN PROPERTY DAMAGE, BODILY INJURY OR EVEN DEATH.

<p>Made in the U.S.A.</p> <p>Residential Gas Fired Pizza Oven</p> <p>FORNO BRAVO®</p> <p>THE WORLD'S FINEST PIZZA OVENS</p>	
<p>Premio2G 120G</p>	
<p>Gas Fired Pizza Oven w/ Stand</p>	
<p>Architect Drawings SKU: FP2G120-SS-LPING</p>	
<p>Revision 6/13/2016 Sheet: 1 of 7</p>	
Decorative Facade Allowances	Width
Brick Arch	N/A
Brick Landing	Preference
Stucco	N/A
Tile	Approx 2"
Stone/Brick Veneer	N/A
Brick or Masonry non veneer	N/A
<p>Check Material Spec</p> <p>UL737, UL2162, NSF-4, CAN/CGA-1.8 Dual,</p> <p>ANSI-Z83.11 Dual, ANSI-Z21.58, CSA 1.6-2007 Listed</p> <p>For more information: www.fornobravo.com</p> <p>Installation guide: www.fornobravo.com/PDF/residential_install.pdf</p>	
Depth	Depth
Usually 5"	Usually 5"
Usually 8"	Usually 8"
Approx 1"	Approx 1"
Approx 1"	Approx 1"
Approx 1"	Approx 1"

Detailed view of burner placement

SCALE 1:4

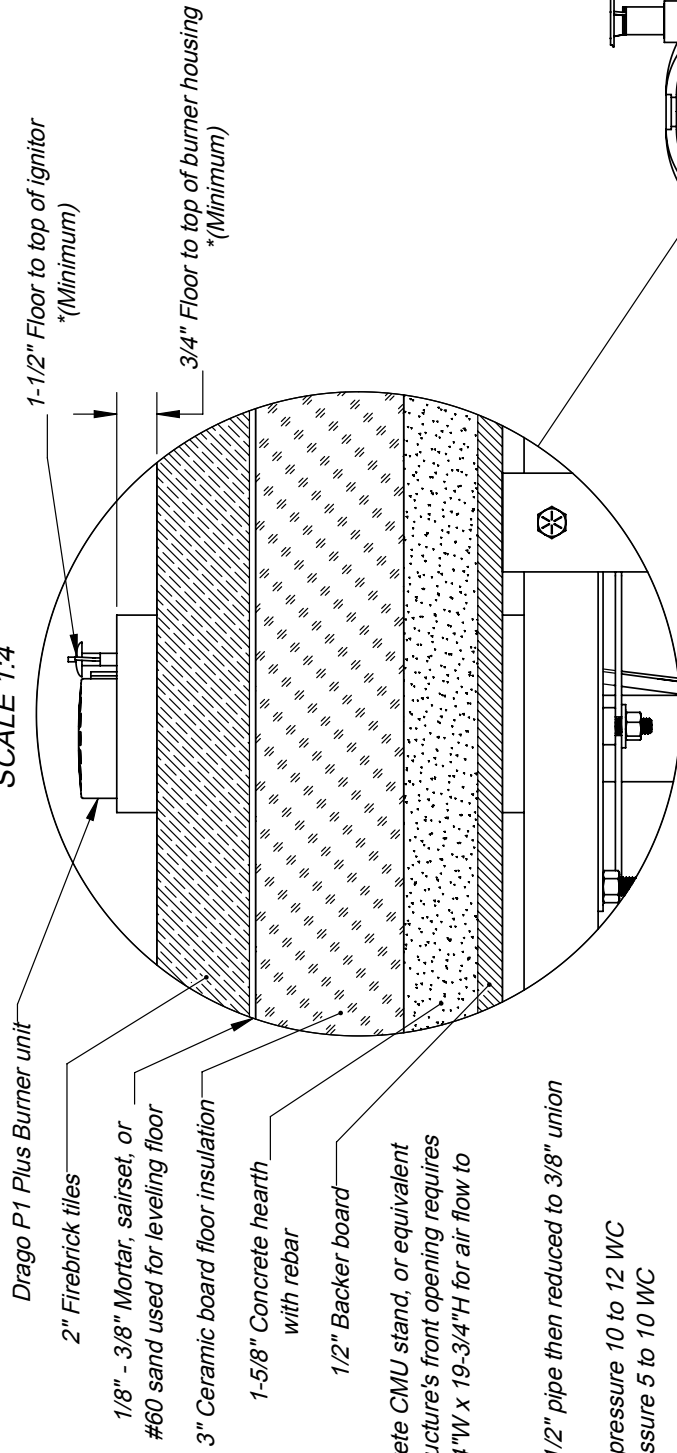

Drago P1 Plus Burner unit

2" Firebrick tiles

1/8" - 3/8" Mortar, sarsset, or #60 sand used for leveling floor

3" Ceramic board floor insulation

1-5/8" Concrete hearth with rebar

1/2" Backer board

Specifications:

Cucina stand, concrete CMU stand, or equivalent non-combustible structure's front opening requires a minimum of 19-3/4"W x 19-3/4"H for air flow to burner assembly

Gas line should be 1/2" pipe then reduced to 3/8" union

Liquid Propane line pressure 10 to 12 WC

Natural Gas line pressure 5 to 10 WC

Factory settings:

Natural Gas - 2.75 orifice, air shutter at #2 position

Liquid Propane - 2.25 orifice, air shutter at #3 position

WARNING: DO NOT CHANGE FACTORY SETTINGS WITHOUT CONSULTING MANUFACTURER OR CERTIFIED TECHNICIAN.

WARNING: READ ALL INSTRUCTIONS IN INSTALLATION MANUAL BEFORE INSTALLING AND USING APPLIANCE. FAILURE TO FOLLOW INSTRUCTIONS MAY RESULT IN PROPERTY DAMAGE, BODILY INJURY OR EVEN DEATH.

UL approved settings for gas orifices		NG	LP
Input rate w/ 2.5 orifice and air shutter at #2 setting (Btu/hr)		32000	
Input rate w/ 2.7 orifice and air shutter at #2 setting (Btu/hr)		38000	
Input rate w/ 1.75 orifice and air shutter at #3 setting (Btu/hr)			32000
Input rate w/ 2.0 orifice and air shutter at #3 setting (Btu/hr)			43000
Input rate w/ 2.25 orifice and air shutter at #3 setting (Btu/hr)			51000
Input rate w/ 2.5 orifice and air shutter at #4 setting (Btu/hr)			46000
For more information: www.fornobravo.com			
Installation guide: www.fornobravo.com/PDF/residential_install.pdf			

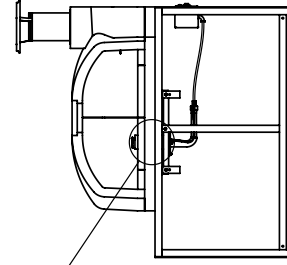

Forno Bravo Premio2G 120G Pizza Oven and Cucina 130G Modular Pizza Oven Stand

Made in the U.S.A. Residential Gas Fired Pizza Oven

FORNO BRAVO®
THE WORLD'S FINEST PIZZA OVENS

Premio2G 120G
Gas Burner Detailed View
Architect Drawings

Revision 6/13/2016 Sheet: 2 of 7



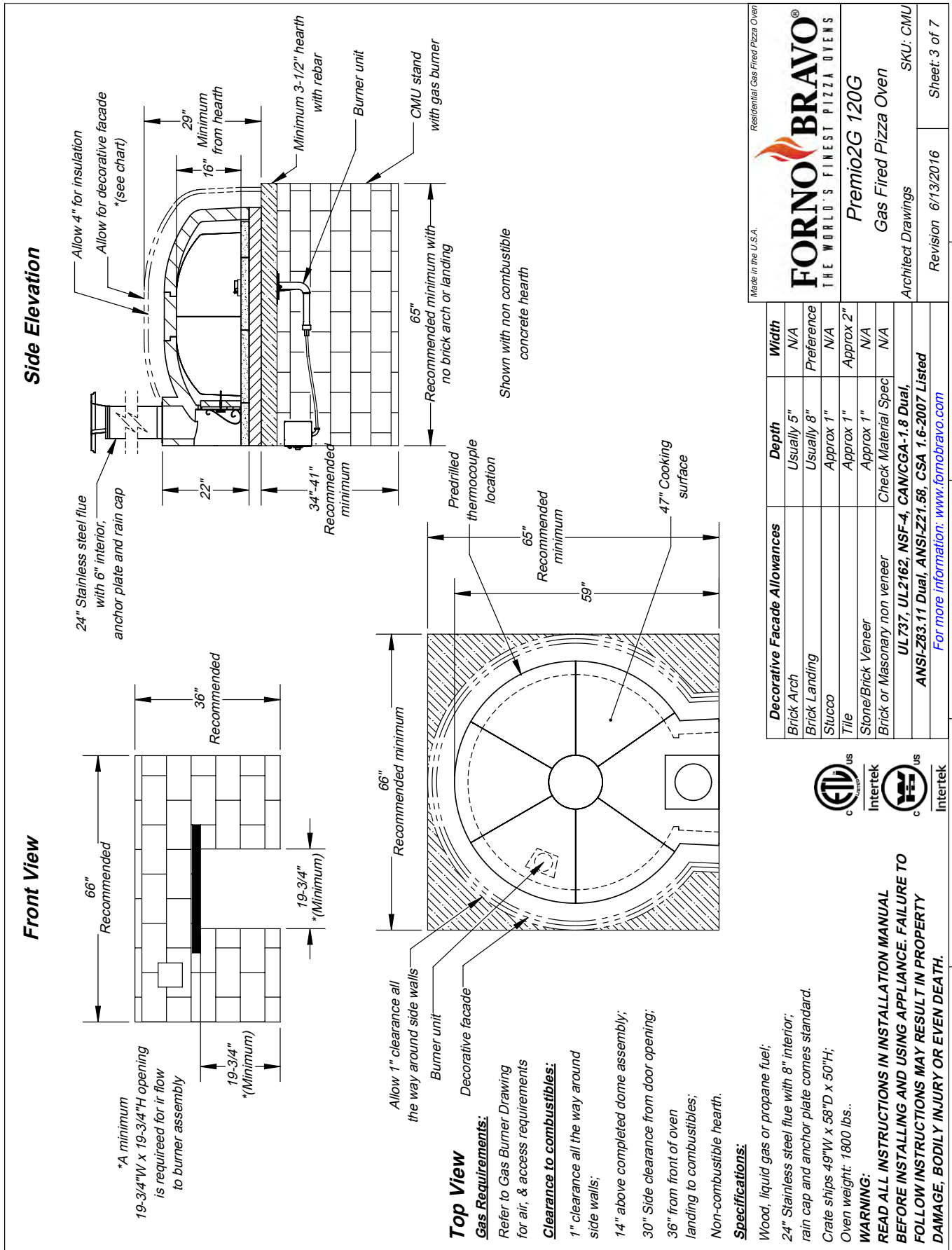

Made in the U.S.A. Residential Gas Fired Pizza Oven

FORNO BRAVO®
THE WORLD'S FINEST PIZZA OVENS

Premio2G 120G
Gas Fired Pizza Oven

Architect Drawings
Revision 6/13/2016
SKU: CMU
Sheet: 3 of 7

Decorative Facade Allowances	Depth	Width
Brick Arch	Usually 5"	N/A
Brick Landing	Usually 8"	Preference
Stucco	Approx 1"	N/A
Tile	Approx 1"	Approx 2"
Stone/Brick Veneer	Approx 1"	N/A
Brick or Masonry non veneer	Check Material Spec	N/A
UL737, UL2162, NSF-4, CAN/CGA-1.8 Dual, ANSI-Z83.11 Dual, ANSI-Z21.58, CSA 1.6-2007 Listed		
For more information: www.fornobravo.com		



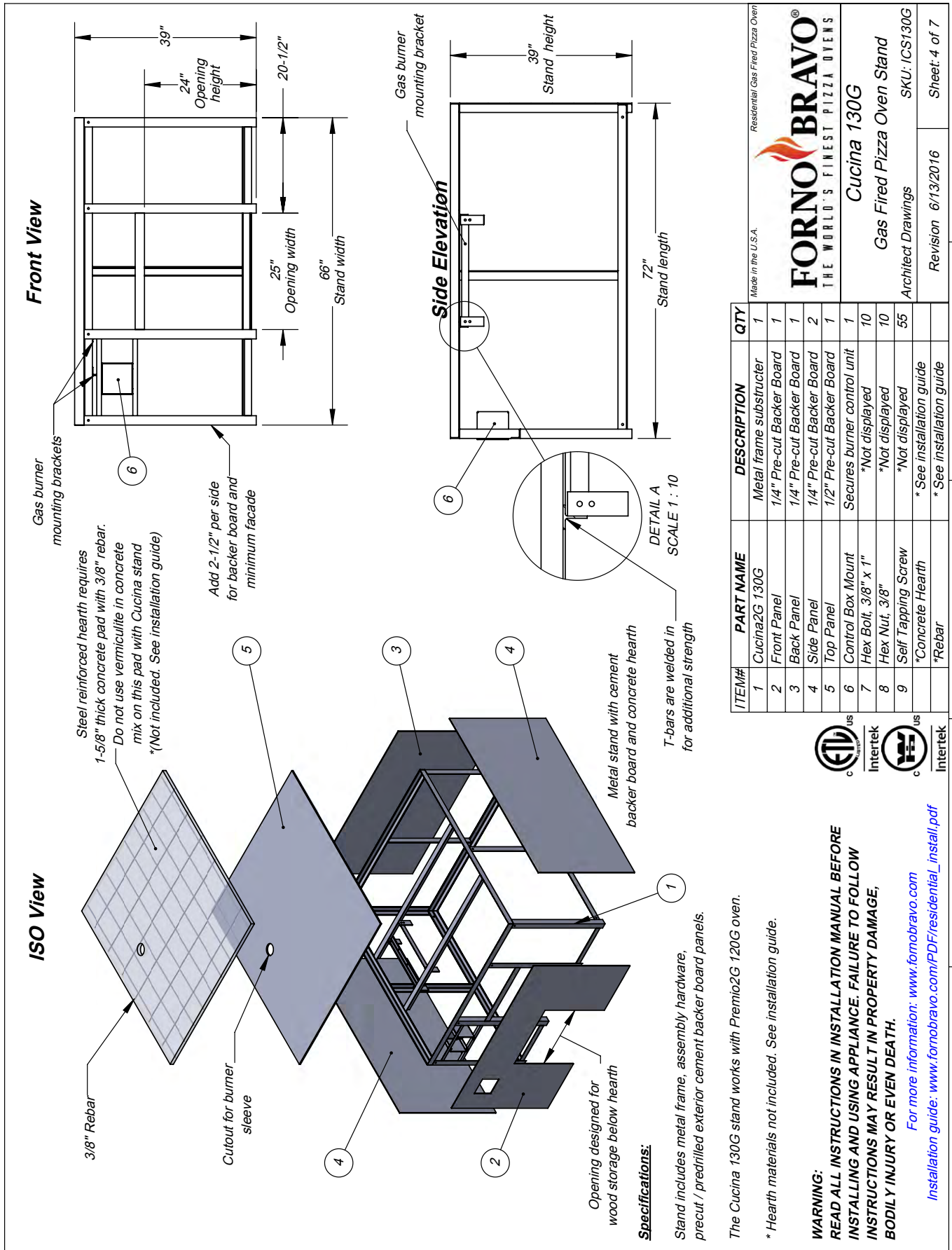

ITEM#	PART NAME	DESCRIPTION	QTY
1	Cucina2G 130G	Metal frame substructure	1
2	Front Panel	1/4" Pre-cut Backer Board	1
3	Back Panel	1/4" Pre-cut Backer Board	1
4	Side Panel	1/4" Pre-cut Backer Board	2
5	Top Panel	1/2" Pre-cut Backer Board	1
6	Control Box Mount	Secures burner control unit	1
7	Hex Bolt, 3/8" x 1"	*Not displayed	10
8	Hex Nut, 3/8"	*Not displayed	10
9	Self Tapping Screw	*Not displayed	55
	*Concrete Hearth	* See installation guide	
	*Rebar	* See installation guide	

Made in the U.S.A.
Residential Gas Fired Pizza Oven

FORNO BRAVO®
THE WORLD'S FINEST PIZZA OVENS

Cucina 130G

Gas Fired Pizza Oven Stand

Architect Drawings SKU: ICS130G

Revision 6/13/2016 Sheet: 4 of 7



WARNING:
READ ALL INSTRUCTIONS IN INSTALLATION MANUAL BEFORE INSTALLING AND USING APPLIANCE. FAILURE TO FOLLOW INSTRUCTIONS MAY RESULT IN PROPERTY DAMAGE, BODILY INJURY OR EVEN DEATH.

For more information: www.fornobravo.com
Installation guide: www.fornobravo.com/PDF/residential_install.pdf

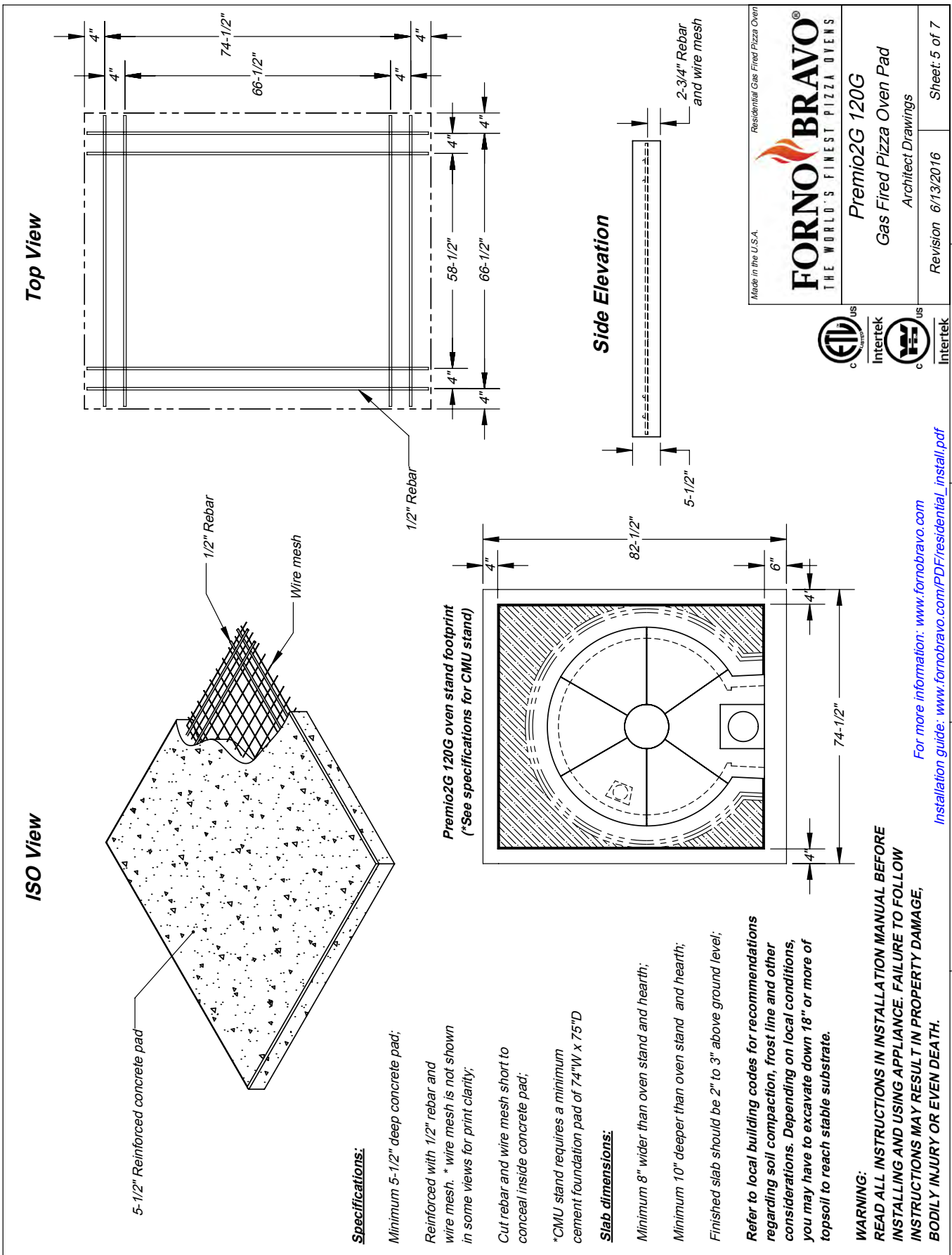

Top View

Side Elevation

ISO View

5-1/2" Reinforced concrete pad

1/2" Rebar
Wire mesh

Specifications:

Minimum 5-1/2" deep concrete pad;

Reinforced with 1/2" rebar and wire mesh. * wire mesh is not shown in some views for print clarity;

Cut rebar and wire mesh short to conceal inside concrete pad;

*CMU stand requires a minimum cement foundation pad of 74"W x 75"D

Slab dimensions:

Minimum 8" wider than oven stand and hearth;

Minimum 10" deeper than oven stand and hearth;

Finished slab should be 2" to 3" above ground level;

Refer to local building codes for recommendations regarding soil compaction, frost line and other considerations. Depending on local conditions, you may have to excavate down 18" or more of topsoil to reach stable substrate.

**WARNING:
READ ALL INSTRUCTIONS IN INSTALLATION MANUAL BEFORE INSTALLING AND USING APPLIANCE. FAILURE TO FOLLOW INSTRUCTIONS MAY RESULT IN PROPERTY DAMAGE, BODILY INJURY OR EVEN DEATH.**

Premio2G 120G oven stand footprint
(*See specifications for CMU stand)

Made in the U.S.A. Residential Gas Fired Pizza Oven

FORNO BRAVO®
THE WORLD'S FINEST PIZZA OVENS

Premio2G 120G
Gas Fired Pizza Oven Pad
Architect Drawings

Revision 6/13/2016 Sheet: 5 of 7



For more information: www.fornobravo.com
Installation guide: www.fornobravo.com/PDF/residential_install.pdf

Front View

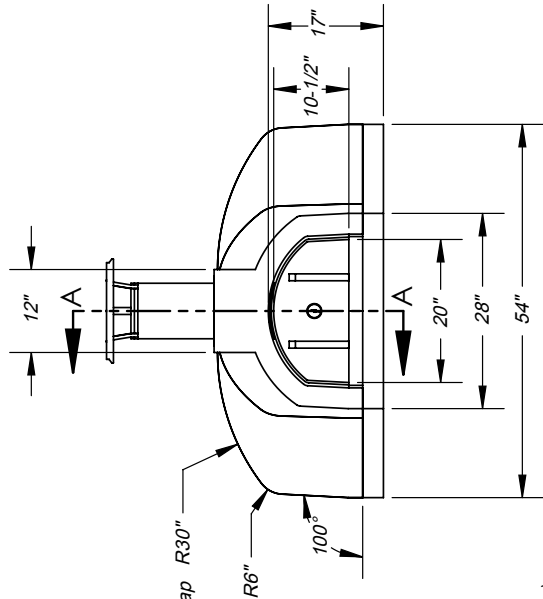

Side Elevation

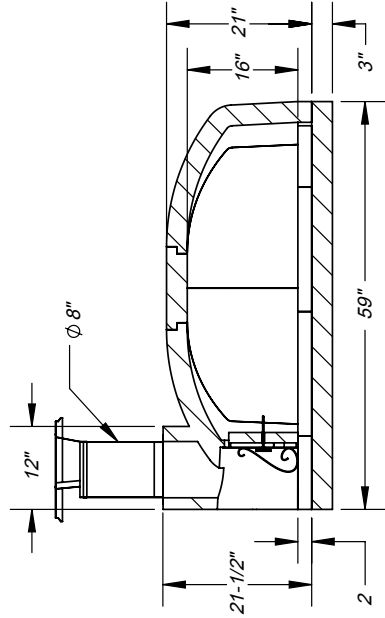

SECTION A-A
SCALE 1 : 25

Top View

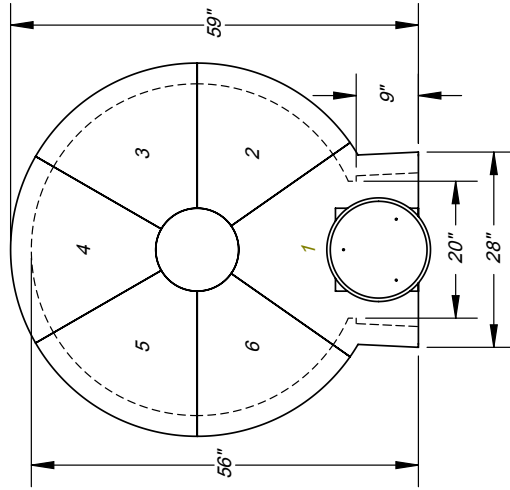

Premio2G 120G Pizza Oven Kit includes:

- Commercial grade refractory oven dome with integral vent
- 3" ceramic fiber insulation board
- 4" ceramic fiber insulation blanket (multiple 1" thick blankets)
- NSF-4 rated fireclay cooking surface
- High temp refractory mortar to seal dome joints
- Single wall stove pipe, anchor plate, 24" pipe and cap
- Double wall insulated steel door
- Door thermometer

Home Gas Features includes:

- Fuel: Wood, liquid propane or natural gas
- Drago P1 Plus burner assembly (specify, natural gas or liquid propane)
- Burner ignition box with four settings (off, pilot, low and high flame)
- Stainless steel ash guard for burner
- Remote thermometer
- Gas leak detector
- Propane Gas valve regulator. *(Note: Natural gas regulator must be supplied by local certified installer.)

Sold separately:

- UL certified spark arrestor
- Decorative brick arch
- Double wall insulated steel door to retain heat longer
- Cucina stand with steel frame and hardie-backer board pre-cut
- Stove pipe extension
- Upgrade to double wall chimney for indoor installations / covered patios
- Pizza Oven Tools, infrared thermometer, gloves and other items

To be provided by customer / contractor:

- Concrete support pad with rebar (or equivalent structure)
- Concrete masonry stand (CMU) or equivalent non-combustible structure
- Decorative facade materials (stucco, brick, tile, steel, etc.)

Certifications:

Tested and compliant with:
 UL737, UL2162, NSF-4, CAN/CGA-1.8 Dual, ANSI-Z83.11 Dual, ANSI-Z21.58-CSA 1.6-2007
 For more information about our certifications, click here: www.fornobravo.com/ul-certified

WARNING:
READ ALL INSTRUCTIONS IN INSTALLATION MANUAL BEFORE INSTALLING AND USING APPLIANCE.
FAILURE TO FOLLOW INSTRUCTIONS MAY RESULT IN PROPERTY DAMAGE, BODILY INJURY OR EVEN DEATH
 Installation manual can be found by clicking on this link: www.fornobravo.com/PDF/residential_install.pdf

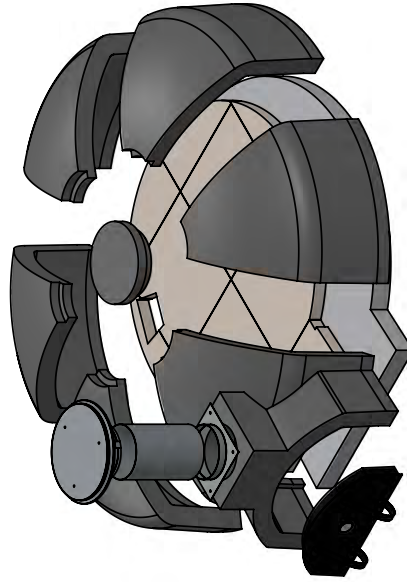

Made in the U.S.A.

Residential Gas Fired Pizza Oven



FORNO BRAVO®
 THE WORLD'S FINEST PIZZA OVENS

Premio2G 120G
 Gas Fired Pizza Oven
 Architect Drawings
 Revision 6/13/2016 Sheet: 6 of 7



1 2 3 4 5

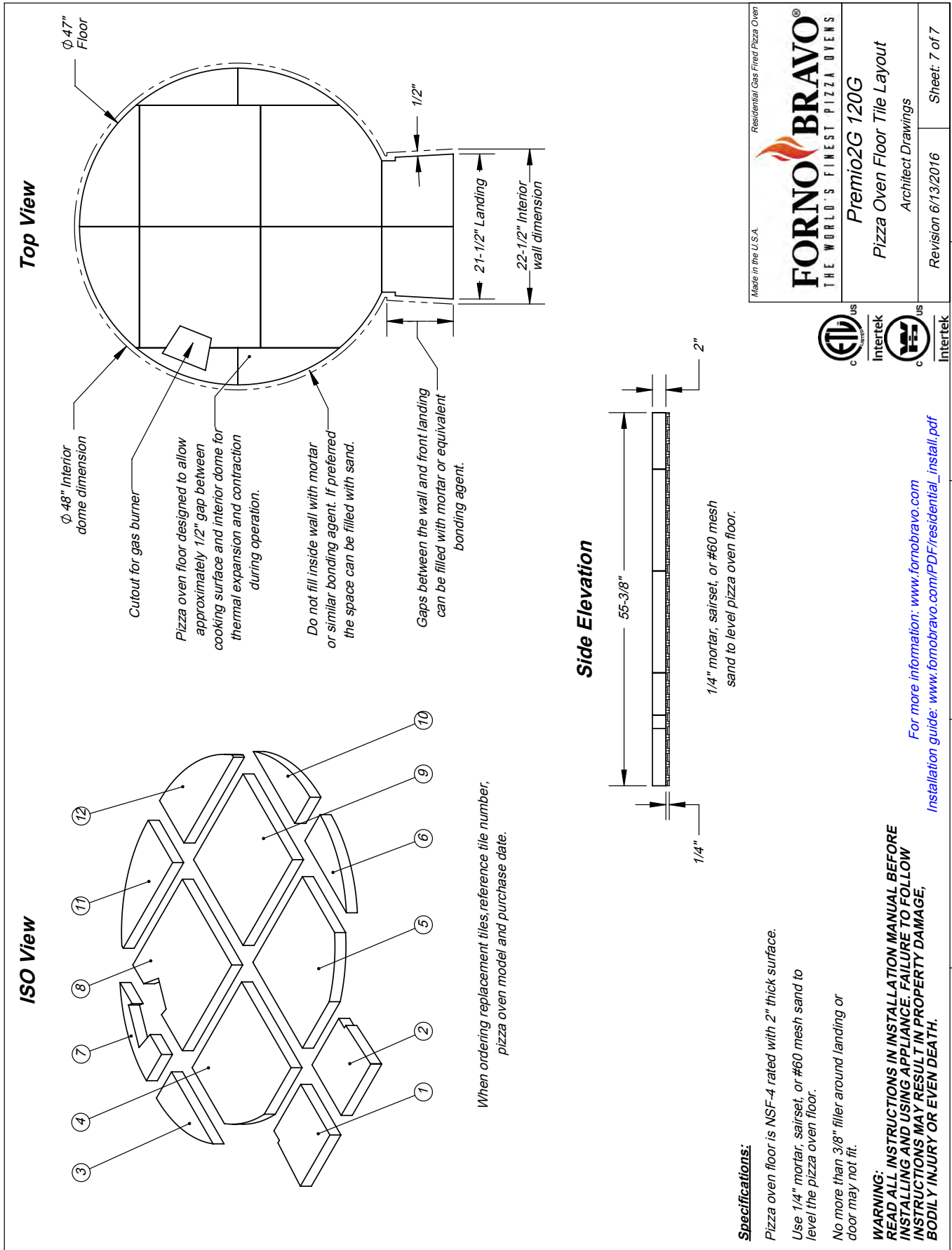

Casa2G and Premio2G

Limited Warranty

Forno Bravo, LLC Ovens and Fireplaces

THE WARRANTY

Forno Bravo, LLC, a producer and importer of quality ovens and fireplaces, warrants its refractory ovens and fireplaces (herein referred to as Product) to be free from defects in materials and workmanship on the major structural Product component (dome, firebox), for a period of five (5) years from the date of shipment. Warranty may be invalidated if Product is not correctly installed, cured, operated, and maintained according to all supplied instructions.

Forno Bravo, LLC warrants its Products' support components (floor, venting system, gas burner components, factory-installed finishes, stand, door, and accessories) to be free from defects in materials and workmanship for a period of one (1) year from the date of shipment.

QUALIFICATIONS TO THE WARRANTY

The complete Product Warranty outlined above does not apply under the following circumstances:

- (1) The Product was not installed in accordance with Forno Bravo installation instructions and local building codes.
- (2) This Warranty does not apply to any hairline cracking caused by over-firing or the failure to follow a proper curing schedule. See Product Manual for a detailed explanation of this curing schedule.
- (3) The Product has been subjected to non-standard use, including but not limited to, tossing or throwing firewood into the oven with force, addition of non-approved appliances or burners, burning fuels with abnormal burning characteristics, including: driftwood, coal, plywood, and wood products using a binder that may burn at excessive temperatures, causing damage to the Product.
- (4) The Product has been subjected to icing or wet-mopping the oven while it is still heated (which can cause damage/cracking to the oven floor.) Improper chemicals or liquids have been used to clean or sanitize the interior of the oven.
- (5) This Warranty does not cover damage caused by storing any materials on the top of a fully assembled oven or on the dome of an unfinished kit oven.
- (6) This Warranty does not apply to normal wear and tear of the Product, or on parts that

would be worn or replaced under normal conditions, including:

- (a) Normal, minor cracking due to expansion and contraction stress relief in the refractory materials of either the dome or floor tiles.
- (b) Discoloration of exterior finishes in areas repeatedly exposed to smoke, as this is considered normal wear on wood fired pizza ovens and fireplaces.
- (7) This Warranty does not cover damage to, or failure of the Product, resulting from natural or other catastrophes, such as flood, fire, wind, or storm.
- (8) In the event that the UL Listing Plate (if applicable) has been removed, altered, or obliterated.

LIMITATION ON LIABILITY

It is expressly agreed and understood that Forno Bravo's sole obligation, and Purchaser's exclusive remedy under this Warranty, and under any other Warranty, expressed or implied otherwise, shall be limited to replacement, repair, or refund up to the original purchase price of the Product, excluding shipping costs, as specified above. Such liability shall not include, and Purchaser or other third parties, specifically renounces any rights to recover special, incidental, consequential, or other damages of any kind whatsoever, including, but not limited to, injuries to persons or damage to property, loss of profits or anticipated profits, damage to business reputation or goodwill, all costs incurred receiving, unloading, moving at your location, and installing Forno Bravo Products, or loss of use of the Product.

In no event shall Forno Bravo be responsible for any incidental or consequential damages caused by defects in its Products, whether such damage occurs, or is discovered before or after replacement or repair, and whether or not such damage is caused by Forno Bravo. The duration of any Warranty with respect to this Product is limited to legitimate claims received within the duration of the foregoing Warranty.

Warranty of replacement parts or Product shall only be from the original purchase date of Product, not the date of repair or replacement covered under this Warranty. Parts to be replaced under the Warranty will be repaired or replaced with new or functionally sound parts at Forno Bravo's option.

Note: Some states do not allow the exclusion or limitation of incidental or consequential

damages, or the duration of an implied warranty, so the above exclusion or limitations may not apply to you.

INVESTIGATION OF CLAIMS AGAINST WARRANTY

Forno Bravo reserves the right to investigate any and all claims against this Warranty and to decide upon method of settlement.

Before any Product is returned, Forno Bravo, or its authorized representative, must provide Purchaser with written return authorization and instructions for preparation of the shipment. Failure to properly package Product for return may result in Purchaser being billed by Forno Bravo. Forno Bravo reserves the right to bill Purchaser for return freight if Product was found to be damaged through negligence or Warranty was voided, as outlined in this Warranty. Reference your original Terms of Sale Agreement for additional details.

DEALERS HAVE NO AUTHORITY TO ALTER THIS WARRANTY

Forno Bravo's employees and dealers have no authority to make any Warranties, nor to authorize any remedies in addition to, or inconsistent with, those stated above.

HOW TO REGISTER A CLAIM AGAINST WARRANTY

In order for any claim under this Warranty to be valid, Forno Bravo must be notified of the claimed defect by either:

- Telephone at 1-800-407-5119, or outside the U.S. at +1 (408) 317-0124,
- Writing to Forno Bravo, 13525 Blackie Road, Castroville, CA 95012, or
- Please fill out our easy-to-use [technical support form](#) for claims against the warranty.

All claims against this Warranty should include the Product model, original invoice number, date of installation, a description of the defect, photographs of the area of concern, and a full description of the circumstances giving rise to the Warranty Claim, if known. Please examine all of the contents of your delivery as soon as possible after receipt and inform Forno Bravo within ten (10) days if any items are missing, incorrect, or damaged.

Updated 4/5/21